

ULTRA U626 'TROUBADOR'

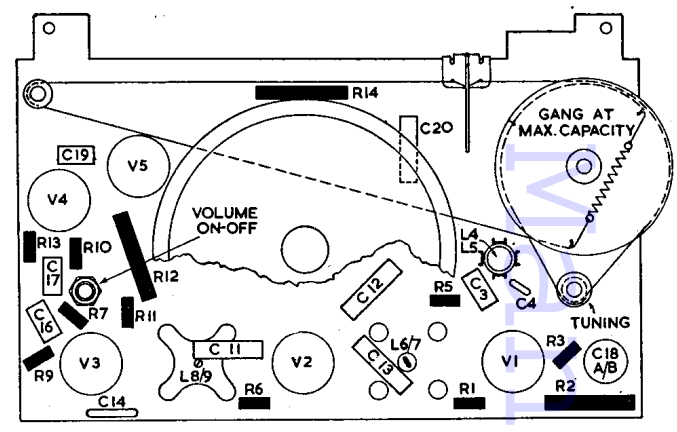

| | | | | | | | | |
|---|------|----|-----|----|-----|---|---|-----|
| R | 13 | 10 | 12 | 6 | 14 | 5 | 3 | 2 |
| C | 16/7 | 19 | 14 | 11 | 20 | 3 | 4 | 18 |
| L | | | 8,9 | | 6,7 | | | 4,5 |

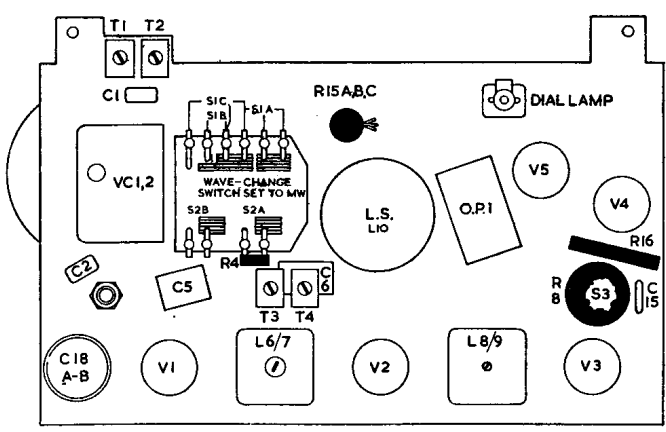
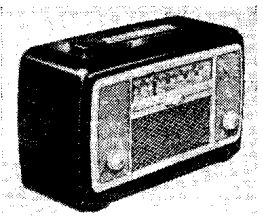
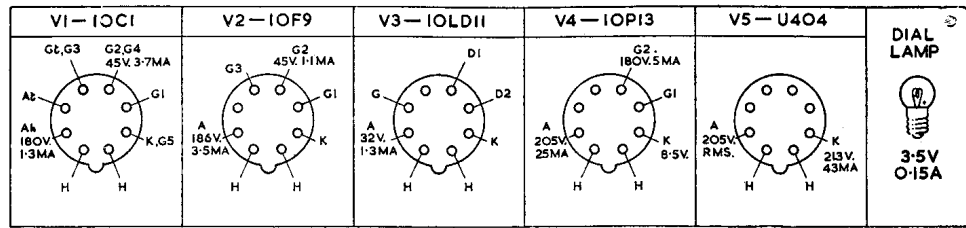

Transportable table radio receiver for 200-250V AC-DC supplies. Two-waveband, five-valve superhet with internal frame aerial. Moulded plastic two-colour cabinet with carrying handle. Made by Ultra Electric, Ltd., Western Avenue, Acton, London, W3.

INDUCTORS

| L | Ohms |
|-------|----------------------|
| 1 | 1.4 |
| 2 | 1.2 |
| 3 | 1.7 |
| 4 | 3 |
| 5 | 3 |
| 6 | 8.5 |
| 7 | 8.5 |
| 8 | 9.5 |
| 9 | 9.5 |
| 10 | 2.6 |
| 10 | LS Speech Coil |
| O.P.1 | Primary |
| 11 | 0.05 Tubular 350V |
| 12 | 0.05 Tubular 350V |
| 13 | 0.05 Tubular 350V |
| 14 | 200pF Silver Mica |
| 15 | 100pF Silver Mica |
| 16 | 0.01 Tubular 500V |
| 17 | 0.01 Tubular 500V |
| 18A | 16 Electrolytic 350V |
| 18B | 24 Electrolytic 350V |
| 19 | 0.01 Tubular 500V |
| 20 | 0.01 Tubular 1,000V |

CAPACITORS

| C | mF | Type |
|-----|--------|-------------------|
| 1 | 170pF | Silver Mica |
| 2 | 390pF | Silver Mica |
| 3 | 120pF | Silver Mica |
| 4 | 120pF | Silver Mica |
| 5 | 570pF | Silver Mica |
| 6 | 520pF | Silver Mica |
| 7 | 120pF | Silver Mica |
| 8 | 120pF | Silver Mica |
| 9 | 100pF | Silver Mica |
| 10 | 100pF | Silver Mica |
| 11 | 0.05 | Tubular 350V |
| 12 | 0.05 | Tubular 350V |
| 13 | 0.05 | Tubular 350V |
| 14 | 200pF | Silver Mica |
| 15 | 100pF | Silver Mica |
| 16 | 0.01 | Tubular 500V |
| 17 | 0.01 | Tubular 500V |
| 18A | 16 | Electrolytic 350V |
| 18B | 24 | Electrolytic 350V |
| 19 | 0.01 | Tubular 500V |
| 20 | 0.01 | Tubular 1,000V |
| VC1 | 3-55pF | Trimmers |
| VC2 | 528pF | Swing |

RESISTORS

| R | Ohms | Watts |
|-----|------|------------------------|
| 1 | 470K | 1/2 |
| 2 | 27K | 1/2 |
| 3 | 47K | 1/2 |
| 4 | 1.8K | 1/2 |
| 5 | 68K | 1/2 |
| 6 | 1M | 1/2 |
| 7 | 100K | 1/2 |
| 8 | 1M | potr. with d.p. switch |
| 9 | 4.7M | 1/2 |
| 10 | 330K | 1/2 |
| 11 | 100K | 1/2 |
| 12 | 1.8K | 1/2 |
| 13 | 300 | 1/2 |
| 14 | 120 | 1/2 |
| 15A | 700 | 1/2 |
| B | 120 | 10 |
| C | 90 | 10 |
| 16 | 39 | 1 |

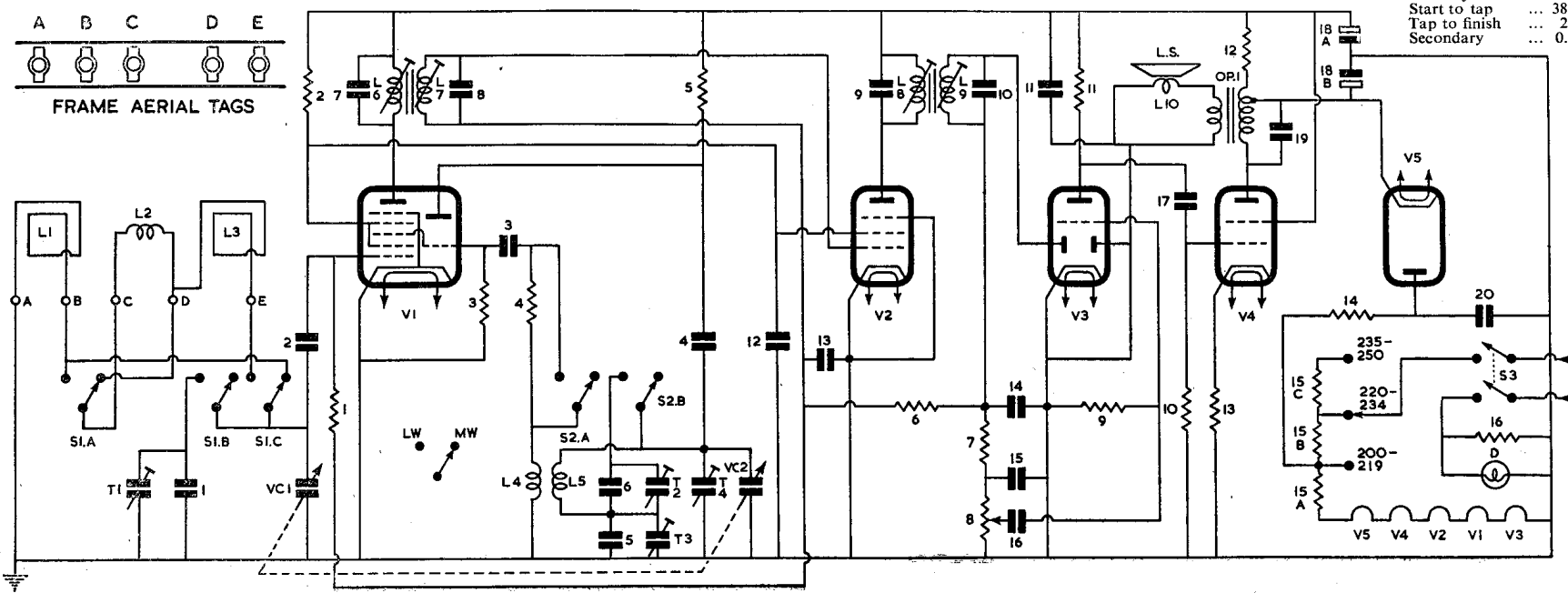

Continued on page 32

STRAD; MODEL 501

Continued from page 30

AERIAL signal is fed through an IF filter consisting of L1, C1 to S1 and thence switched to aerial coupling coils L2 (SW), L4 (MW, LW). The grid coils L3 (SW), L5 (MW), L6 (LW) which are trimmed by T1, T2, T3 respectively, are switched by S2 to aerial tuning capacitor VC1 and coupled direct to V1.

AVC voltages decoupled by R7, C2 are fed through the tuned coils to V1 on all wavebands. Cathode bias is provided by R1, decoupled by C4. Screen voltage is obtained from R5 and decoupled by C3. Primary L11, C9 of IFT1 is in the heptode anode circuit of V1.

Oscillator is connected in a tuned anode shunt fed circuit. The anode coils L8 (SW), L9 (MW), L10 (LW), which are trimmed by T4, T5, T6, C6 and padded by C5, T7, T8 are switched by S4 to oscillator tuning capacitor VC2 and coupled by C7 to oscillator anode of V1 of which R3 is the load resistor. Grid reaction voltages which are obtained inductively from L7 (SW), and capacitively from padders T7, T8 on MW and LW bands, are switched by S3 to oscillator grid of V1. R2 is grid leak and R4 a SW limiter resistor.

IF amplifier operates at 465kc/s. Secondary L12, C10 of IFT1 feeds signal and approximately half of AVC voltage decoupled by R6, C8 to IF amplifier V2. Cathode and suppressor of V2 are connected down to chassis. Screen voltage is obtained from R5 decoupled by C3. Primary L13, C11 of IFT2 are in the anode circuit.

Signal rectifier. Secondary L14, C12 of IFT2 feeds signal to one of the diodes of V3. Diode load is formed by R10, R12 and R8, C13, C15 give IF filtering.

AVC. The DC component of the rectified signal is used for this purpose. Full AVC decoupled by R7, C2 is fed to V1, whilst approximately half the available voltage which is obtained from junction of R10, R12 and decoupled by R6, C8 is fed to V2. The second diode of V3 is not used and is connected down to chassis.

Pickup. Sockets are fitted at rear of chassis for connection of the pickup of the gramophone unit. Pickup signal is fed to S5 which in its Gram position switches signal to volume control R9.

AF amplifier. Rectified signal is fed by C14 to S5 which in its three radio positions passes signal on to volume control R9 and thence to grid of triode section of V3. Cathode bias is provided by R13 decoupled by C16. R11 is the anode load.

Output stage. C17 feeds signal from anode of V3 to beam tetrode output valve V4. Cathode bias is provided by R17 decoupled by C20. Screen voltage is obtained direct from HT line to V1 to V3 and is decoupled by C18. Primary L15 of output transformer OPI is in the anode circuit.

Variable top cut tone control is given by R15, C19 which in effect is shunted across L15. Secondary L16 feeds output to an 8in. PM speaker L17. Sockets are fitted on L16 for connection of a low-impedance extension speaker.

The characteristics or connections of an obsolete or foreign valve? The intermediate frequency of a receiver? A public-address problem? The rewinding of a vacuum cleaner motor? Advice on all such problems are available to ELECTRICAL AND RADIO TRADING subscribers on application to the Advice Bureau.

HT is provided by an indirectly heated fullwave rectifier V5. Its anode voltages are obtained from HT secondary L19 of mains input transformer MT1 and heater current from L18. Resistance-capacity smoothing is given by R16, R18, C18, C21, C22. Reservoir capacitor C22 should have a ripple current rating of at least 80mA.

Heaters of V1 to V4 obtain their current from a 4V tapping on L20.

Dial lights are connected across full secondary winding L20, which gives approximately 5V. Primary L21 of MT1 is tapped for inputs of 200-210, 220-230, 240-250V 40-100c/s. S6 which is ganged to the volume control spindle is the ON/OFF switch.

Chassis. Remove the four push-on type control knobs. Undo tone control locking nut and withdraw tone control from front panel. Remove LS plug from socket on receiver chassis and undo and remove the four chassis bolts—chassis can now be withdrawn from cabinet.

TRIMMING INSTRUCTIONS

| Apply signal as stated below | Tune Receiver to | Trim in Order stated for Max. Output |
|--|--|--|
| (1) Remove grid lead to top cap of V1 and connect 500K resistor between top cap and chassis. Short circuit VC2 switch receiver to MW range | — | — |
| (2) 465 Kc/s to gl of V1 via .01 mF | — | Cores of L11, L12, L13, L14, or trimmers if IFT'S are capacity tuned iron cored type |
| (3) 465 kc/s to AE sockets via dummy aerial | Removes/c on VC2 and resistor and replace TC of V1 | Core L1 for minimum |
| (4) With VC1, VC2 fully meshed adjust pointer along drive cord so that it coincides with "set pointer" calibration mark at top right of dial plate | — | — |
| (5) 600 kc/s to AE socket via dummy aerial | 500 m | T7 |
| (6) 1.2 mc/s as above ... | 250 m | T5, T2. Repeat (5), (6). |
| (7) 150 kc/s as above ... | 2,000 m | T8 |
| (8) 300 kc/s as above ... | 1,000 m | T6, T3. Repeat (7), (8) |
| (9) 6 mc/s as above ... | 50 m | Core L8, L3 |
| (10) 15 mc/s as above... | 20 m | T4, T1. Repeat (9), (10) |

ULTRA TROUBADOR

Continued from page 31

AERIAL. Signals are developed in the MW frame aerial winding L1 and additionally in the LW frame L3, when switched into circuit with L1, by S1A and S1C.

A series loading coil L2 is included on LW and short-circuited by S1A on MW. S1B brings into circuit LW aerial trimmer T1 and shunting capacitor C1, the aerial tuning capacitor VC1 remaining connected on both wavebands.

RF signals are coupled by AVC by-pass capacitor C2 to heptode grid of the frequency-changer V1, whose oscillator is connected in a tuned-anode shunt-fed circuit.

Oscillator. The same oscillator coil L4, L5, is used for both medium and long wavebands, a shunt capacitor C6 being switched into circuit on LW by S2B. Amplitude limiting resistor R4, necessary on MW, is shorted by S2A on LW.

IF Amplifier operates at 465kc/s and, via R6, obtains AVC voltage from the signal diode of V3.

AF Amplifier. The rectified audio signal, filtered of IF by C14, R7 and C15, appears across volume control R8, which also functions as diode load. AF voltages are coupled by DC isolating capacitor C16 to the triode grid of V3.

Output stage. C17 couples the signal from the anode of V3 to the grid of beam-tetrode V4. Bias for this stage is provided by cathode resistor R13 which, in the absence of a decoupling capacitor, provides a measure of current feedback.

The anode circuit contains the tapped primary of output transformer OPI. The larger winding functions normally and is shunted by C19 for tonal correction, the secondary being coupled to 5in. PM speaker L10.

MARCONIPHONE T11DA

A MARCONIPHONE T11DA receiver was handed in with the complaint that it "whistled on the stations," especially the Light programme. I suspected the oscillator section and after a look at the circuit diagram decided that if the grid leak (R4 on Marconiphone diagram) had gone high, excessive oscillator voltage would be developed. This proved to be the case—the suspected resistor had risen from its rated one megohm to some four megohms. With that smug feeling that comes when one's applied theory has proved correct, I replaced the resistor with one of the correct value.

My satisfaction was short lived, for as soon as the set had warmed up the whistles appeared again. Had the new resistor gone "high" already? A quick check proved it to be OK. The oscillator circuit was now operating correctly, therefore the next suspect was the grid stopper (R16) on the IF amplifier. Had this by some coincidence gone "low"?

Sure enough, on test this proved to have dropped in value from its rated 10k to 5k. I changed the resistor and, with less assurance this time, I switched on to test but all was well.

Surely a curious coincidence that these two faults, either of which by itself would produce the symptoms should happen together? Strange too that neither resistor broke down completely and that they went in the necessary opposite directions to produce this same symptom. J. BURGESS, Dunblane.

HT. The smaller primary winding of OPI carries the HT current derived from the cathode of the half-wave rectifier V5 and functions as a hum-bucking device. Resistance smoothing is carried out by R12 in conjunction with dual electrolytic capacitor C18A and C18B. Ripple current rating of C18B should be about 100mA.

Chassis removal. Remove rear panel of cabinet and also the two control knobs from front. Remove the two waxed countersunk screws from cabinet bottom. (Re-wax when reassembling.)

Exercise care when removing chassis because frame aerials are on rear panel and connecting leads are short.

TRIMMING INSTRUCTIONS

(a) Dummy aerial is not used for alignment of the signal circuits. Instead, output of signal generator is connected to a transmitting coil consisting of 13½ turns of 18 SWG enam. copper wire wound on a ½in. diameter former to a length of 1½in. Place this approximately 6ins. from the frame aerial.

(b) LW trimmers must always be adjusted after adjustment of MW trimmers.

| Apply signal as stated below. | Tune receiver to | Trim for max. |
|--|--------------------------|--------------------------|
| (1) 465 kc/s to tag B of frame. | MW, gang to maximum | Cores of L6, L7, L8, L9. |
| (2) 1,500 kc/s to transmitting coil. 600 kc/s to transmitting coil. | MW 200 metres 500 metres | T4 T3 |
| (3) Repeat procedure (2), finally rocking gang while adjusting T3 and T4 for maximum peak. | | |
| (4) 220 kc/s to transmitting coil. | LW 1,362 metres | T2, T1. |

MASTERADIO T512

I EXPERIENCED the following fault with a Masteradio T512:—No vision, sound OK.

Initial inspection showed there was no EHT due to inoperative line-scan circuit. Line oscillator and output valves were replaced with no improvement. Removing the chassis, voltage readings were taken and most of the relevant components in line-scan circuit checked and found to be OK.

This model has two HT rectifiers and associated chokes feeding sound-and-vision unit and timebases respectively, and the fault seemed even more obscure when it was found that on removing the rectifier feeding the sound-and-vision unit the line timebases started working with resultant EHT and raster.

At this stage it was decided to bring the instrument back to the workshop where close inspection revealed that the HT supply to the sound-and-vision unit also fed a double triode (6SL7) used as line and frame sync amplifiers. This was the clue to the fault as the only link between the sound-and-vision HT line and the line timebases was a 44pF condenser via which the line sync pulses were fed to the grid of the line oscillator from sync amplifier anode.

This condenser, when Meggered, was found to be down to a few megohms, placing a small positive voltage on the grid of the line oscillator.—A. J. ADAMS, Balham.