

**VALVE READINGS**

Valve	Type	Electrode	Volts	M.A.
V1	SP4	anode	258	.5
		aux. grid	104	
V2	VP4	anode	258	2.7
		aux. grid	104	
V3	354v.	anode	90	3
V4	Pen.4v	anode	248	35
		aux. grid	260	10

**RESISTANCES**

R.	Purpose	Ohms.
1	Top part of screen ptr V1	20,000
2	Lower part of screen ptr V1	17,000
3	V2 cathode bias	400
4	Series with aerial and V.C.	50
5	V1 cathode bias	2,500
6	V3 grid leak	1 meg.
7	V3 anode coupling	60,000
8	V4 grid stabiliser	5,000
9	V4 cathode bias	300
V.C.	Volume control	8,000
—	L.S. field	1,500
—	Output transformer primary	—

**CONDENSERS**

C.	Purpose	Mfd.
1	V1 aux. grid	.1
2	V1 cathode	.006
3	Osc tracking condenser	.006
4	V2 cathode	.1
5	V3 grid	.0001
6	V3 anode by pass	.002
7	Filter to auto transformer	.1
8	V4 anode tone compensator	.006
9	Electrolytic smoothing	.8
10		.8
C.X.	Between junction of R1 and H.T.; and chassis (not shown in official circuit diagram).	.1

**ORR S.F. SUPERHET FOUR (Cont.)**

speaker field in the positive H.T. lead for smoothing in conjunction with two 8 mfd. electrolytic condensers.

The pilot lamp, an Osram 3.5 volt .3 amp., is connected across only half of the filament winding, one side of which is connected to chassis.

**Special Notes.**—There are two chassis, a power unit carrying the mains transformer, rectifying valve and electrolytic condensers, and the set proper, including the output valve.

The leads between the chassis are sufficiently long to allow either to be removed for examination without entailing disconnections.

**Quick Tests.**—Between terminals on L.S. transformer and chassis (chassis coating is an insulator; negative lead which should be clipped on to a bolt):—

- Inside terminal (1) (H.T. unsmoothed) ... 345 volts
- Next terminal (2) (V4 anode) ... 248 volts
- Middle terminal (3) blank
- Two outer terminals (joined) (H.T. smoothed) ... 260 volts
- V1 anode ... 258 volts

**Removing Chassis.**—The quick tests and valve tests should reveal the chassis in which the trouble lies.

Remove set chassis by undoing the knobs (grub screws) and removing the four bolts underneath. Remove end back-cover support. Take out power pack by undoing four screws underneath.

**General Notes.**—When any heavy work has to be done, the leads between the chassis

must be unsoldered. This is better done at the power pack side. The leads are:—

Brown and pink, twisted (filament) to terminals A and A1 on transformer (see transformer diagram).

Brown, centre tap, to pilot lamp. This can be unsoldered at the lamp.

The earth (H.T.—) connection is the brown filament lead.

Transformer connections (see diagram) are:—A, A1, set filaments; B, C.T. to pilot lamp; C, C1, rectifier anodes; D, C.T. joined to B; E, mains direct; F, 200 volt tapping; G, 210 v. tap; H, 220 v. tap; I, 230 v. tap; J, 240 v. tap; K, K1, rect. filament, C.T. not connected.

The lead to the voltage adjustment plug is connected to the switch.

The layout of this set is open, and the leads are easily followed, so that components can be tested very quickly.

The small capacity coupling the top ends of the band-pass coils consists of short lengths of insulated wire twisted together between the terminals on the tuning condensers. Do not untwist these.

The resistance R4 is contained in the systoflex lead from the aerial terminal to the volume control, while an extra lead going from the same terminal to the switch contains a similar resistance which is connected across the aerial coil at the "local" position of the wave-change switch.

**Replacing Chassis.**—Lay the chassis in the cabinet. Examine the screen between V1 and V2 to make sure it is not touching either valve, as this would short-circuit the bias. Replace the holding screws and the knobs.

If it has been necessary to remove the licence plate to facilitate the withdrawal of the chassis, remember to replace it.

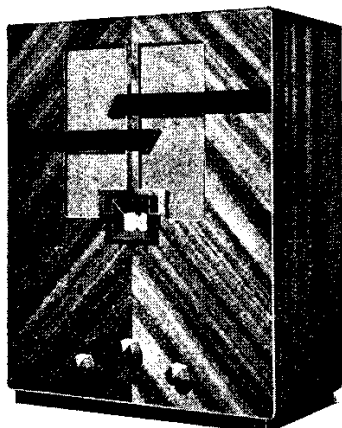

Standard Telephones and Cables' Model "40" is a superhet with only four valves, including the rectifier.

**Circuit.**—A combined first detector oscillator, Cossor MS Pen (V1), is preceded by a band-pass aerial circuit, of which the aerial coil is a tuned secondary transformer.

The feed to the grid of the valve is from a tapping on the second band-pass coil, and this is coupled by a very small 5 mmf. condenser to a second channel suppressor coil on the first band-pass.

**VALVE READINGS**

Valve	Type	Electrode	Volts	M.A.
V1	MS Pen	anode	160	.75 to 1
		screen	50	
V2	MSPen	anode	*100	.2
		screen	30	
V3	7A2	anode	180	26
		aux. grid	195	4

\* This is an anode bend detector and only approximate voltage readings can be taken. Long meter leads cause H.F. instability when testing V1 and L.F. instability (motor boating) when testing V2 directly at the anode terminal. Use short leads.

**MODEL 40 BY STANDARD**

Reaction is obtained by coupling in the cathode circuit and the tuning condenser of the primary of the band-pass intermediate transformer (frequency 130 kc.) is used as a feed to the oscillator.

The second valve, MS Pen (V2), is an anode bend detector, to which a certain amount of reaction can be applied by a semi-variable condenser in series with a reaction winding on the I.F. transformer.

The grid return lead through the I.F.T. secondary is taken to one end of the volume control potentiometer, which also acts by damping the aerial coil. The anode of this valve is resistance capacity coupled to the output valve—the lead containing an H.F. stopper R13 and a decoupling circuit C2,R12.

The output valve, a seven-pin indirectly heated pentode Micromesh 7A2 (V3), has a stabilising resistance, R3, and a tone compensating condenser, C13, in its grid circuit. Cathode bias is used with a 25 mfd. electrolytic condenser.

The mains equipment consists of a transformer, full-wave rectifier Micromesh R2, while the L.S. field is included in the negative H.T. lead, with two 8 mfd. electrolytic condensers for smoothing.

**Special Notes.**—H.T. and heater leads are taken to the sockets on a circular holder at the back of the chassis (behind the pentode valve). These are for use with a short-wave converter, but are useful in testing the filament and H.T. voltages.

The two visible sockets are for heaters, and the end one is insulated and is H.T.+.

The mains adjustment contains a fuse.

**Quick Tests.**—Between side terminals on speaker transformer and chassis (counting from the top):—

- Top (1) is H.T.— and is 130 volts negative (this represents voltage drop across field).
- (2) is V3 anode 180 volts +.
- (3) H.T.+ smoothed 195 volts.
- (4) is connected to chassis.

**Removing Chassis.**—Pull off knobs, remove three screws from underneath, and slide chassis out, removing L.S. connecting plug if necessary.

**General Notes.**—Alternative valves:—  
V1. Micromesh 8A1 or Mullard SP4.  
V2. Micromesh 8A1 or Mullard SP4.  
V3. Pen 4VA.  
Rectifier Philips 1807.

The local-distance switch connects a small condenser (twisted enamelled wire) in series with the aerial (LD on diagram).

The second channel suppressor condenser is also of twisted wire (SC on diagram).

Though the wiring is not so easily followed, the components are easily recognised with the help of the diagram.

When the detector valve has been changed, the trimmer, labelled "Reaction" on the diagram, may have to be readjusted to bring the set back to maximum sensitivity. This trimmer is the exposed one nearest the local-distance switch. The other trimmers should not be touched.

Switch contacts are easily cleaned.

**Mains Transformer Connections.**—

- Outer end: Two red systoflex, rect. fil.
- Two black systoflex, set fil.
- One black braided, chassis.
- Inner end: Two dark red, rect. anodes.
- One black (at end) to switch.
- One yellow to 245V. tap.
- One pink to 225V. tap.
- One green to 200V. tap.
- One black (amongst others) to H.T.— lead.

**Extra Speaker.**—A low-impedance speaker of 1 ohm speech coil is fitted.

For use with internal speaker leave red wandler plug on speaker transformer in G (as it is when it leaves the factory) and plug leads to extra L.S. speech coil into A and B.

For use with external L.S. alone, insert  
*(Continued on next page.)*

### STANDARD MODEL 40 SUPERHET (Contd.)

red plug into A and connect external speaker speech coil to G and B.

**Replacing Chassis.**—First make sure that the screening plate in the bottom of the cabinet is in position, with the holes opposite those in the bottom of the cabinet.

Replace L.S. plug at side and lay the chassis in position. Replace the three screws underneath and press home the knobs.

#### CONDENSERS

C.	Purpose.	Mfd.
1	V2 anode by-pass ... ..	.0003
2	V2 anode decoupling ... ..	.1
3	V2, V3 L.F. coupling ... ..	.01
4	V2 screen ... ..	.1
5	V1 cathode ... ..	.01
6	V1 anode decoupling ... ..	.1
7	V1 screen ... ..	.1
8	Band-pass coupling ... ..	.01
9	V1 Grid ... ..	.0002
10	H.F. by-pass from mains ... ..	.01
11	V3 cathode (low voltage electrolytic).	25 el.
12	V2 cathode (low voltage electrolytic)	25 el.
13	Tone compensator grid V3 ... ..	.0001
14	Smoothering ... ..	8 el.
15	Smoothering ... ..	8 el.

#### RESISTANCES

R.	Purpose.	Ohms.
1	V2 cathode bias ... ..	5,000
2	L.F. coupling, V2, V3 ... ..	250,000
3	V3 grid stabiliser ... ..	100,000
4	V3 grid leak ... ..	500,000
5	V3 cathode bias ... ..	250
6	Top part of screen ptr. to screen V2	250,000
7	Lower part of screen ptr. to screen V2.	50,000
8	Across part of osc. coil ... ..	440
9	V1 cathode bias ... ..	3,000
10	V1 anode decoupling ... ..	50,000
11	Voltage dropping to screen V1	500,000
12	V2 anode decoupling ... ..	40,000
13	H.F. stopper anode V2... ..	15,000
14	V1 grid leak ... ..	1 meg.
15	Grid stopper ... ..	200
—	Volume control ptr. ... ..	10,000
—	L.S. field ... ..	2,600
—	Output transformer primary ... ..	400

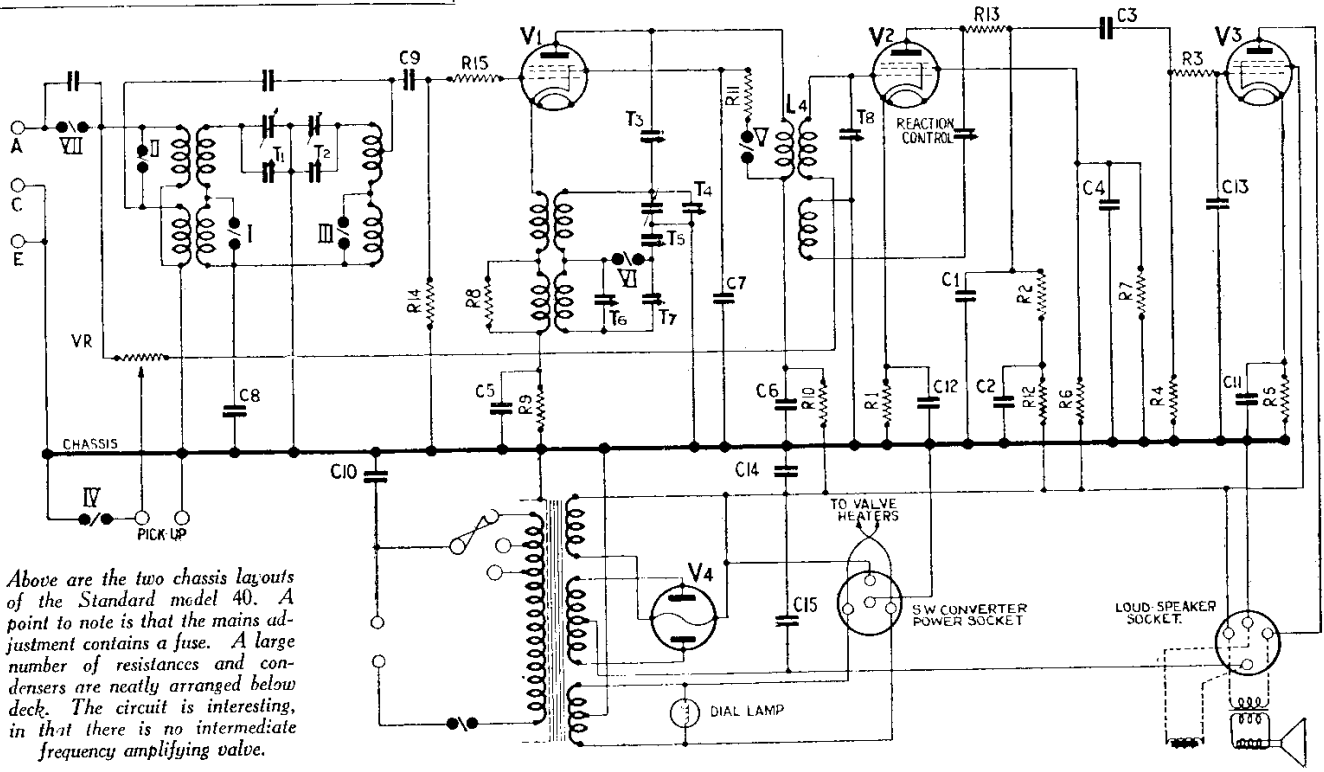
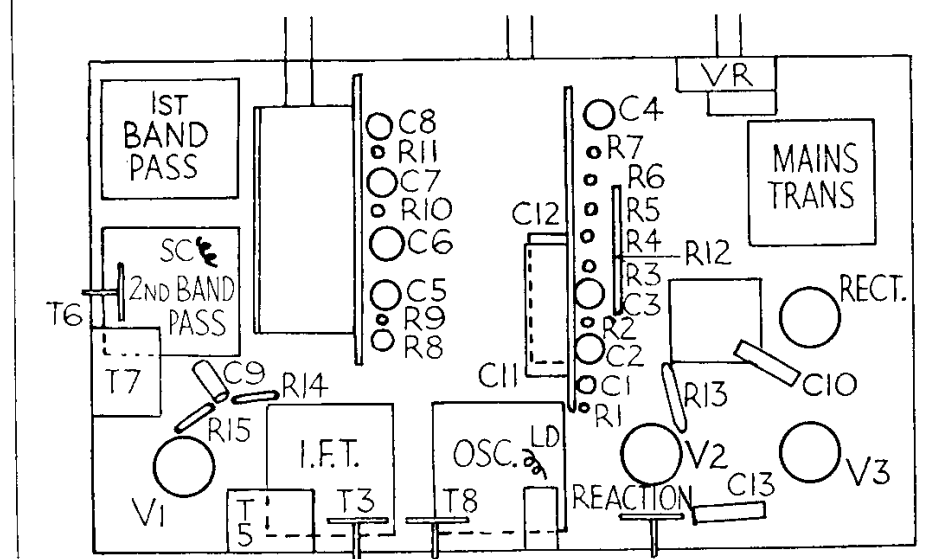
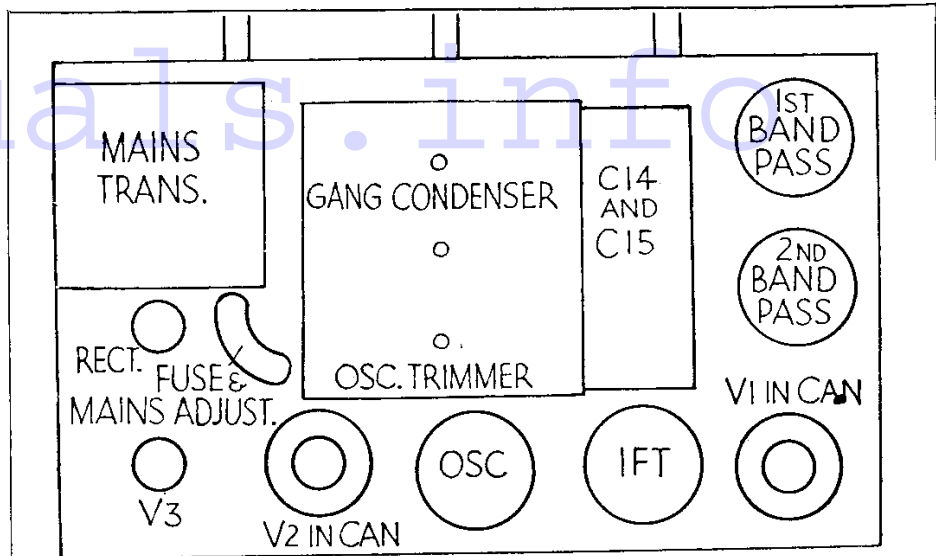

Above are the two chassis layouts of the Standard model 40. A point to note is that the mains adjustment contains a fuse. A large number of resistances and condensers are neatly arranged below deck. The circuit is interesting, in that there is no intermediate frequency amplifying valve.