

PHILIPS 785AX ALL-WAVE FIVE

CIRCUIT.—The aerial is coupled to the grid of V1, an octode frequency changer, via a set of bandpass coils. A suppressor arrangement and an I.F. filter are incorporated in the aerial circuit to neutralise whistle interference on the long and medium bands.

The signal then passes to the I.F. amplifying valve, V2, an H.F. pentode. The I.F. transformer to V2 controls the selectivity by variable coupling between the primary and secondary windings. The output of V2 passes by another I.F. transformer, this time of fixed coupling, to V3, a double diode triode.

One of the diodes of V3 is not used. The other diode acts in conjunction with one of the diodes of V4, a double diode pentode to supply a D.C. potential that is utilised for A.V.C. The other diode of V4 acts as the demodulating diode and rectifies the signal and supplies the potential for operating the visual tuning indicator.

Coupling arrangements to the grid of the triode section of V3 include a manual volume control that is tone compensated by means of condensers.

V3 is resistance capacity coupled to V4, in the anode circuit of which is connected the speaker matching transformer. Across the primary of the transformer is connected a tone correction condenser. The secondary of the transformer is connected to a negative feed back coupling arrangement that reduces distortion. A bass accentuating circuit is incorporated and can be cut out of use by a switch. A variable tone control is also incorporated in this circuit.

Mains equipment consists of a mains transformer with the usual voltage tapplings, a full wave rectifying valve, electrolytic smoothing condensers and a smoothing choke (3,000 ohms).

Chassis Removal.—A false bottom on the cabinet makes the underside of the chassis accessible for inspection. To remove the chassis detach the wave selection switch (the large ribbed knob) from the front of the cabinet, then turn the cabinet on end and remove the false bottom.

Unsolder the connection to the rear of the chassis that earths the screening on the base. Remove the four fixing bolts and washers securing the chassis to the cabinet. The chassis is then free to the extent of sundry leads and cables that lead to the various controls.

It will probably be found unnecessary to remove the chassis as the false bottom enables usual service work to be carried out.

Special Notes.—The voltage adjustment device is located at the rear of the chassis and takes the form of a disc marked with voltage values. This is pulled out of its

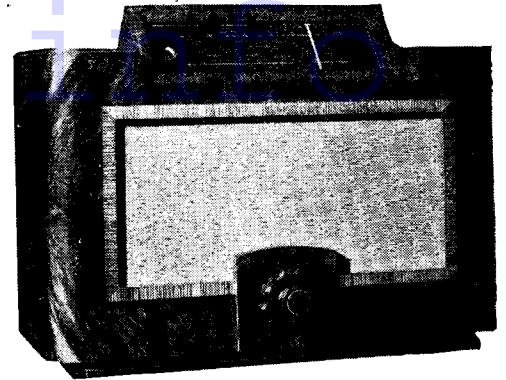

Five valves including rectifier are used in the Philips 785AX three-band super-het. Monoknob control is one of several features.

mounting so that the disc can be turned until the desired voltage is at the top.

A switch at the rear enables the bass response to be cut down if required. A similar switch located near the aerial and earth sockets enables the mains wiring to be used as an aerial. The switch will not engage if the outside aerial is connected.

Sockets enable a pick-up and an external speaker to be connected. An extra speaker should be of the moving-coil type with a speech coil resistance of 5 ohms.

The single control knob has several functions. Pushed in an upward direction, it increases the volume. Pushed to the left, it reduces treble response and increases selectivity, and, pushed to the right, it reduces selectivity and improves fidelity.

There are two dial lights mounted in screw-in holders. They are Philips type 8042.

C51 is to be found at the back of the rectifying valve, R37 is inside the top screening cap of V1, and R30 in the top cap of V4. R14 is located on the tuning indicator valveholder and R12 is inside the screened lead to the volume control.

VALVE READINGS

No Signal. Volume Maximum. 200 volts A.C.
Mains. 1,000 ohms per volt meter.

V.	Type.	Electrode.	Volts.	Ma.
1	FC4 met. (7) ..	Anode ..	233	.8
		Screen ..	45	1.4
		Osc.		
2	VP4B met. (7)	Anode ..	45	1.2
		Screen ..	240	8.3
		Screen ..	142	3.
3	TTD4 met. (7)	Anode ..	55	.7
		Pen 4 DD (7) ..	228	33.
4	Pen 4 DD (7) ..	Anode ..	240	5.5
		Screen ..	240	5.5
5	Philips 1821 (4)	Filament	260	—

Above are Mullard valves

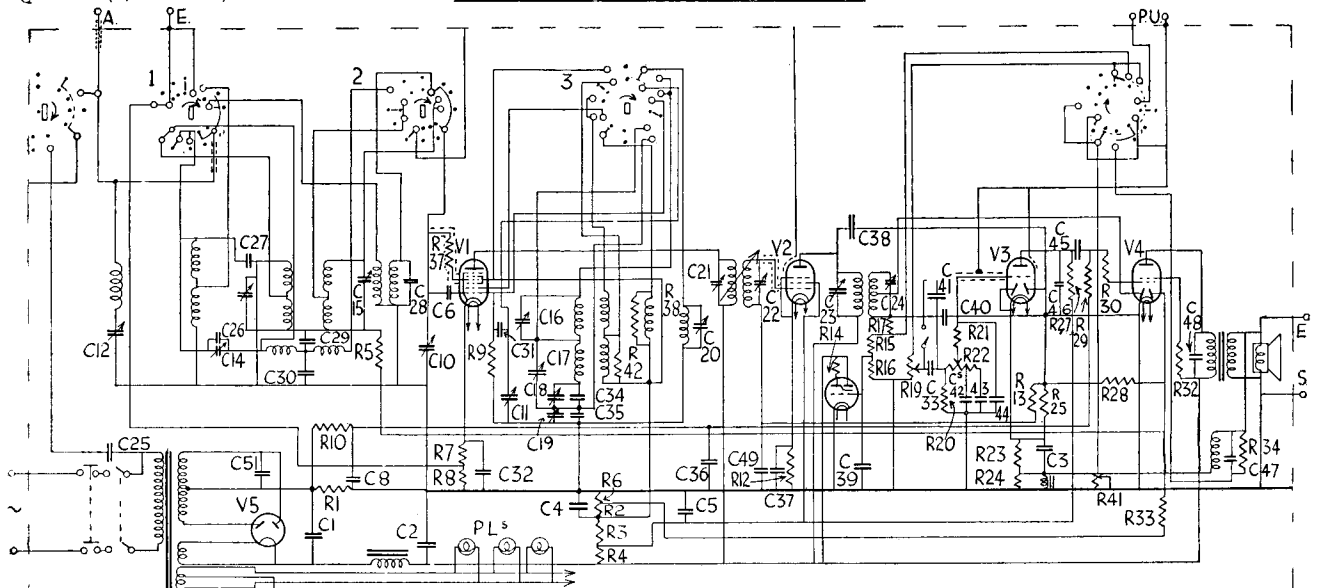

Features to be noted are : aerial whistle suppressor circuit, variable I.F. transformer, and three-diode A.V.C. circuit which prevents speech distortion. Switches are in S.W. position.

For more information remember

www.savoy-hill.co.uk

Circuit Alignment Notes

I.F. Circuits.—Switch the receiver to the long waves and turn to maximum volume and minimum selectivity. Place the A.V.C. out of action by short-circuiting C49 and C36. Connect an output meter to the extension speaker sockets. Short the tone control choke and connect the grid of V1 to chassis.

Damp the secondary of I.F.T.2 with 25,000 ohms and primary of I.F.T.1 with 10,000 ohms and .1 mfd. in series. Inject a signal of 128 kcs. via a .032 condenser to the top grid cap of V1 and trim C23, C22 and C25 respectively for maximum.

Remove the damping and then damp I.F.T.1 secondary with 10,000 ohms and a .1 mfd. condenser between the grid of V2 and chassis, and damp I.F.T.2 secondary with 25,000 ohms and a .1 mfd. condenser between the anode pin of V2 and chassis.

Trim C24, C21 and C24 respectively for maximum and then lock the trimmers with wax. Remove the damping.

Medium Waves.—Fit the 15 degree jig (obtainable from the makers) to the gang and connect the service oscillator via an artificial aerial to the aerial and earth sockets.

Tune the oscillator to 1,442 kcs. and trim C16, C15, C13, C15 and C16 in that order for maximum. Lock C13 and C15 with wax and see the output does not change while the wax is setting.

CONDENSERS

C.	Purpose.	Mfds.
1	H.T. smoothing	32.
2	H.T. smoothing	32.
3	Cathode shunt (part)	50.
4	V1 screen and osc. anode decoupling.	.1
5	V2 screen and V3 anode decoupling.	32.
6	Regeneration control	.000002
8	V4 bias decoupling	.1
25	Mains aerial	.0005
26	I.F. wave trap trimmer	.00002
27	Top a.f. coupling	.00001
28	S.W. grid coil fixed trimmer	.000004
29	Bottom bandpass coupling	.016
30	Bottom bandpass coupling	.025
31	Osc. grid.	.0001
32	V1 cathode shunt	.05
33	L.F. coupling	.0005
34	Osc. fixed padder	.00065
35	Osc. fixed padder	.001375
36	A.V.C. decoupling	.1
37	V2 cathode shunt	.1
38	A.V.C. diode coupling	.00002
39	Indicator grid condenser	.05
40	H.F. bypass	.00005
41	Tone control	.004
42	Tone control	.004
43	Tone control	.004
44	Tone control	.0001
45	L.F. coupling	.008
46	H.F. bypass	.0001
47	Negative feed back condenser	.05
48	Pentode compensator	.002
49	V2 A.V.C. decoupling	.05
51	Mains H.F. bypass	.02

RESISTANCES

R.	Purpose.	Ohms.
1	V4 bias resistance	125
2	V4 control diode bias (part)	32,000
3	V1 screen and osc. anode decoupling.	25,000
4	V2 screen decoupling and V3 anode load.	12,000
5	V1 A.V.C. decoupling	100,000
6	V4 control diode bias (part)	50,000
7	V1 cathode bias (part)	250
8	V1 cathode bias (part)	2,500
9	Osc. grid leak	50,000
10	V4 bias decoupling	320,000
12	V2 cathode bias	250
13	V2 A.V.C. decoupling	2 meg.
14	Indicator H.T. feed	2 meg.
15	Indicator feed pot. (part)	5 meg.
16	Indicator feed pot. (part)	1.6 meg.
17	Demodulating diode load (part)	250,000
19	Volume control	350,000
20	Tone-volume network	800,000
21	Tone-volume network	160,000
22	Tone-volume network	640,000
23	V3 cathode bias	3,200
24	Negative feed back injection.	20
25	A.V.C. diode load	500,000
27	V3 anode load	100,000
28	V4 suppressor diode feed	1 meg.
29	V4 grid leak	400,000
30	V4 grid stopper	1,000
32	V4 screen feed	50
33	V4 suppressor diode load	900,000
34	Negative feed back	800
37	V1 grid stabiliser	32
38	Osc. shunt	10,000
41	Negative feed back control	200
42	Osc. shunt	10,000
	Smoothing choke	3,000

Philips 785AX on Test

MODEL 785AX.—Standard table model for A.C. operation, 100-260 volts, 50-100 cycles. Price 15 gns.

DESCRIPTION.—Three-band, five-valve, including rectifier, table model superhet.

FEATURES.—Full-vision scale with names and wavelengths on all ranges. Monoknob control. Reverse feed back circuit. Bass compensation and bass control. Variable selectivity. Cathode-ray tuning indicator.

LOADING.—71 watts.

Sensitivity and Selectivity

SHORT WAVES (16.7-51 metres).—Excellent gain and selectivity. Marked absence of image frequencies. Easy tuning and no drift.

MEDIUM WAVES (200-585 metres).—Very good gain and selectivity in maximum position. Gain well maintained. Local station spread small. Good background.

LONG WAVES (725-2,000 metres).—Similar performance to medium waves. Usual stations well received.

Acoustic Output

Ample volume for a large room. Negative feed back circuit clearly shows less distortion at full volume. Tone exceptionally good, with very fine bass and good top and clean attack. Speech very natural in maximum fidelity position.

Earth the grid of V1 via a .1 fixed condenser and tune the service oscillator to 546 kcs. Connect an auxiliary receiver through a .000025 condenser to the wire bared for the purpose and accessible through a hole in the chassis deck between V1 and V2. Connect the output meter to the auxiliary receiver and tune the said receiver to 546 kc. Tune the condenser of the 785AX to maximum output.

Remove the auxiliary receiver and reconnect the output meter to the receiver under test. Trim C19 and then lock. Tune the oscillator to 1,442 kcs. and set the gang to the jig. Lock C16 and adjust to maximum output while the wax is setting.

Long Waves.—Tune the set and oscillator to 758 metres (395 kcs.), adjust C17 for maximum, lock, and if necessary, readjust whilst the wax is setting.

Tune the set to 1,875 metres (160 kcs.), turn the gang to maximum and then turn back until the second maximum output point is reached. Trim C18, lock, and if necessary, readjust whilst the wax is setting.

Short Waves.—Set the gang to the jig. Tune the oscillator to 17.05 mcs. and open C20 until the first maximum output point is reached. Then lock the trimmer and readjust if necessary whilst the wax is setting.

Image Frequency Filter.—Switch the receiver to the short waves and tune the service oscillator to 1,000 kcs. Feed a strong signal to the set. Adjust the pointer to read 403 metres and trim C14 for minimum response.

I.F. Aerial Filter.—Switch the receiver to the long waves and turn the gang to maximum. Tune the oscillator to 128 kcs. and trim C12 for minimum.

Condenser replacements are available from A. H. Hunt, Ltd., for C3 and for the unit used for C's 1, 2 and 5. These are units 2915 at 1s. 9d., and 2989 at 7s. 6d., respectively.

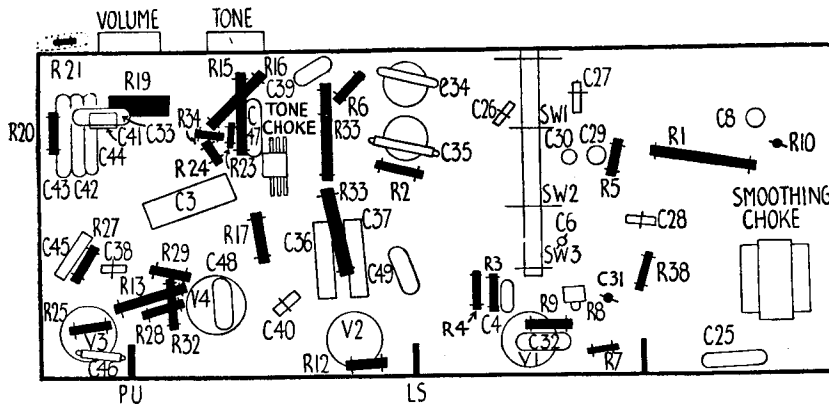

Above, is the diagram showing how parts are situated underneath the chassis of the 785 AX. The "top deck" view is given on the right. C14 and C15 are between the band-pass coils and the gang.

