

G.E.C. SUPERHET FIVE (Cont.)

chassis. (Console, BC13444.). Suffix "K" denotes Catkin model.

Wiring Colour Code.—

- Grid wiring, green; HT+, red.
- Anode wiring, orange; HT-, slate.
- Cathode, pink; Earth, black.
- Screening grids, blue.

Preliminary Tests.—Full eliminator voltage of 330-340 volts between two left-hand terminals on speaker transformer. Voltage drop of 75 across field, left-hand (-) and right-hand (+) terminals.

Removing Chassis.—Pull off the control knobs and undo four screws from underneath cabinet. Rubber washers may make them seem stiff. Withdraw chassis, leaving speaker leads connected for chassis tests.

Removing Speaker.—Do not unbolt speaker from its own baffle. Unscrew the baffle from the cabinet and undo the speaker switch from its bracket.

Stand the set on the mains transformer end for tests.

If trouble develops in any of the tuning or intermediate coils the set should be returned to the makers.

If one or more condensers in the block become defective and suitable values of the

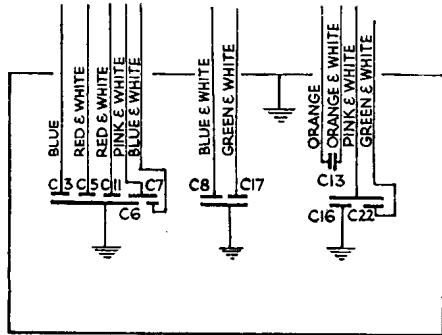

BLOCK CONDENSER

small tubular type cannot be suspended in the wiring the block should be removed.

All the wires are coded and it is immaterial which red and white lead is taken to R2 and R12. The condensers are identical.

As the full voltage drop across the L.S. field exists between the case of C19 the can is insulated from points at chassis potential.

Replacing the Chassis.—Replace and screw up the speaker baffle. Replace chassis and screw in the four bolts and press the knobs on to the spindles.

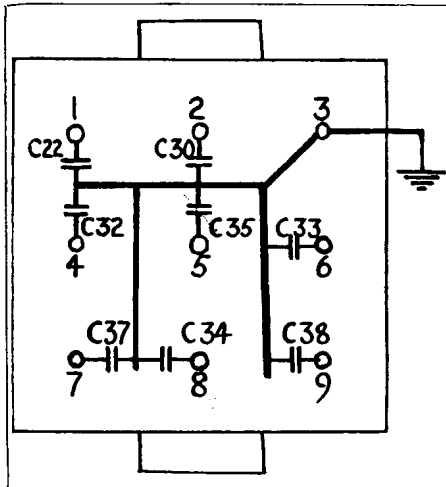

This diagram, in conjunction with the condenser "key" panel, shows the capacities of the units in the condenser blocks of the Philips 634 A.

PHILIPS 634A "STRAIGHT"

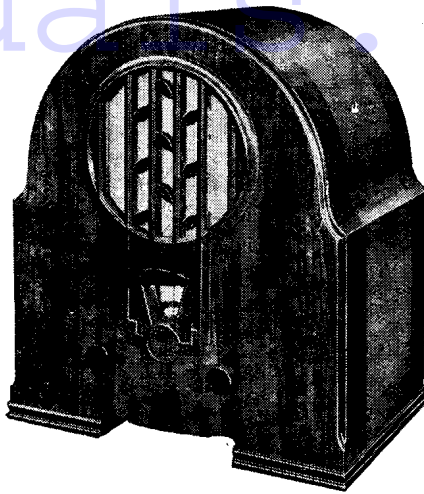

As a sensitivity control is ganged with the tuning knob of the Philips 634A, the scale should be turned to maximum when taking valve current and voltage measurements.

between R16, R17 provides bias for the S.D.T. grid, which is decoupled.

Special Notes.—This receiver appears more complicated than it really is. Philips own slip-on resistances are used and are obtainable from the makers. (The soldering iron should not be too hot.)

The sensitivity switch operates by connecting R30 in parallel with R18 and part of R4 to lower the minimum bias on the H.F. valves.

In some cases an extra condenser may be

VALVE READINGS

(Tuning scale at max.* Sensitivity switch out.)

Valve.	Connection.	Volts.	M.A.
V 1, S4VB ...	anode ...	215	2.5
	screen ...	95	
V 2 S4VB] ...	anode ...	215	5.5
	screen ...	95	
V 3 S4D ...	anode ...	70	.5
V 4 PM24A ...	anode ...	210	15
	aux. grid ...	208	4.5

* The resistance R 4 is ganged to the tuning, and consequently alters the bias.

CONDENSERS

	Purpose.	Mfd.
C 1	Coupling to tetrode grid V 3	.01
C 2	HF by-pass V 3	.0002
C 3	Aerial input filter	.0001
C 17	Across valve filament	.1
C 19	H.F. feed to diode anode	.13mmf.
C 20	Band pass coupling	.025
21	Band pass coupling	.04
22	Decoupling bias circuit V 3	.25
23	Anode by-pass V 3	.00025
24	LF coupling V 3, V 4	.002
26	Tone control V 4	.01
27	Tone control V 4	.032
28	Tone corrector V 4	.002
29	Decoupling anodes V 1, V 2	.1
30	Part of AVC system	.1
31	Diode output filter	.00001
32	Decoupling bias circuit V 2	.25
33	Decoupling SG, V 3	.5
34	Decoupling SG's, V 1, V 2	.5
35	Decoupling anode V 3	1
36	HF decoupling aux. grid V 1	.1
37	Decoupling grid, V 4	.1
38	Decoupling aux. grid, V 4	.1
39	Electrolytic smoothing	16
40	Electrolytic smoothing	16
41	Short circuiting and across LW and HF trans.	1.04
42	Short circuiting and across LW grid, V 2	.04

Circuit.—The first H.F. valve V1 (S4VB) is preceded by a band-pass aerial circuit and is coupled to the second H.F. valve V2 (S4VB) by a tuned secondary H.F. transformer. A similar transformer couples V2 to the diode section of the single diode tetrode detector V3 (SD4), and true automatic volume control is employed from the plate of the diode to the grid circuit of the first H.F. valve. In addition, a compensating sensitivity control R4 is made automatic by ganging with the tuning condensers.

The amplifying section of the S.D.T. valve is resistance capacity coupled to the grid of the pentode output which is compensated and fitted with a manual tone-control three-way switch. The speaker is a permanent-magnet moving-coil.

Full-wave rectification is used, and smoothing is by resistances R4, R16, R17 in the negative H.T. lead in conjunction with 16 mfd. electrolytic condensers. The tapping

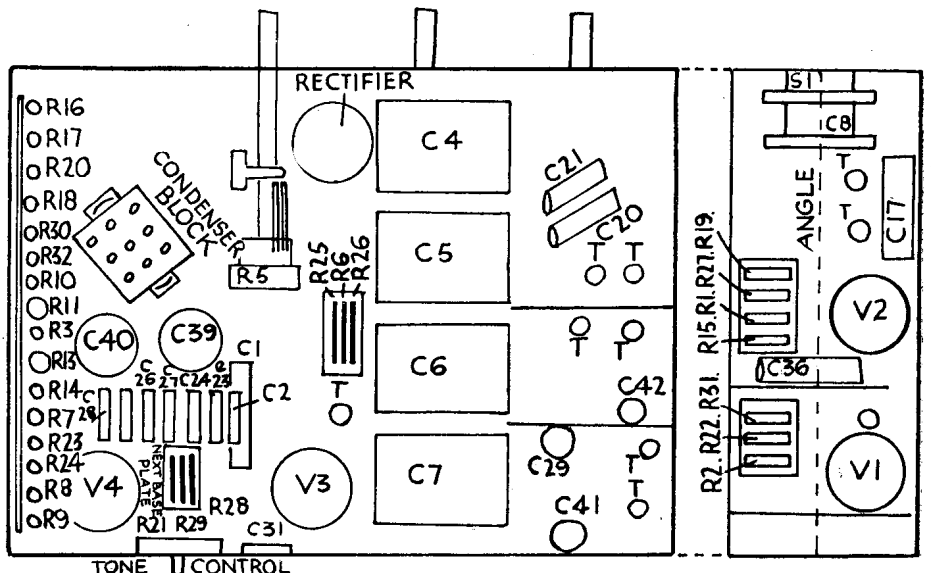

TONE CONTROL

Under chassis arrangement of resistances and condensers in the Philips 634A five-valve A.C. mains receiver. On the right is shown the layout of components on the end of the chassis.

FIVE-VALVE A.C. MAINS RECEIVER

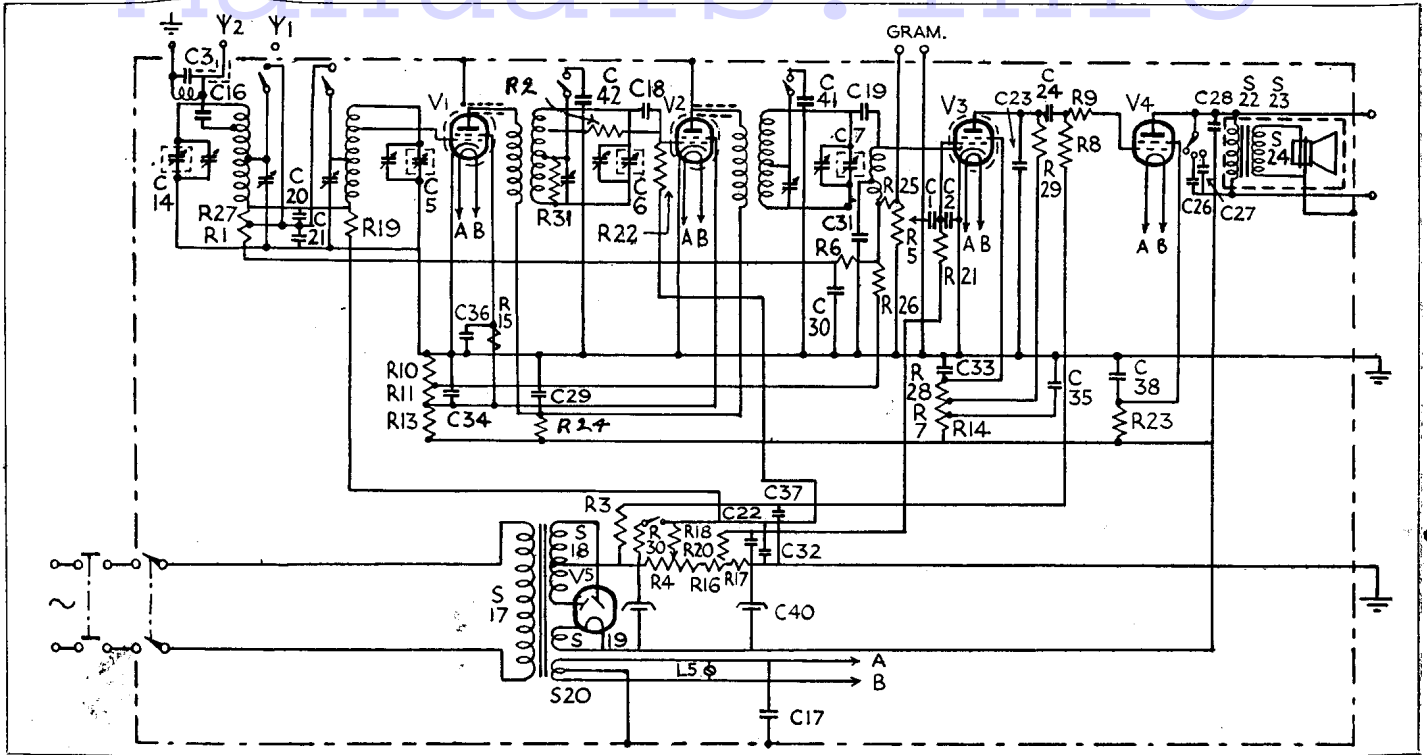

A unique feature of the Philips 634A receiver is the exclusive use of resistances for smoothing. Altogether there are a large number of resistors employed, and this makes the chassis appear complicated. The construction, however, is planned for accessibility, with the result that servicing is not difficult.

(Continued from previous page.)

found between the grid of the pentode and earth in the position shown in the lay-out diagram between C28 and C26.

The low A.C. potential ends of C26 and C27 of the tone filter may be connected to earth direct instead of through the electrolytic condensers.

In some models a fuse is mounted on the mains transformer; this is between H.T.+ (rect. filament) and C39.

If hum is experienced, change round the leads to the H.F. filter.

Removing Chassis.—Caution: First

turn variable condenser to min. and note the exact reading A0 or O1.

Remove valves. Disconnect earthing lead to L.S. Unsolder the leads to output transformer.

Remove screws from mains supply plate at top of cabinet, and four chassis holding screws from underneath. Remove knobs from front (grub screws).

In handling this chassis, take care not to strain any of the containers nor alter the position of the wiring. Any alteration would seriously impair performance.

Note.—In the event of any trouble developing in the tuning coils, condensers, or the small sealed trimmers, the set must be returned to the makers.

Removing Speaker.—Disconnect the leads and remove nuts from the three clamps.

When a new cone and coil assembly is required, this can be obtained from the makers with a new clamping ring.

General Notes.—The wiring is not coded, and when a component has to be replaced the wiring should be labelled. To facilitate this for the block condenser we have numbered the terminals; the condensers give the connections.

The mains transformer connections are:— Electrolytic condenser side, *next baseplate*: outers, set filaments; middle, C.T. Five upper terminals from outside and H.T.—, Rect. fil., Rect. Anode, Rect. fil., and Rect. Anode.

The mains connections are on the front panel and should be marked before disconnecting.

Reassembling Chassis.—Turn condenser back to minimum position and replace chassis in the cabinet.

Replace the loudspeaker and reconnect the wires.

Check the calibration and replace four holding screws and control knobs.

RESISTANCES

R	Purpose.	Ohms.
R 1	Part of AVC system ..	10,000
R 2	Grid circuit of V 2 ..	1.6 meg.
R 3	Decoupling grid V 4 ..	.5 meg.
R 4	Auto sensitivity control ..	550 meg.
R 5	Diode output pot. ..	.5 meg.
R 6	Part of AVC circuit ..	2 meg.
R 7	HT feed to V 3 ..	64,000
R 8	Grid leak, V 4 ..	1 meg.
R 9	HF stopper grid, V 4 ..	.5 meg.
R 10	Part of S.G. feed ..	3,200
R 11	Part of SG feed ..	20,000
R 13	Part of SG feed ..	20,000
R 14	HT feed to V 3 ..	25,000
R 15	HF decoupler SG of V 1 ..	1,000
R 16	Bias pot. and smoothing ..	250
R 17	Bias pot. and smoothing ..	64
R 18	Decoupling grid, V 2 ..	2.5 meg.
R 19	Decoupling grid, V 1 ..	4 meg.
R 20	Decoupling grid, V 3 ..	.8 meg.
R 21	Grid leak tetrode grid, V 3 ..	1 meg.
R 22	Grid leak, V 2 ..	3.2 meg.
R 23	Decoupling aux. grid, V 4 ..	4,000
R 24	HF anode decoupler ..	1,000
R 25	Part of diode output pot. ..	50,000
R 26	Part of AVC system ..	5 meg.
R 27	Part of AVC system ..	2 meg.
R 28	HT feed to SG of V 3 ..	4 meg.
R 29	Anode coupling, V 3 ..	.1 meg.
R 30	Sensitivity bias resist ..	2 meg.
R 31	Damping LW section, 1st HF trans. ..	.32 meg.

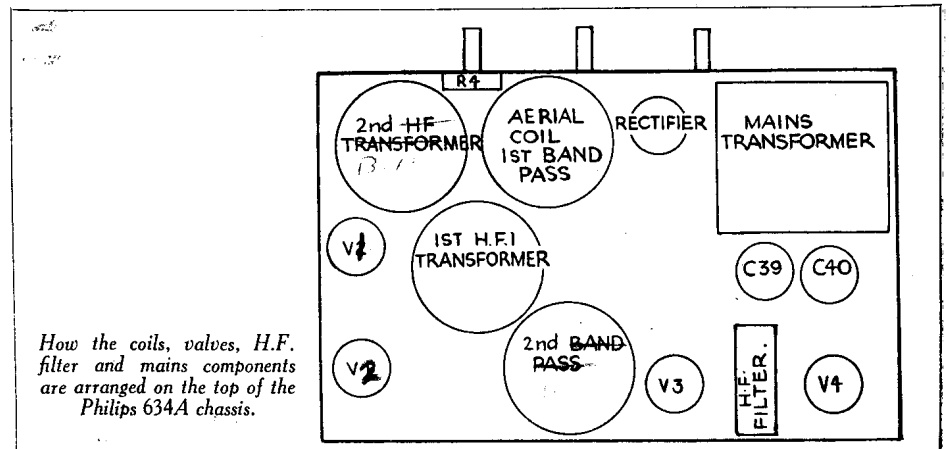

How the coils, valves, H.F. filter and mains components are arranged on the top of the Philips 634A chassis.