

# PHILIPS 290U

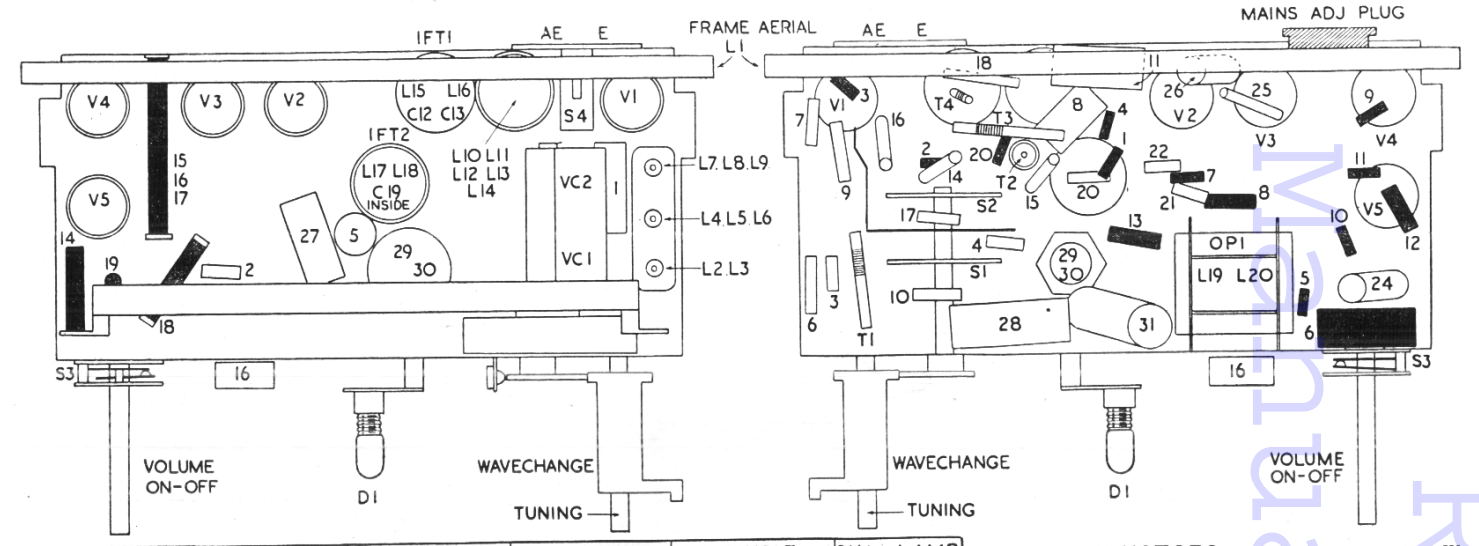
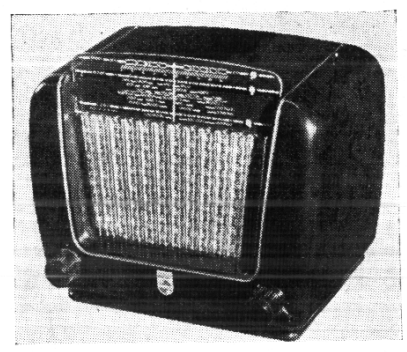

<b>V1—UCH 42</b> Gt G3 G2 G4 At 102V 4.6MA A1 165V 2.2MA H H K O V	<b>V2—UAF 42</b> G3 G2 75V .9MA D G1 A 165V 4.7MA H H K S O V	<b>V3—UBC 41</b> S D2 D1 G A 60V .22MA H H K S O V	<b>V4—UL 41</b> G2 165V 8.5MA G1 A 177V 48MA H H K G3 8.5V H H	<b>V5—UY 41</b> A 195V RMS H H K 190V 68MA H H	<b>110 VOLT</b> (SEPARATE PLUG) A G E D C B F	<b>210 VOLT</b> A G E D C B F	<b>240 VOLT</b> A G E D C B F	<b>DIAL—LAMP</b> PHILIPS TYPE 8097D—00
					<b>MAINS VOLTAGE</b>	<b>ADJUSTMENT</b>	<b>PLUG CONNECTIONS</b>	

**INDUCTORS**

L	Ohms	R	Ohms	W
4	2.7M	...	...	...
5	10K	...	...	...
6	500K potr.	tapped 50K	...	...
7	100K	...	...	...
8	10M	...	...	...
9	470K	...	...	...
10	820K	...	...	...
11	100K	...	...	...
12	150	...	...	...
13	1K	...	...	...
14	200 WW	...	6	...
15	150 WW	...	1 1/2	...
16	150 WW	...	1 1/2	...
17	530 WW	...	5.3	...
18	2 to 3.5K	Temco	...	...
19	8 to 15K	Temco	...	...
20	12K	...	...	...

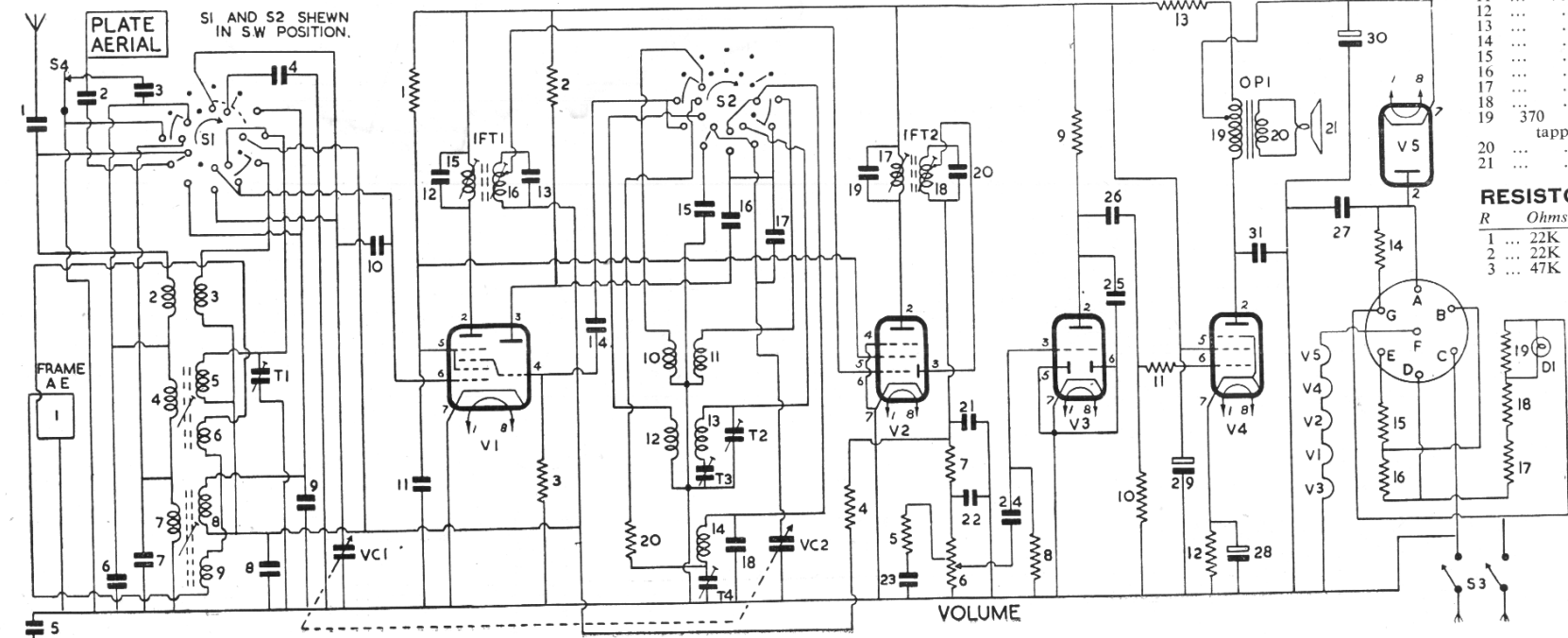

**CAPACITORS**

C	mF	Type
1	1000pF	Tubular 800V
2	47pF	Ceramic Tubular
3	100pF	Ceramic Tubular
4	120pF	Ceramic Tubular
5	4700pF	Tubular 800V
6	15pF	Tubular Ceramic
7	15pF	Tubular Ceramic
8	.047	Tubular 125V
9	18pF	Tubular Ceramic
10	220pF	Tubular Ceramic
11	.047	Tubular 400V
12	115pF	Tubular Ceramic
13	115pF	Tubular Ceramic
14	82pF	Tubular Ceramic
15	180pF	Tubular Ceramic
16	220pF	Tubular Ceramic
17	190pF	Tubular Ceramic
18	20pF	Tubular Ceramic
19	102pF	Tubular Ceramic
20	102pF	Tubular Ceramic
21	82pF	Tubular Ceramic
22	47pF	Tubular Ceramic
23	.018	Tubular 125V
24	3900pF	Tubular 400V
25	390pF	Tubular Ceramic
26	6800pF	Tubular 400V
27	.022	Tubular 600V
28	100	Electrolytic 12V
29	50	Electrolytic 300V
30	50	Electrolytic 300V
31	.022	Tubular 800V

**RESISTORS**

R	Ohms	W
1	22K	1/4
2	22K	1/4
3	47K	1/4

# PHILIPS 290U-

Continued

Five-valve, three-waveband superhet fitted with frame and plate aerials and sockets for external aerial and earth. Bandspreading is provided on 25 and 31 metres SW bands. Suitable for 100-120, 200-250 volt AC/DC mains. Housed in brown moulded plastic cabinet. Made by Philips Electrical, Ltd., Century House, Shaftesbury Avenue, London, WC2.

**AERIAL.** A frame aerial L1 consisting of an open-ended metal frame attached by insulated bolts to rear section of chassis is provided for MW, LW reception. The frame, which is earthed to chassis at one point, is coupled by L6, L9 to the MW and LW tuned coils L5, L8 respectively.

For SW reception the metal shield of dial cursor assembly is used as a plate aerial, the signal being fed through isolating capacitor C2 and contacts on S1 to SW aerial coupling coil L2. Sockets are provided for an external aerial and earth, the aerial being fed through isolating capacitor C1 to top of series connected aerial coupling coils L2 (SW), L4 (MW), L7 (LW). S4, which is operated by insertion of aerial plug into socket, disconnects C3 from junction of L2, L4 to maintain correct aerial input loading. When S1 is in SW position L4, L7, C6 are shorted down to chassis. Earth socket is isolated from chassis by C5.

The grid coils L3 (SW), L5 (MW), L8 (LW), are switched by S1 to triode-hexode frequency changer V1. On SW position of S1 the aerial tuning capacitor VC1 is shunted by C4 and coupled through C10 to L3. On MW band C10 is shorted out, and C4, together with L8, C9 (LW), are shorted down to AVC line, thus leaving L5 (MW) tuned by VC1 and trimmed by T1. On LW band L8, trimmed by C9, is tuned by VC1, L5 (MW) being short-circuited to AVC line and C10 remaining shorted.

AVC, decoupled by R4, C8, is fed through the tuned coils to V1. Cathode is at chassis potential. Screen (g2, g4) voltage is obtained from R1 and decoupled by C11. Primary L15, C12 of IFT1 is in the hexode anode circuit of V1.

**Oscillator** is connected in a tuned anode shunt fed circuit. The anode coils L11 (SW), L13 (MW), L14 (LW) are switched by S2 through C16 to oscillator anode of V1 of which R2 is load. On SW range the oscillator tuning capacitor VC2 is shunted by C15 and coupled through C17 to L11.

It should be noted that the SW band is bandspread by reducing the tuning range of the oscillator. At the low frequency end of the band the oscillator frequency is higher than the signal frequency by the amount of the IF, whilst at the high frequency end of the band the oscillator frequency is less than the signal frequency by the amount of IF. The range of aerial and oscillator tuning is reduced to the required value by the shunt and series capacitors which are switched in by S1, S2 to VC1 and VC2. The cross over frequency occurs at a point where no transmission is likely to be heard.

On MW range, L13 trimmed by T2 and padded by T3 is tuned by VC2, C17 being shorted out and C15 disconnected from across VC2. The LW tuned circuit is placed inoperative by having L11 (SW) shunted across it.

On LW range, L14, trimmed by C18 and padded by T4, is tuned by VC2. Grid reaction voltages

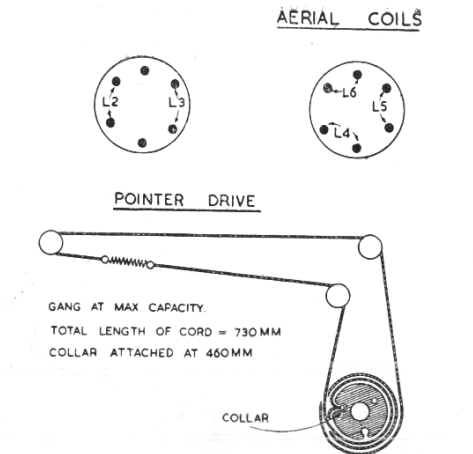

are obtained inductively from L10 (SW), L12 (MW) and capacitively from across T4 (LW) and are switched by S2 through C14 to oscillator grid of V1. R20 is LW limiter. Automatic bias for grid is developed on C14 with R3 as leak resistor.

**IF amplifier** operates at 470 kc/s. Secondary L16, C13 of IFT1 feeds signal, and AVC voltages decoupled by R4, C8 to g1 of IF amplifier V2. Cathode and suppressor are strapped and connected down to chassis. Screen voltage is obtained from R1 decoupled by C11. Primary L17, C19 of IFT2 are in the anode circuit.

**Signal rectifier.** Secondary L18, C20 of IFT2 feeds signal to diode anode of V2. R6, the volume control, is the diode load and IF filtering is given by R7, C21, C22.

Tone control is given by R5, C23, which are connected between 50K ohms tapping on R6 and chassis. The degree of top cut progressively increases as the volume is reduced.

AVC. The DC component of the rectified signal is decoupled by R4, C8 and fed to V1, V2.

**AF amplifier.** C24 feeds signal from volume control R6 to grid of triode section of V3. Cathode is at chassis potential, and bias for grid is developed on C24 with R8 as leak resistor. The two diode anodes of V3 are not used, and are therefore earthed to chassis. R9 is anode load and C25 is an RF bypass capacitor.

**Output stage.** C26 feeds signal from anode of V3 through stopper R11 to g1 of pentode output valve V4. R10 is grid resistor, and cathode bias is provided by R12 decoupled by C28. Screen voltage is obtained from R13 and decoupled by C29. Primary L19 of OPI, the output matching transformer, is in the anode circuit. Fixed tone correction is given by C31. Secondary L20 feeds signal to a 5in. PM loudspeaker L21.

**HT** is provided by an indirectly-heated half-wave rectifier V5. On 100-120V mains its anode voltage is obtained direct from input, but on 200-250V it is obtained from input through dropper and limiter R14. Smoothing is given by R13 and section of primary L19 of OPI together with C29, C30. Modulation hum is eliminated by C27.

## OSC COIL

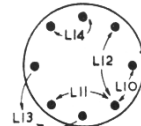

are stator contacts on face, whilst inner ring are those on rear of switch wafer. Dots indicate unused or vacant stator contacts. Rotor contacts shown as full lines appear on face and that in the dotted line at rear. Rotor contacts shown by a line connecting inner and outer rings represent contacts which pass through rotor discs and operate on both sides of wafer.

**Chassis removal.** Undo and remove grub screws in the two front control knobs and remove knobs. Remove combined rear and base cover—held by two screws at back and two under bottom. Unsolder plate aerial lead from C2 mounted on paxolin strip just above loudspeaker and also LS leads from tags on OP1. Pull out the wavechange knob as far as it will go. Loosen dial cursor clamping screw and slip cord out from under clamp plate. Undo and remove screw at side of each pulley support and the two screws at front of base of cabinet. Chassis can now be withdrawn from out of cabinet.

## FLASH-OVER OF FLYBACK EHT

ONE TV model has been prone to flash-over in the EHT flyback transformer. Replacements from the makers were no better and I finally resorted to swamping all danger points with—yes, just plain candle grease, packed well in to small places while still warm.

In another set which was apt to give off ozone and give a beautiful display of sparks running up and down the over-wound EHT winding I applied the candle-grease cure and also replaced the EHT valve rectifier by a Westinghouse metal unit. EHT was slightly reduced, but regulation improved a little, and transformer flash-over eliminated.

EHT troubles can be due to too sharp a line oscillator waveform and the resistor included to limit the discharge of the "charging" condenser in the oscillator circuit should be checked and, perhaps, increased in value.—P.I.C.

## HIGH RESISTANCE SWITCH

A PYE four-valve all-wave battery superhet lacked punch and tended to be intermittent in operation. All anode and screen voltages were normal, and a complete change of valves effected no improvement.

It was decided to concentrate on the lack of volume rather than on the cause of the intermittency and so every suspect component was carefully checked.

Eventually the reason was found—there was a .2V drop across the LT side of the DPST switch incorporated in the volume control.

All the valves, even with a freshly charged accumulator, were getting an insufficient LT supply while, when the accumulator did run down slightly due to this excessive voltage drop across the switch, the LT supply to the FC2 frequency-changer was insufficient to allow it to oscillate—hence the intermittent action.—G.R.W.

## TRIMMING INSTRUCTIONS

Apply signal as stated below	Tune Receiver to	Trim in Order stated for Max. Output
(1) Remove combined rear and baseplate.		
(2) IFT2 is preset tuned. Feed signal via .032 capacitor to g1 of V2 and determine frequency to which IFT2 is aligned		
(3) Apply this frequency to g1 of V1 via .032 capacitor	—	Core L15 Bottom " L16 Top
(4) Adjust dial pointer to "M" of metres on left-hand side of scale on LW band		
(5) SW range components are all preset—No trimming is therefore possible		
(6) 1.55 mc/s to AE socket via dummy aerial	200 metres cal. mark	T2, T1
(7) 575 kc/s as above	525 metres cal. mark	T3. Repeat (6) and (7)
(8) 160 kc/s as above	LW band and use above cal. mark	T4