

Left, how the parts are situated on the top of the Ferranti universal chassis. Right, the underneath layout. The condenser block on the right of the chassis—it is not shown—contains C20 & C21.

(Continued from opposite page.)

.002, 1 red spot; .0003, 1 yellow spot; .0003, 2 yellow spots; .0004, 2 red spots; .0005, 1 green and 1 yellow spot; .0006, green and 1 red spot; .001, 1 green

spot; .0016, 2 blue spots; .00175 1 blue spot; .002, 1 brown band; .01, 1 green band; .02, 1 yellow band; .05, 1 red band; .1, 1 green band; .01, 2 green bands; .05, 2 red bands; .1, 2 grey bands.

**Replacing Chassis.**—Lay chassis inside cabinet, replace holding screws and control knobs.

Connect the speaker leads to their corresponding plugs.

## PHILIPS TWENTY-WATT AMPLIFIER

**Circuit.**—The input to the first valve, F4160 (V1), is through a condenser to the grid and direct to the cathode.

Cathode bias is used and the input is properly decoupled.

The output circuit of this valve is coupled to the transformer by links, which allow the output valve to be used alone with a set or other amplifier. To form an independent H.T. feed for the output valve of the preceding set the choke L11 is connected across the input, and the transformer is condenser fed.

The output valve, MC 1/60 (V2), is a directly heated valve and a special form of hum neutralising is obtained by feeding the A.C. from R5 (across the heater winding), through C6 to the choke L8, which forms part of the L.F. coupling to the grid.

The output transformer has a multi-tapped secondary, and a safety neon cartridge is connected across the full winding.

**Special Notes.**—Everything accessible from the outside is labelled, and the various combinations of connections for speakers are easily understood.

The lettered connections should be connected by links as follows:—

For gram : A to B and C to D.

For radio : A to C and use C and D as input terminals.

E and F should be strapped together, except when a milliammeter is connected between them.

A pilot lamp of 4 v. .35 amp. can be connected between G and H.

The voltage between terminal A and chassis should be between 270 and 330 volts.

**Revealing Chassis.**—Remove two screws from front of perforated cover and three

### RESISTANCES

R.	Purpose.	Ohms.
2	V1 grid leak .. .. .	.2 meg.
3	V1 grid decoupling .. .. .	.32 meg.
4	V1 cathode bias .. .. .	250
5	Artificial centre of V2 filament .. .. .	45
6	Part of H.T. ptr. .. .. .	50,000
7	Part of H.T. ptr. .. .. .	50,000
8	Part of V2 bias ptr. .. .. .	100
9	Part of V2 bias ptr. .. .. .	1,350

### CONDENSERS

C.	Purpose.	Mfd.
1	H.T. smoothing .. .. .	2
2	H.T. smoothing .. .. .	2
3	V2 bias decoupling .. .. .	2
4	Input to V1 grid .. .. .	.1
5	V1 grid decoupling .. .. .	.1
6	Series with hum adjustment .. .. .	2
7	Filter to L.F. transformer .. .. .	2
8	Filter to L.F. transformer .. .. .	.125

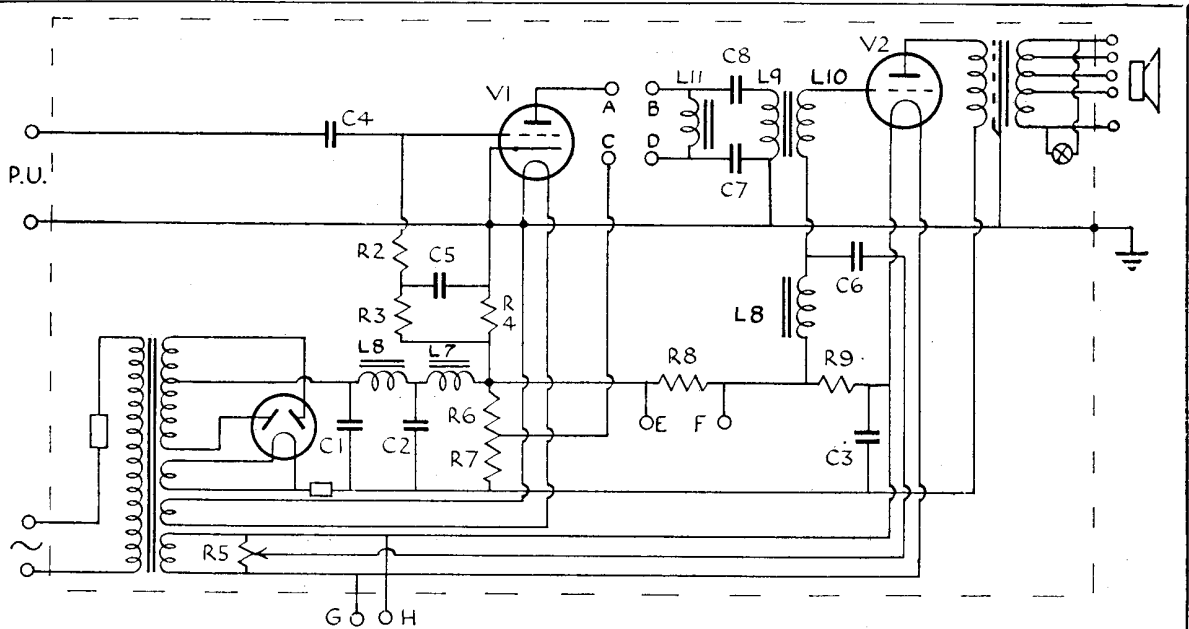

Two triodes in two stages form the basis of the Philips 3750 amplifier. Links on the input side of the L.F. transformer enable the output valve to be fed straight from a radio receiver.

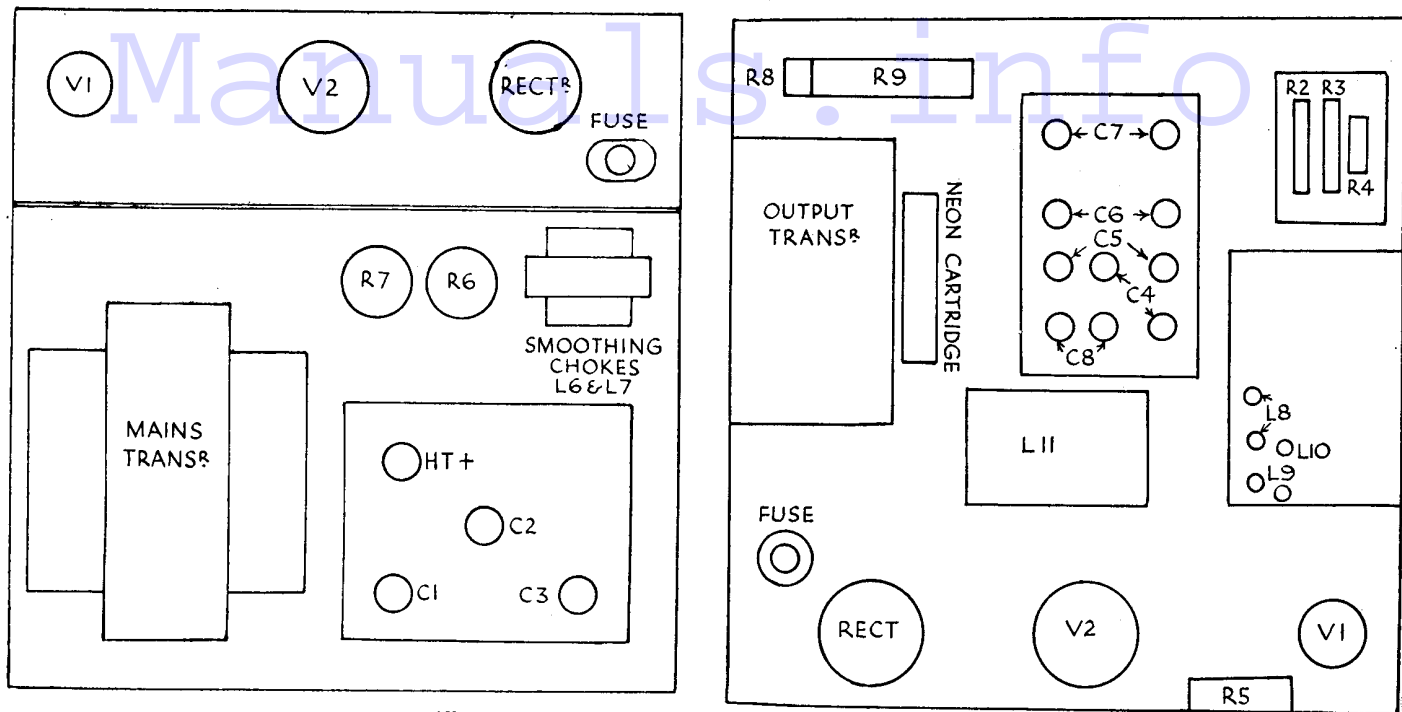

The practical layout diagrams of the Philips 3750 P.A. amplifier.

(Continued from previous page.)

screws from the flange at each side of the base and remove the four screws inside the rubber supports.

**General Notes.**—The voltages in this amplifier are in the neighbourhood of 1,000 volts, and due care must be taken.

The wires are bunched, and to facilitate the tracing of leads a continuity tester is an advantage.

**Replacing Cover.**—In replacing the cover it is better to replace the bottom plate and fix by the two screws underneath the valve platform.

The remaining two screws should not be

inserted till after the perforated cover has been replaced.

**VALVE READINGS**

Valve.	Type.	Electrode.	Volts.	M.A.
1	F 4/60 ..	anode ..	270-330	9.5-10.5
2	MC 1/60 ..	anode ..	950-1050	48-52

# GENERAL ELECTRIC D.C. FIVE

**Circuit.**—The first detector oscillator valve, DSB clear (V1), follows a band-pass aerial coupling. As it is a screen-grid valve, reaction coupling is in the cathode lead, with suppressor feed to the aerial coil.

Coupling to the next valve is by band-pass I.F. transformer (frequency 107 kc.), and the tuning condenser of the primary is used as the H.F. feed to the anode reaction coil.

The I.F. valve, VDS clear (V2), is followed by a second band-pass I.F. transformer, and volume is controlled by means of a potentiometer, R21, which simultaneously damps the aerial and increases the bias on V2.

A DSB clear second detector (V3) operates as an anode-bend detector, and gramophone coupling is obtained from the low H.F. potential end of the secondary of I.F.T.2 and cathode through two isolating condensers. The anode circuit consists of a resistance and by-pass condenser I.F. filter, a resistance capacity L.F. coupling and anode decoupling.

A filter for double the intermediate frequency (214KC) is included in the anode circuit (L7 C38).

The output pentode, DPT (V4), is provided with tone control by a condenser in series with a variable resistance between the anode and chassis, and is tone compensated by a condenser, C11, across the extra speaker sockets.

The extra speaker is filter fed between the anode and cathode. As usual, the speaker connections contain the make-before-break switch for disconnecting the internal speaker.

Mains equipment consists of H.F. chokes and smoothing chokes in each of the mains

leads, while the barretter lamp, type 251, and the speaker field are in series with the valve heater supply. Both mains leads are fused.

The valves are 16 v. .25 amp type.

**Special Notes.**

—The order of heater wiring is: barretter, speaker field, V4, V1, V2 and V3. The special modifications to the circuit when used with the radiogram are also shown on the circuit diagram.

The dial lamps are the 3.5 v. .3 amp. type. If this type does not have a satisfactory life the 6.4 volt .4 amp. 12 mm. MES type may be substituted. With the latter the illumination will not be so bright.



The D.C.5 by the G.E.C. is equivalent to the familiar A.V.C.5.

**Quick Tests.**—Between the terminals on the speaker transformer and chassis:—

- (1) Left hand (1) red and black, L.S. field.
- (2) Red, H.T. smoothed, 170 volts.
- (3) Green and black, speech coil.
- (4) Red and black, speech coil.
- (5) Orange and black, speech coil.
- (6) Orange, V4 anode, 145 volts.
- (7) Grey, L.S. field

**Removing Chassis.**—Remove the knobs by removing insulating composition from central holding screws and remove screws.

In the table model remove the two wooden battens underneath the cabinet, and then remove the four holding screws. In the console and radiogram models the screws are underneath the platforms.

**General Notes.**—In some models resistances of 80 ohms each may be found connected across the pilot lamp leads.

With the valves in position and cold the total resistance between the mains leads should be approximately 600 ohms.

In the table and console models all the (Continued on opposite page.)

**VALVE READINGS**

No signal; 200 and 250 volt mains.

Valve.	Type.	Electrode.	Volts.		M.A.
			200	250	200 250
1	DSB (5) ..	anode ..	150	190	1 1
		screen ..	55	75	
2	VDS (5) ..	anode ..	170	210	6 9
		screen ..	55	75	
3	DSB (5) ..	anode ..	* 65	75	.3 .35
		screen ..	65	85	
4	DPT (5) ..	anode ..	145	180	30 40
		aux. grid	170	210	

\*Very high values of resistances cause readings to be entirely misleading.