

MARCONIPHONE 561-564 TEN VALVE

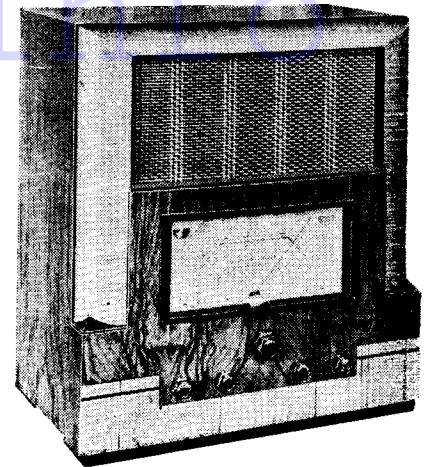

The Marconiphone 561 table model 10-valve set covers 5 wave ranges including one for the television sound channel. The 564 is a console.

CIRCUIT.—The aerial is coupled to V1, a pentode H.F. amplifier, via a set of transformer aerial coils. Arrangements are made for both an ordinary single wire aerial and one of the all-wave types using a transmission line.

V1 is tuned-primary H.F. transformer coupled to V2, a heptode frequency changer. V3, the separate oscillator of the frequency changing arrangements, is an H.F. pentode working in a Dow circuit. An additional reaction coil is included to ensure stable oscillation on the shortest wavelengths.

The signal, converted to the I.F., passes by an I.F. transformer of the controlled band width type to the first I.F. amplifier, V4, an H.F. pentode. A similar I.F. transformer feeds the second I.F. amplifier V5, also an H.F. pentode.

V5 is coupled to V6, a double diode valve, by an I.F. transformer of the fixed band width type. A tapping on the secondary is connected to the demodulating diode. The second diode of V3 provides a D.C. potential that is utilised for A.V.C.

Coupling arrangements to the grid of V7, an H.F. pentode connected to operate as a triode L.F. amplifier, include a manual volume control. The impulses that operate V7 are also utilised to feed the visual tuning indicator.

V7 is resistance-capacity transformer coupled to the push-pull amplifying valves V8 and V9. Across the primary of the coupling transformer is connected a bass tone control and a bass reduction circuit for S.W.2 and S.W.3 wavebands. Across the secondary is connected a tone control circuit consisting of a variable resistance and condenser.

A "degeneration" feed-back circuit that minimises harmonic distortion is formed by C47, R47, C48 and R42. A push-pull output transformer couples the output valves to the speaker. The secondary of the transformer is terminated in sockets to which wanderplugs from the internal speaker are connected so as to allow the speaker or chassis to be easily removed. Cathode bias is obtained from the voltage drop across R18 and R19 for the output valves.

Mains equipment consists of a mains transformer that is tapped for several

VALVE READINGS

No signal. Volume maximum. M.W. band. 225 volts, A.C. mains.

V.	Type.	Electrode.	Volts.	Ma.
1	(All Marconi) W63	Anode ..	220	3
		Screen ..	150	2
2	X64	Anode ..	230	2.5
		Screen ..	150	1
3	Z63	Anode ..	245	11
		Screen ..	245	11
4	W63	Anode ..	230	.7
		Screen ..	80	.2
5	W63	Anode ..	220	3
		Screen ..	80	.7
6	D63	Diodes only.	—	—
7	Z63	Anode ..	145	1.5
8	KT63	Anode ..	260	31
		Screen ..	275	5
9	KT63	Anode ..	260	31
		Screen ..	275	5
10	U50	Filament	290	—

voltages, a full wave rectifying valve, V10, electrolytic smoothing condensers and smoothing chokes.

Chassis Removal—Radio Chassis.—The cabinet has a false bottom that can be removed for minor repairs. The back is secured by four bolts. Remove the four control knobs (grub screw fixing) and also the two combined tuning knobs. The smaller of these is fixed by a grub screw. Removal of this enables the larger to be pulled away.

Remove the four fixing bolts and washers from underneath and the two connection plugs on the rear of the output chassis deck. The chassis can then be completely removed.

Output Chassis.—Completely remove the four fixing bolts and washers from the underside of the shelf. Remove the two

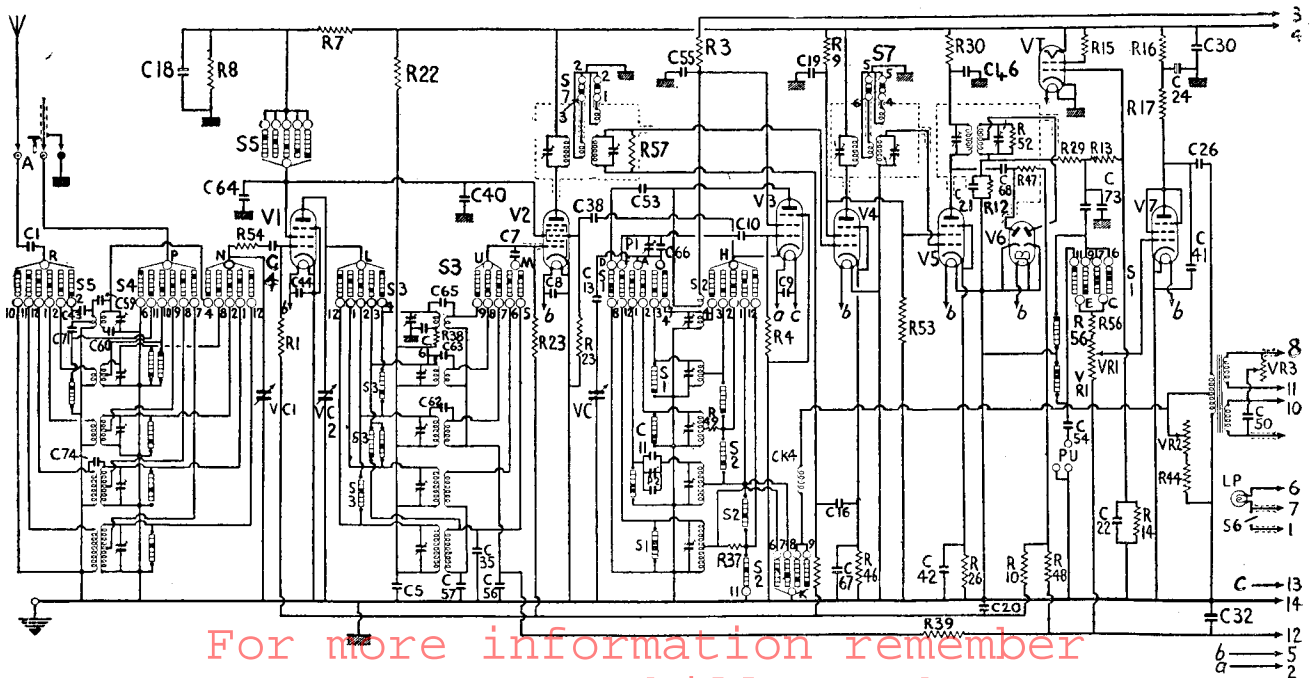

yellow speaker-connecting wander plugs from the front of chassis deck and also the two connection plugs from the rear of the chassis deck (if the radio chassis is still in position). The output chassis can then be removed.

Special Notes.—A single one-amp. fuse of the cartridge type is connected in the main H.T. lead of the receiver and is located at the rear of the output chassis.

A mains aerial socket at the rear of the output chassis is connected by a flex lead to the ordinary aerial socket when in use.

Sockets at the rear of the output chassis provide for external speaker. The receiver will operate up to four, providing the impedances are not lower than 5 ohms. The switch on the rear of the output chassis enables the external speakers to be operated either separately or in conjunction with the internal speaker.

Sockets are provided at the rear of the radio chassis for connecting a high resistance pick-up.

The single dial light is rated at 230 volts

Marconi 561 on Test

MODEL 561.—Standard model, 195-255 volts, 50-100 cycle A.C. mains. Price 24 gns.

DESCRIPTION.—Five-band, ten-valve, including rectifier, super-het table model.

FEATURES.—Full-vision scale marked in metres and station names. Concentric tuning with vernier dial. Controls for combined bass control and master switch, volume, combined tone and high-fidelity switch, and wave selection operating a rotating disc marked as to waveband. Visual tuning indicator. Sockets for external speaker and pick-up. Switch for internal speaker.

LOADING.—120 watts.

Sensitivity and Selectivity

ULTRA SHORT WAVES (4.85-12 metres).—Television sound was receivable at about 30 miles. Drift noticeable until set is thoroughly warm.

SHORT WAVES (11.3-34 and 34-107 metres).—Excellent gain and selectivity. Very easy handling and no drift. Many distant stations well received during day and night.

MEDIUM WAVES (195-575 metres).—A high degree of selectivity and powerful gain. Local station spread on adjacent channels only. Gain very even over waveband.

LONG WAVES (725-2,000 metres).—Performance similar to medium waves. Deutschlandsender received with only slight side splash. Ample reserve power.

Acoustic Output

Undistorted volume available is more than ample for an ordinary room. With the controls at maximum fidelity the balance is exceptionally nice and free from colouration. Top response is good and attack is very clean.

15 watts, is fitted with a bayonet-type base and located at the rear of the wavelength dial.

Certain models may be found to incorporate, in place of the two 100-ohms resistances in series (R18 and R19), two 500-ohms resistances in parallel for bias purposes. Also R53 may be omitted and R9 increased to 150,000 ohms.

The following components are inside the various coil screens: R57 is inside I.F.T.1; R12, R47, R52, C21 and C68 in I.F.T.3; R37 and R49 in O.2; C63 in H.1; C69, C11 and C62 in H.2; and C74 in A.1. R15 is across the V1 valve holder.

Fixed condensers are connected across the heaters of V1, V2 and V3 for by-pass purposes.

(Continued on page 24.)

EXACT replacement condensers for the 561 available from A. H. Hunt, Ltd., are: for C31 or C58, 3,058, 9s. 6d.; for C33, 3,056, 7s. 6d.; for C32, 1,807, 2s. 3d.; and for the unit containing C18 and C24, 3,857, 7s. 6d

CONDENSERS

C.	Purpose.	Mfds.
1	Series aerial00005
4	V1 grid isolating0001
5	V1 anode decoupling ..	.1
7	V2 M.W. and L.W. grid isolating0001
8	V2 heater bypass0023
9	V3 heater bypass0023
10	Oscillator grid0005
11	M.W. fixed trimmer0005
13	Oscillator tracking condenser0035
16	V4 A.V.C. decoupling ..	.023
18	V1 screen decoupling ..	.1
19	V4 and V5 screen decoupling ..	.1
20	A.V.C. line decoupling ..	.023
21	H.F. bypass0001
22	V1 grid, decoupling001
23	L.F. coupling01
24	V7 anode decoupling1
26	L.F. coupling023
30	H.T. line bypass1
32	V7 cathode bias shunt ..	.25
35	L.W. grid H.F. transformer grid shunt0001
38	Oscillator injection coupling ..	.0001
40	V2 screen decoupling0023
41	H.F. bypass0005
42	V5 cathode bias shunt1
43	S.W.3 aerial coupling000035
44	V1 heater bypass0023
46	V5 anode decoupling1
50	Tone control001
53	Anode coupling0023
54	Pick-up coupling05
55	Screen decoupling0023
56	V2 bias decoupling1
57	V2 L.W. grid circuit decoupling1
59	S.W.3 top aerial coupling ..	.00001
60	S.W.3 aerial padder0023
62	S.W.1 top coupling000005
63	S.W.2 top coupling000035
64	V1 screen decoupling S.W. ..	.0023
65	S.W.3 top coupling00001
66	L.W. fixed padder00015
67	V4 cathode bias shunt1
68	A.V.C. diode coupling000035
69	M.W. fixed padder000023
71	S.W.3 aerial00005
73	M.F. by-pass0001
74	M.W. top aerial coupling ..	.00001

OUTPUT CHASSIS.

31	H.T. line smoothing (second) ..	.32
33	H.T. smoothing16
47	Negative feed back0005
48	Negative feed back0005
58	Main H.T. line smoothing32
70	Mains aerial00035

RESISTANCES

R.	Purpose.	Ohms.
1	V1 A.V.C. decoupling .. .	1 meg.
2	V2 A.V.C. feed .. .	2.3 meg.
3	V3 screen decoupling .. .	2,300
4	V3 grid leak .. .	50,000
5	V4 A.V.C. decoupling .. .	100,000
6	Leak .. .	100,000
7	V1, V2 screen potr. (part) ..	3,200
8	V1, V2 screen potr. (part) ..	6,000
9	V4, V5 screen potr. (part) ..	35,000
10	A.V.C. line decoupling .. .	750,000
11	— .. .	50,000
12	Demond. diode load .. .	350,000
13	V2 grid potr. (part) .. .	2.3 meg.
14	V2 grid potr. (part) .. .	2.3 meg.
15	V1 anode feed .. .	1 meg.
16	V7 anode decoupling .. .	10,000
17	V7 anode load .. .	50,000
22	V1 anode decoupling .. .	2,300
23	Mixing valve grid leak .. .	50,000
26	V5 cathode bias .. .	500
29	H.F. stopper .. .	230,000
30	V5 anode decoupling .. .	2,300
37	L.W. regeneration modifier ..	1,500
38	S.W.3 anode decoupling .. .	1,000
39	S.W.1 bias decoupling .. .	23,000
44	Tone control .. .	1,000
46	V4 cathode bias .. .	5,000
47	A.V.C. diode load (part) .. .	230,000
48	A.V.C. diode load (part) .. .	500,000
49	S.W.1 regeneration modifier ..	150
52	I.F.T3 secondary shunt .. .	100,000
53	V4 and V5 screen potr. (part) ..	23,000
54	H.F. stabiliser .. .	6
56	VR1 series .. .	5,000
57	I.F.T1 secondary shunt .. .	150,000
VR1	Volume control .. .	1 meg.
VR2	Bass tone control .. .	50,000
VR3	Tone control .. .	1 meg.

OUTPUT CHASSIS.

18	Bias series resistors .. .	100
19	Bias series resistors .. .	100
24	V7 bias potr. (part) .. .	50,000
25	V7 bias potr. (part) .. .	230,000
40	Negative feed back .. .	150,000
41	Feed back injection .. .	10,000
42	Negative feed back .. .	10,000
43	Feed back injection .. .	150,000
45	External L.S. shunt .. .	50
CK1	Smoothing choke .. .	1,200
CK2	Smoothing choke .. .	257

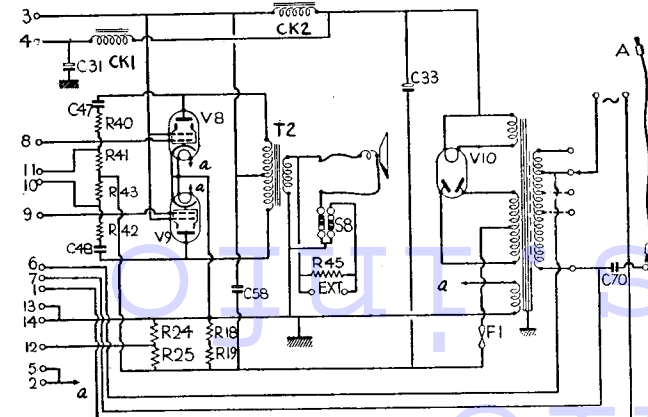

The 561 circuit and switch diagrams. Switch positions, top to bottom are: Gram., L.W., M.W., S.W.1, 2 and 3.

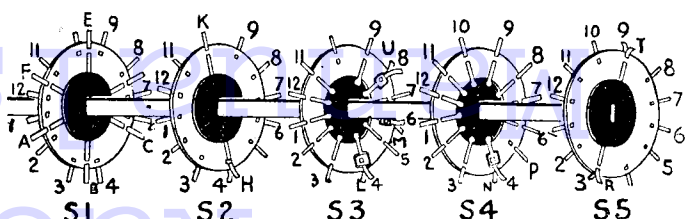

Marconi 561 Alignment

(Continued from page 23.)

I.F. Circuits.—Connect an output meter to the external L.S. sockets or across the primary of the speaker transformer. Switch set to M.W., set gang half way and short the grid of V3 to chassis. Set volume control to maximum, bass control fully anti-clockwise and tone control as far anti-clockwise as possible without switching to high fidelity.

Connect a modulated oscillator between top grid cap of V5 (leaving set connection "made") and chassis. Only feed sufficient input from the oscillator to obtain definite peaks in the output meter, so as to render the A.V.C. inoperative.

Tune the oscillator to 465 kc. and adjust T3A and T4A (third I.F.T.) for maximum.

Connect oscillator between top grid cap of V2 (leaving set connection "made") and chassis and adjust T1, T2, T3 and T4 for maximum.

Signal Circuits.—The scale pointer should be horizontal at both maximum and minimum of the gang and line up with the marks on the scale. Connect the service oscillator to aerial and earth sockets. Only feed sufficient input from the oscillator to obtain definite peaks on the output meter.

Long Waves.—Set gang to minimum, tune oscillator to 725 metres (413.8 kc.) and adjust T5, T6 and T7 in that order for maximum.

Tune set and oscillator to 1,900 metres

oscillator to 11.3 metres (26.5 mc.), and adjust T14 for maximum.

Tune set and oscillator to 30 metres (10 mc.) and adjust the spacing of the end turns of L22 for maximum.

Set gang to minimum, tune oscillator to 11.3 metres and adjust T15 and T16 for maximum.

Repeat operations until no further improvement is noticed.

S.W.3.—Tune set and oscillator to 5.5 metres

(54.5 mc.) and adjust T17, T18 and T19 in that order for maximum, using the peak obtained with T17 at the greater capacity. If the noise to signal ratio is excessive turn down volume control and increase input from oscillator.

Set oscillator to 9 metres (33.3 mc.) and tune in on set. If scale calibration is more than .25 metres out, then trim L24 by altering the point at which the crossed soldered leads connect and resolder. (This operation is only necessary when L24 is replaced or repaired.) Adjust L5 and L14 for maximum.

Repeat both operations until no further improvement is noticed.

Make certain that the correct peak of T17 is used by injecting a fairly strong signal and noting that the image of the signal is obtained at a lower point in wavelength than the signal itself.

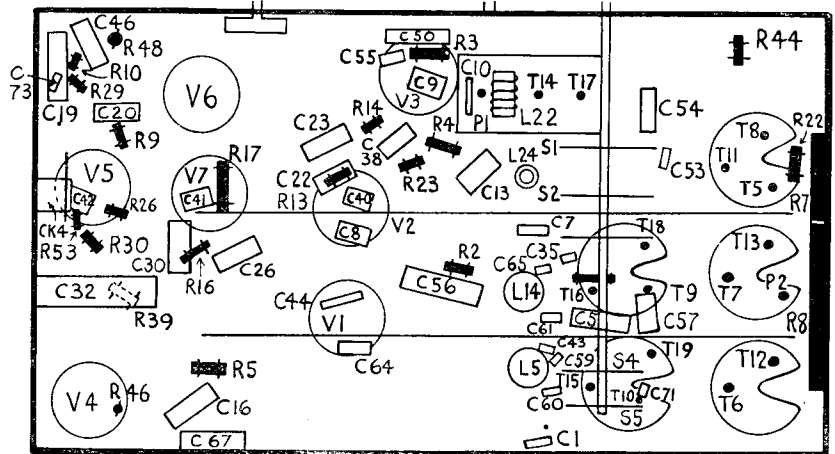

Above and below are the underside and top layout diagrams of the Marconiphone 561 main chassis. Corresponding diagrams of the output chassis are on the left.

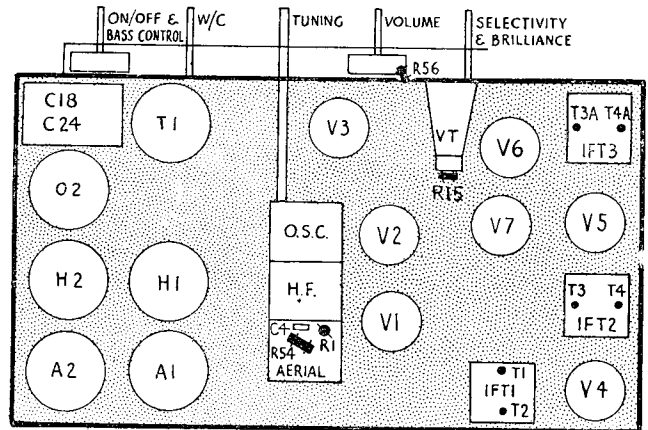
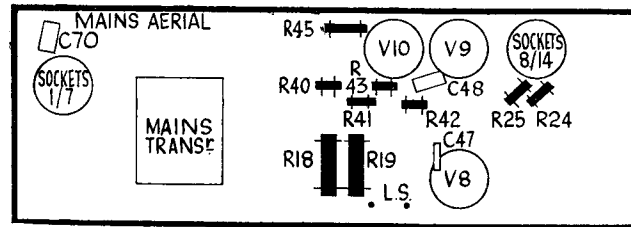
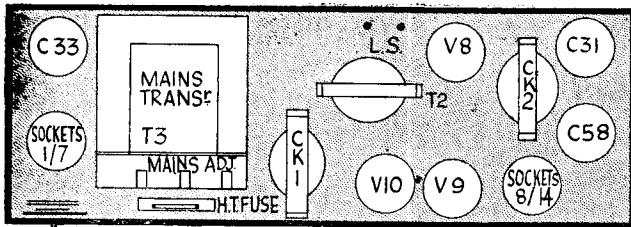

(157.9 kc.) and adjust P1 for maximum, simultaneously rocking the gang.

Repeat both operations until no further improvement is noticed.

Medium Waves.—Set gang to minimum, tune oscillator to 195 metres (1,538 kc.), and adjust T8, T9 and T10 in that order for maximum.

Tune and set oscillator to 530 metres (566 kc.) and adjust P2 for maximum, simultaneously rocking the gang.

Repeat both operations.

Short Waves.—S.W.1.—Tune set and oscillator to 35.2 metres (8,511 kc.) (this as marked with a spot on the dial) and adjust T11, T12, and T13 in that order for maximum. If noise signal ratio is excessive, turn down the volume control of the receiver and increase input from oscillator.

S.W.2.—Set gang to minimum, tune

the receiver. Feed only sufficient input to obtain definite peaks in the output meter, so as to render the A.V.C. inoperative.

Medium Waves.—Tune the set and oscillator to 214 metres (1,400 kc.) and adjust T1 then T2 and T3 for maximum response.

Tune the set and oscillator to 500 metres (600 kc.) and adjust P1 (the nut of the padding condenser) for maximum response, simultaneously rocking the gang to ensure optimum results.

Repeat until no further improvement can be obtained.

Long Waves.—Tune the set and oscillator to 1,200 metres (250 kc.) and adjust

T4 then T5 and T6 for maximum response.

Tune the set and oscillator to 1,714 (175 kc.) and adjust P2 (the screw of the padding condenser) for maximum response simultaneously rocking the gang to ensure optimum results.

Repeat the above operations until no further improvement is obtained.

Short Waves.—Tune the set and oscillator to 17.6 metres (1.7 mcs.) and adjust T7 and then T8 for maximum response.

Tune the set and oscillator to 50 metres (6 mcs.) and check the calibration. If calibration is very much out then compensate with T7 and then adjust T8 on a 17.6 metre oscillator signal.

K.-B. 632 Alignment Notes

(Continued from page 3.)