

MARCONIPHONE T18DA

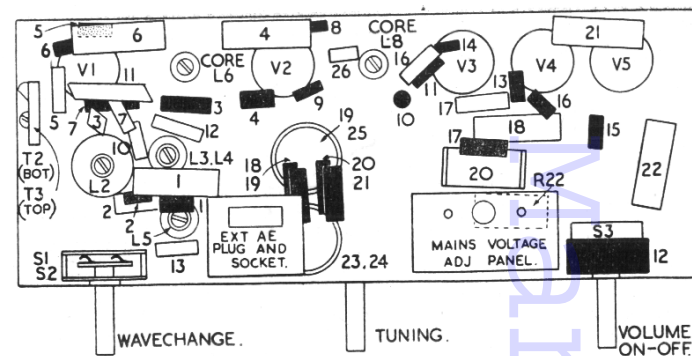

R	23, 24, 25, 26.	6	7	5	2	1	3	4	8	18, 19	9	20	21	10	11	14	17	13	16	15	12						
C				14	15	19	25	8	9					5	3	11	6	12			26	19, 25	16	17	18	21	22
L				12	9	10	11	7	1					2	7	10	13	1			23, 24			20			

Transportable five-valve two-waveband superhet fitted with internal frame aerial. Sockets provided for use with an external aerial. Suitable for 195 to 255V DC and 25-100c/s AC. Cream moulded plastic cabinet. Marketed by Marconiphone Co., Ltd., Hayes, Middlesex.

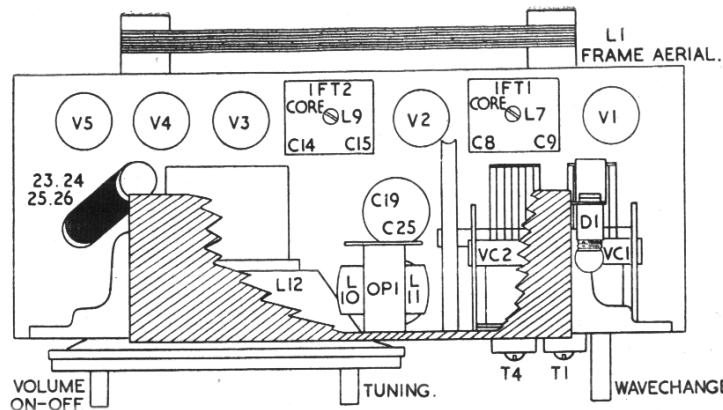
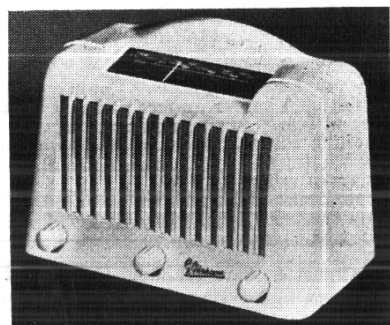
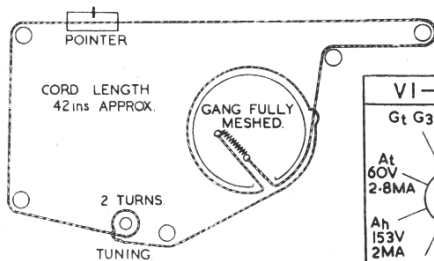

V1 - X I42	V2 - WD I42	V3 - WD I42	V4 - NI I42	V5 - U I42	DIAL LAMP
<p>Gt G3 G2 G4 67V 1.9MA At 60V 2.8MA G1 K Ah 153V 2MA H H</p>	<p>K G3 G2 67V 1MA G1 D A 153V 2.5MA H H K G3</p>	<p>K G3 G2 39V 0.35MA G1 D A 39V 1MA H H K G3 1-IV</p>	<p>G2 153V 6MA G1 KG3 A 213V 33MA H H K G3 9-IV</p>	<p>A 225V RMS H H K 225V 55MA</p>	<p>6.2V 22A</p>

RESISTORS

R	Ohms	W
1	1M	...
2	22K	...
3	22K	...
4	47K	...
5	470K	...
6	33K	...
7	33K	...
8	1.5M	...
9	1.5M	...
10	100K	...
11	470K	...
12	2M Potr. with DP switch	...
13	100K	...
14	1K	...
15	470K	...
16	10K	...
17	220	...
18	6.8K	...

R	Ohms	W
19	6.8K	...
20	220	...
21	220	...
22	100 WW	2W
23	50 WW	Mains
24	80 WW	Dropper
25	150 WW	Resistor
26	950 WW	...

CAPACITORS

C	Capacity	Type
1	.01 Tubular	1000V
2	.005	500V
3	15pF	Silver Mica
4	.05 Tubular	1000V
5	100pF	Ceramic
6	.05	1000V
7	100pF	Ceramic
8	100nF	Silver Mica
9	100pF	"
10	500pF	Mica
11	450pF	Silver Mica
12	200pF	"
13	100pF	Tubular Ceramic
14	100pF	Silver Mica
15	180pF	"
16	100pF	Tubular Ceramic
17	500pF	Mica
18	.02 Tubular	1000V
19	16 Electrolytic	350V 12V
20	.25	12V
21	.02 Tubular	1000V
22	.01	1000V
23	16 Electrolytic	350V
24	16	350V
25	16	350V
26	50pF	Tubular Ceramic

INDUCTORS

L	Ohms
1	3
2	11
3	1
4	2.5
5	5.5
6	7.5
7	7.5
8	7.5
9	5
10	160
11	.5
12	3.2

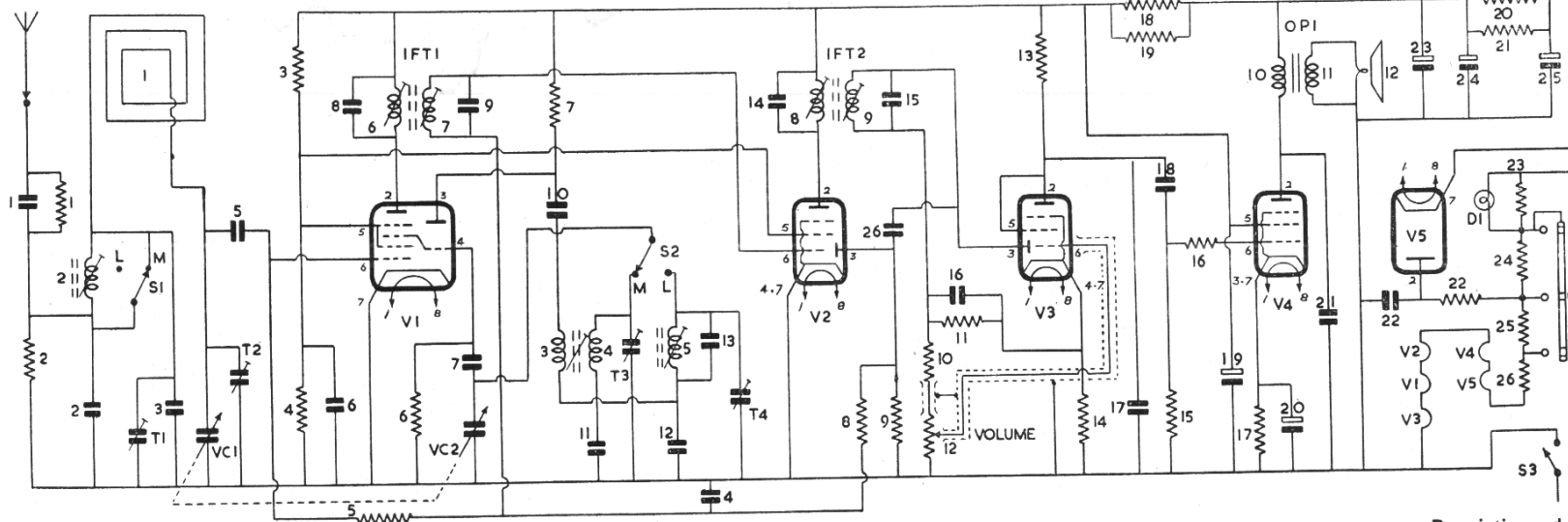

Description and alignment notes, see page 23.

MARCONIPHONE T18DA

Continued from page 20

AERIAL. The receiver is fitted with an MW frame aerial L1 with a series LW loading coil L2. A socket is provided underneath chassis for the use of an external aerial when desired. The external aerial is fed through isolating capacitor C1 shunted by R1 to R2, C2 in bottom end of L2.

The frame L1 and loading coil L2 are connected in series across aerial tuning capacitor VC1 and coupled by C5 to triode-hexode frequency-changer V1. On MW band L2 is shorted out by S1 and L1 is tuned by VC1 and trimmed by T2. On LW band S1 is open and L2 trimmed by T1, C3 is placed in circuit with L1 and tuned by VC1.

AVC decoupled by R8, C4 is fed by R5 to V1. Cathode is at chassis potential. Screen voltage is obtained from potential divider R3, R4 decoupled by C6. Primary L6, C8 of IFT1 is in the hexode anode circuit.

Oscillator is connected in a tuned-grid shunt-fed circuit. The grid coils L4 (MW), L5 (LW) which are trimmed by T3, T4 and padded by C11, C12 respectively, are switched by S2 to oscillator tuning capacitor VC2, and coupled by C7 to oscillator grid (gt) of V1. Automatic bias for grid is developed on C7 with R6 as leak resistor.

Anode reaction voltages are obtained inductively from L3 on MW and capacitively from across padder C12 on LW, and are fed by C10 to oscillator anode of V1 of which R7 is the load resistor.

IF amplifier operates at 465kc/s. Secondary L7 C9 of IFT1 feeds signal and AVC voltages decoupled by R8, C4 to IF amplifier V2. Cathode and suppressor are strapped together and earthed to chassis. Screen voltage is obtained from potential divider R3, R4 and is decoupled by C6. Primary L8, C14 of IFT2 is in the anode circuit.

Signal Rectifier. Secondary L9, C15 of IFT2 feeds signal to diode anode of V3. R11 is diode load and C16 reservoir capacitor.

AF amplifier is pentode section of V3 operated as a triode its screen being strapped to anode and suppressor connected to cathode.

Rectified signal developed across diode load R11 is fed through R10 to the volume control R12 and thence to gl of V3. R10 with self-capacity of screened lead form an IF filter. Cathode bias is provided by R14. Anode load is R13 with C17 as RF bypass capacitor.

AVC. Signal on secondary L9 of IFT2 is fed by C26 to diode anode of V2. R9 is the diode load and R8, C4 give decoupling to AVC line to V1, V2.

Output stage. C18 feeds signal through stopper resistor R16 to pentode output amplifier V4. R15 is its grid resistor and R17 decoupled by C20 provides cathode bias. Screen voltage is obtained from R18, R19 decoupled by C19. Primary L10 of output matching transformer OP1 is in the anode. C10 is a tone correction capacitor. Secondary L11 of OP1 feeds signal to a 5 in. PM speaker L12.

HT is provided on AC mains by an indirectly heated half-wave rectifier V5. Its anode voltage is obtained from the mains through current limiter R22 and tapped dropper resistor formed by R23, R24, R25. The dial lamp is shunted across R23. Resistance-capacity smoothing is given by R20, R21, C23, C24, C25. Additional smoothing and voltage dropping to earlier stages is given by R18,

R19, C19. Modulation hum is eliminated by C22. Reservoir capacitor C25 should be rated to handle 125mA ripple current.

Heaters of V1 to V5 are series connected and obtain their current from the mains through R23 and dropper resistors R24, R25, R26. On 236-255V all the droppers are in circuit. On 216-235V and 195-215V the voltage changing plug short circuits R24 and R24, R25 respectively.

S3 which is ganged to volume control spindle is the ON/OFF switch.

Chassis removal. Undo the four screws securing panel to bottom of cabinet and remove panel. Remove the three push-on type control knobs.

Loosen the four chassis fixing screws (one at each corner of chassis). These screws are held captive on chassis by a small spring clip. Carefully withdraw chassis from cabinet.

TRIMMING INSTRUCTIONS

Apply signal as stated below	Tune Receiver to	Trim in order stated for max. output
(1) 465 kc/s to gl of VI, via .1 mF	Gang at Max. Capacity	Core L9, L8, L7, L6.
(2) With Gang at Max. Capacity check to see that dial pointer coincides with 2000 metre mark at end of scale.		
(3) 530 kc/s to AE Socket via dummy aerial	566 metres (end of scale)	Core L3/4
(4) 1.52 mc/s as above	197.7 metres	T3
(5) 1.304 mc/s as above	230 metres	T2, Repeat (3) (4) and (5)
(6) 150 kc/s as above	2000 metres	Core L5
(7) 335 kc/s as above	895.5 metres	T4
(8) 160 kc/s as above	1875 metres	Core L2
(9) 300 kc/s as above	1000 metres	T1, Repeat (6), (7), (8) and (9).

MOTOR-BOATING—WITHOUT HUM

ONE cannot depend on increased hum as an indication that the smoothing capacitor has gone "low." I had in two receivers which were "motor-boating" and, as the hum level was normal, I assumed the oscillation to be HF in origin.

When I finally found that lack of full LF decoupling was the cause, I decided that in such cases in future I would first check the smoother. If this is down in capacity, voltages may be a little low, but not enough to provide a real pointer and, as I have found, hum may not be noticeably increased.—E.G.C.

SERVICE CHART MANUAL

Service charts are one of the engineer's most profitable investments. They become increasingly valuable as they get older. Today, for 6s. you can get 44 charts, each of which will save you that sum many times over in the years ahead. They are in Volumes 2 and 3 of SERVICE CHART MANUAL, now available from 6 Catherine Street, London, WC2.

MASTERADIO T612L, T612M

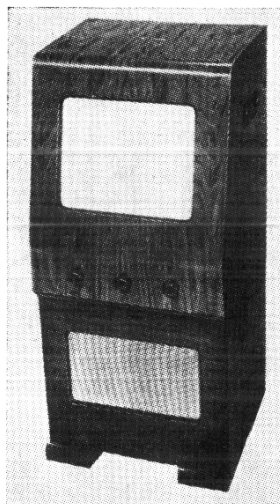

Seventeen-valve television receiver fitted with a 12-in. CRT giving a 10 by 7½-in. picture. Walnut veneered console cabinet. Suitable for 200-250V 50c/s supplies. Model T612L is for London frequencies and T612M for Birmingham frequencies. Manufactured by Masteradio, Ltd., 319-321, Euston Road, London, NW1.

THE receiver uses TRF circuits with permeability tuned inductances operating on the lower sideband of vision carrier. Sound channel is fitted with noise suppressor and EHT is developed from line flyback pulses. Model T612L is for London area and Model T612M for Midlands. When fitted with preamplifier for use outside the normal reception areas the models become T612LP and T612MP respectively.

Aerial signal is fed by an 80 ohm co-axial feeder through isolating capacitors C1, C2 to L1 and coupled by L2 to first RF amplifier V1.

Vision channel consists of three RF amplifiers V1 to V3, signal rectifier V4A, and video output amplifier V5. V1 is resistance-capacity coupled by R4, C6 to tuned grid coil L3 of V2. Signal developed across tuned coil L5 in anode V2 is capacity fed by C11 to grid of V3, which is then resistance-capacity coupled by R10, C16 to tuned coil L7 in signal rectifier V4A anode circuit.

The tuned circuits are staggered to give an overall bandwidth of approximately 3mc/s at 6dB down. Aerial damping together with shunt effect of R4, C6 across L3 ensures that bandwidth of V1 is sufficient to cover both sound and vision frequencies. Gain of V1, V2 is adjusted by R2, the Contrast control in the common cathode circuit.

Sound signal rejection is given by L4, C7 in grid and L6, C12 in anode circuit of V2.

Rectified signal developed across R11, R12 is DC coupled to video output amplifier V5, the output of which is DC coupled through RF choke L14 to cathode of CRT. L10, L11 are grid and L12, L13 anode peaking coils and R63 limits DC potential between heater and cathode of CRT.

Sound channel. Sound signal of 41.5mc/s, which is amplified with vision by V1, is tapped from L4, inductively coupled to grid tuned coil L3 of V2, and fed to first sound RF amplifier V6. Tuned anode with capacity coupling is used between V6 and second sound RF amplifier V7 and also between V7 and signal rectifier diode of V8.

The gain of V6 is controlled by variation of its cathode bias by R2 the contrast control. Rectified audio signal developed across R48 is fed by C49 to Volume control R52 and thence through stopper R51 to grid of triode section of V8 for amplification, after which it is fed by C50 through noise suppressor diode V4B and coupled by C53 to tetrode output amplifier V9, the output of which is transformer coupled by OP1 to an 8-in. PM speaker L21.

Noise suppressor. Diode anode of V4B is connected to HT line through R56 and its cathode down to chassis through R55, R54, R53. It conducts and allows the audio signal fed to its cathode by C50 to be passed on to V9. The time constant of R56, C52 is such that the voltage on C52 follows that of the audio signal. When a large amplitude high frequency interference pulse appears with the signal then cathode of V4B is driven more positive than its anode—the anode voltage being unable to change rapidly due to the comparatively long time constant of R56, C52. Thus, during an interference pulse, V4B is cut-off and no signal is passed to output amplifier V9.

To prevent clipping, due to large amplitude transients, a small amount of the audio signal, obtained from junction of R59, C57, the tone correction network across primary L19 of OP1 in anode of V9, is fed by C54 to second diode anode of V8, rectified and applied as a negative bias through R54 to cathode of noise suppressor V4B.

Sync separator. Signal at anode of video amplifier V5 is fed by R17, C22 to grid of sync separator V11. The positive sync pulses drive V11 into grid current and produce across R20 a steady negative bias. The bias is sufficient to place the negative picture signal below cut-off and only the positive sync pulses appear in the anode of V11.

Sync amplifier. Frame sync pulses at anode V11 are fed by C25 to grid of triode V12A, amplified and then fed through C29 to anode of frame oscillator V13A. Line sync pulses are fed by C27 to triode V12B, amplified and then fed through C28 to grid of line oscillator V13B.

Frame oscillator is triode V13A operated as a grid-blocking oscillator with anode to grid transformer back-coupling by FT1. Frequency is determined by time constant of R31, C30. Scan voltage is developed on C31 with R32 giving waveform correction. Adjustment of grid bias by R30 gives Frame Hold.

Frame amplifier. Scan voltage is fed by C32 through stopper R38 to beam-tetrode V15. Scanning waveform is developed across anode load R36 and fed by C33 to frame deflector coils L17, L18 on neck of CRT. R37 introduces negative feedback to screen (g2) to improve linearity. Variation of the HT across V15 by R41 gives control of Frame Height.