

MARCONIPHONE 859 AC-DC FIVE

Four valve, plus rectifier, three waveband manual tuned table superhet for AC or DC supplies, 200-250 volts, 25-60 cycles, price 11½ gns. Similar chassis in H.M.V. model 654.

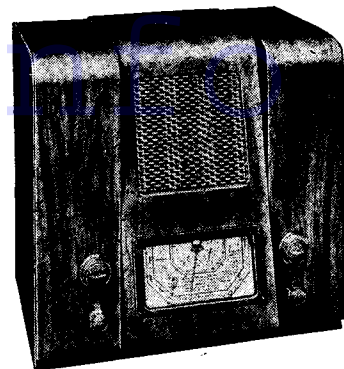

CIRCUIT OUTLINE

USE is made of a special network in the aerial circuit which simplifies switching. The three windings are coupled to tuned circuits which are selected by a switch in the normal manner. These circuits form the input to the frequency changer, V1, a heptode.

This valve has a conventional oscillator section. The intermediate frequency transformers are trimmer tuned, the first being in the anode circuit of V1. The secondary works into the grid of V2, the intermediate amplifier. The steady bias for this stage is derived from a series bias resistance instead of the more general cathode resistor.

V3 is a double diode triode and derives its input from the secondary of IFT2. One diode is used for demodulation and the other for AVC. The series bias circuit provides the delay voltage for the AVC diode and also the bias for the triode amplifier.

Signal voltages are taken from the diode

load through a simple filter to the volume control, and this forms the input to the triode section.

Resistance capacity coupling is used between the triode and the output tetrode, V4. This is fitted with a feedback circuit between anode and grid, the resistive element forming the tone control.

Power supply is taken from the mains through a strapped rectifier, V5. The mains input circuit includes a filter. The valve heaters are run in series through a volt-dropping resistance fitted with the usual adjustment tappings.

CONSTRUCTIONAL FEATURES

THERE should be little difficulty in identifying any of the components in the set, as there are no hidden sections. It will be noticed that all the electrolytic condensers, with the exception of one, are in a single case, and the connecting leads

are colour coded. The coding is marked on the condenser case.

As the set is a universal model care must be exercised in taking any measurements to guard against the possibility of shock or short circuits.

The voltage adjustment is carried out by means of a special tapped-resistance assembly wound on a mica strip. The assembly is a separate unit bolted to the side of the chassis. This unit carries the

(Continued on page 33)

VALVE READINGS

V.	Type.	Electrode.	Volts.	Ma.
(All Marconi).				
1	X63	Anode	180	2
		Screen	65	1.5
		Osc. anode	140	3
2	KTW63	Anode	180	7
		Screen	90	1.5
3	DH 63	Anode	120	.5
4	KT32	Anode	120	60
		Screen	125	4
5	U31	Cathode	188	—
Pilot lamps. MES frosted tubular				6-8

RESISTANCES

	Ohms.	
1	V1 osc. grid	100,000
2	Osc. anode decouple	3,500
3	Osc. anode load	10,000
4	V2 screen pot. (part)	5,000
5	V2 screen pot. (part)	15,000
6	Signal diode load	500,000
7	HF stopper	230,000
9	V3 anode load	750,000
10	AVC diode load (part)	1 meg.
11	AVC diode load (part)	500,000
12	AVC diode load (part)	2.3 meg.
15	V4 grid lead	350,000
17	Series bias	23
20	Het. volt control	150
23	V3 anode decouple	35,000
24	Sub-HT line decouple	5,000
25	V4 grid stopper	50,000
26	V4 cathode bias	100
27	Bias decouple	100,000
28	V4 anode decouple	1,000
30	Mains resistance (part)	62
31	Mains resistance (part)	370
32	Mains resistance (part)	64
33	V1 screen decouple	75,000
34	Volume control	2 meg.
35	Tone control	2 meg.

WINDINGS

L	Ohms	Range	Where measured
1+2+5	44	SW	C4+C5 and chassis.
1+2+			
4+5.	10	MW	C4+C5 and chassis.
(L1, 9.5 ohms; L2, 33 ohms; L4, very low; L5, 1.6 ohms.)			
3	Very low.	SW	V1 grid and C3.
6	2	MW	V1 grid and C3.
7	9	LW	V1 grid and C3
8	Very low.	SW	C6 and C9.
9	2.8	MW	C6 and C9.

Right, the top layout diagram of the Marconi chassis showing the positions of the I.F. trimmers and adjustable coils.

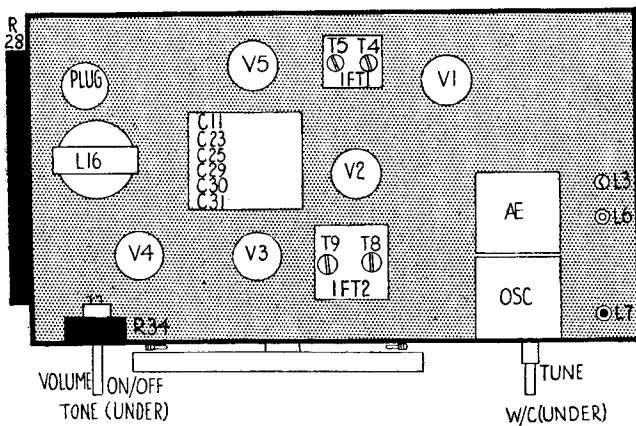

Left, H.F. and L.F. portions of the receiver are sectionalised. Resistances are indicated in solid black, condensers in outline.

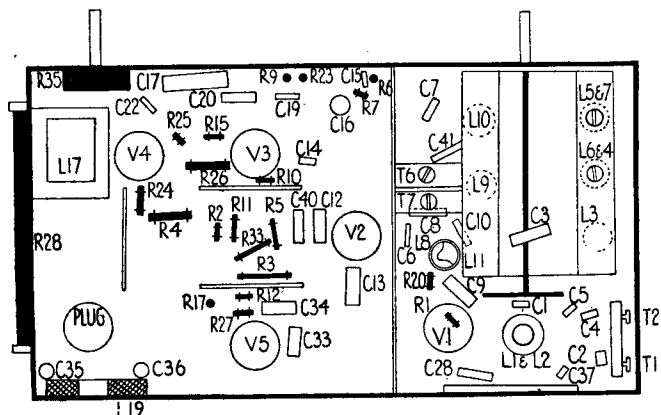

10-MINUTE FAULT-FINDER

MARCONI 859

Power Test.—The object of this test is to make sure general operating conditions are correct and to reveal any major H.T. circuit faults. As the smoothing choke is not in the main total H.T. line, the power test is taken across R17, the series bias resistance.

No external tests are available, as the set is a universal model with all live points shielded. The italic letters refer to the test points shown in the circuit diagram. *E* refers to chassis, not the actual earth connection.

Voltage : *A-E*, 1.8 volts.
Resistance : *A-E*, 23 ohms.
Total feed is 1.8 v. + 23 ohms = 79 ma.
Output Stage, V4.—Inject 2 volts A.F. between V4 grid and chassis. If defective, check :—
Voltages : *D-E*, 120; *F-E*, 125.

Resistances : *B-D*, 1,146; *F-C*, 5,000; *G-E*, 355,000 ohms.

A.F. Stage, V3.—Inject 0.5 volt A.F. V3 grid and chassis. If defective, check :—
Voltage : *H-E*, 120.

Resistances : *H-C*, 100,000 ohms; *I-E*, 2.1 megohms.

Demodulation Stage.—Inject very strong 465 kcs. signal at V2 anode. If defective, check :—
Resistances : *J-E*, 500,000; L15, 4 ohms.

I.F. Stage, V2.—Inject a 465 kcs. signal at V2 grid. If defective, trim T8, T9, and check :—
Voltages : *K-E*, 180; *L-E*, 90.
Resistances : *K-C*, 4; *L-C*, 10,000; *L-E*, 15,000 ohms.

Mixer Section, V1.—Inject 465 kcs. signal V1 anode. If defective, trim T5 and check :—
Resistances : L13, 4 ohms; *M-E*, 2.4 megohms.

Inject 465 signal V1 grid. If defective, trim T4 and check :—
Voltages : *N-E*, 180; *O-E*, 65.

Resistances : *N-C*, 4; *O-C*, 78,500 ohms.

Oscillator Section, V1.—Check voltage *P-E*, 140.
Resistances : *P-C*, 13,650; *Q-E*, 100,000 ohms.

Tune to local station and inject local station plus 465 kcs. at oscillator grid. Signals then show oscillator fault.

If no signals are obtained, test input circuits, switches and connections, for shorts or open circuits.

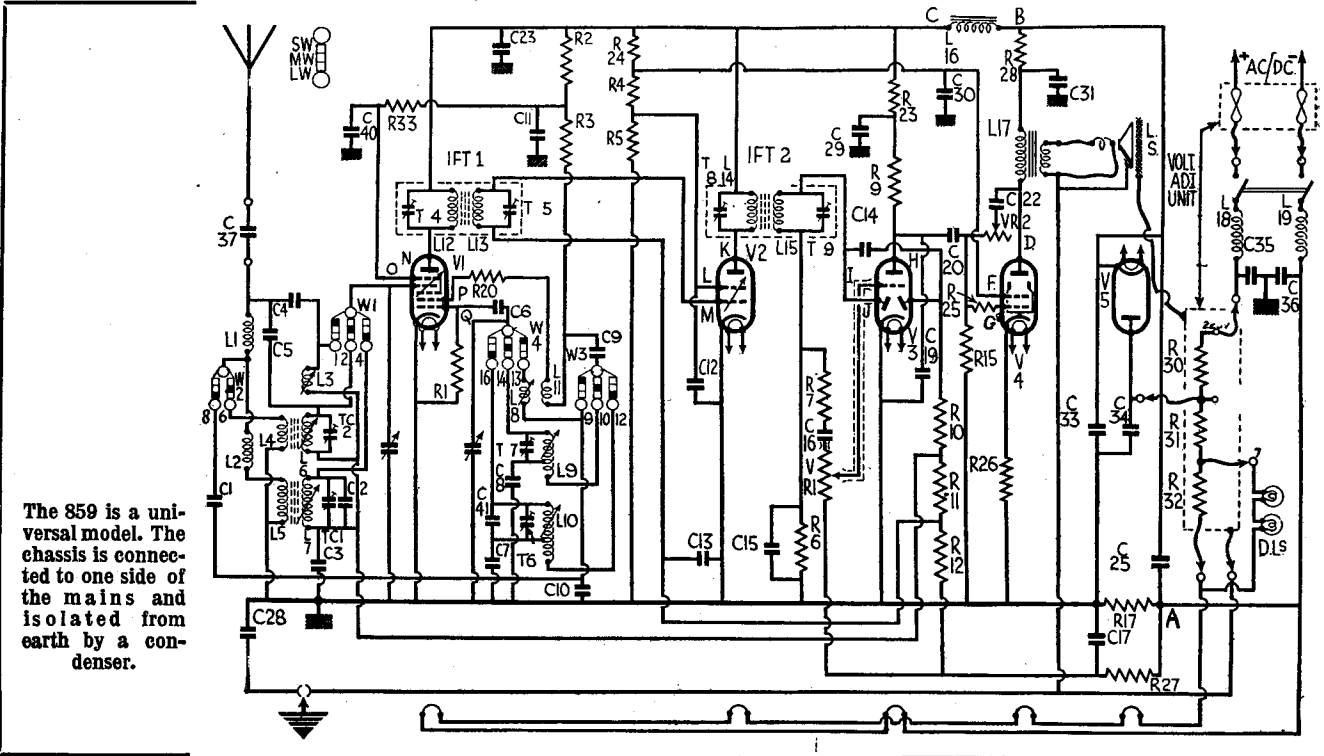

The 859 is a universal model. The chassis is connected to one side of the mains and isolated from earth by a condenser.

Windings (continued)			
10	3.6	LW	C6 and C9.
11	1.2	—	R3 and R20.
12	4	—	V1 anode and HT positive.
13	4	—	V2 grid and C13.
14	4	—	V2 anode and HT positive.
15	4	—	Signal diode and R6 + R7.
16	550	—	On tags.
17	146	—	V4 anode and C31 + R28
18	3	—	On tags.
19	3	—	On tags.

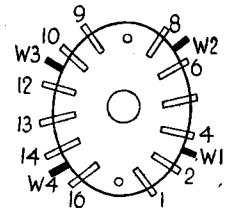

The single switch bank with wiper and contacts numbered as in the circuit.

Condensers (continued)			
7	LW fixed padder	..	.0003
8	MW fixed padder	..	.000175
9	Osc. anode coupling	..	.005
10	SW fixed padder	..	.005
11	Osc. anode decouple	..	.4
12	V2 screen decouple	..	.05
13	V2 AVC decouple	..	.05
14	AVC coupling	..	.000075
15	Diode load shunt	..	.0001
16	LF coupling	..	.001
17	Bias shunt	..	.50

Condensers (continued)			
19	V3 anode shunt	..	.00035
20	LF coupling	..	.023
22	Tone control	..	.0005
23	HT smoothing	..	8
25	HT smoothing	..	16
28	Chassis isolating	..	.01
29	V3 anode decouple	..	.1
30	Sub-HT line decouple	..	.4
31	V4 anode decouple	..	.32
33	HF shunt	..	.05
34	HF shunt	..	.05
35	Mains filter	..	.01
36	Mains filter	..	.01
37	Aerial coupling	..	.05
40	V1 screen decouple	..	.05
41	LW osc. fixed trimmer	..	.000175

CONDENSERS			
1	Neutralising	..	.00005
2	LW input fixed trimmer	..	.00005
3	V1 AVC decouple	..	.05
4	SW aerial coupling	..	.000015
5	MW top coupling	..	.0000023
6	Osc. grid	..	.0001

Replacement Condensers.
Exact replacement condensers are available from A. H. Hunt, Ltd., Garratt Lane, Wandsworth, London, S.W.18. For the block, C11 23, 25, 29, 30 and 31, there is unit 1,283, 18s. 6d., and for C17, unit 2,915, 1s. 9d.

Marconiphone 859 Five

(Continued from page 48)

voltage-adjustment strip and two fuses, in addition to a double-pole safety plug, and is connected to the chassis through a multiple plug and socket.

The greatest difficulty likely to be experienced with the set is in the matter of ganging. Particular care must be paid to the ganging instructions, as they involve the adjustment of cores for medium and long waves and the movement of a wire loop on the short waves.

A "spade" or inductance adjuster is used on the MW oscillator coil, for example. The adjustment of L6 and L7, the MW and LW input coils, is carried out through holes in the top of the chassis and really requires a special tool. The oscillator coils can be adjusted through holes in the coil screen underneath the chassis.

It is most important to realise that in none of the ganging operations is it necessary to rock the condenser gang, in fact, this must be particularly avoided.

The set includes provision for aerial connection and earthing through a special split socket now usual in universal sets. Extra speakers have to be fitted by soldering leads to the speech coil tags, which operate at a total impedance of 3.75 ohms.

Wave-change Switches.

All switching is carried out by a single wafer which carries twelve contacts and four wiper. The drawing shows how the wafer appears when viewed from the back of the chassis.

The wiper W1 controls the tuned input and W2 controls the aerial circuit on MW and LW.

The oscillator circuit is associated with W3 and W4, which respectively select the untuned and tuned portions of the oscillator coils for the three bands.

Chassis Removal.

Four bolts retain the chassis but before they can be unscrewed it is necessary to release two wooden strips which act as protection to live metal parts. These strips are held by two small wood screws.

Protection of the grub screws in the control knobs is also provided, and before the knobs can be removed it is necessary to scrape away the sealing compound.

The chassis can then be removed after unsoldering the two speaker leads. One speaker tag is earthed to the frame and the wire on this tag should go to the earthy lead (black) on resoldering.

Bolts retain the speaker itself and removal of this can be effected by releasing the bolts or unscrewing the sub-baffle.

Alignment

IF Circuits (Frequency 465 kc.)

Connect an output meter to the set and the generator to the grid of V1 and inject a signal of 465 kc.

Adjust T4, T5, T8 and T9 in that order for maximum, always using a low input below the value at which the AVC operates.

Medium Waves (195-580 metres).

Before trimming, check that the pointer spindle hole is concentric with the spindle and see that the scale is square in its frame. Turn the gang to maximum and check the alignment of the pointer with

the small black spot at the top right hand corner.

Tune the generator to 225 metres (1,333.3 kc.) and adjust the pointer to this position (shown on the scale by another black spot) and adjust T7 for maximum.

Tune set and generator to 530 metres (566 kc.) and adjust the spade inductance trimmer of L9.

Repeat these operations and re-check at 225 metres. Then adjust T2 for maximum at 225 metres.

Retune set and generator to 530 metres and adjust the upper core of L6 by means of the special tool or an insulating strip. Re-check at 225 metres.

Long Waves (1,000-2,000 metres).

Tune set and generator to 1,100 metres (272.7 kc.) and adjust T6 for resonance.

Tune set and generator to 1,900 metres (158 kc.).

Adjust L10 for resonance in a similar manner to that adopted for adjusting the MW coil.

Repeat the operation and re-check at 1,100 metres, adjusting T1 for maximum.

Tune set and oscillator to 1,900 metres and adjust hexagonal-headed screw core of L7 for maximum.

Tune set and generator to 1,400 metres (214.3 kc.) and adjust T1 for maximum.

Short Waves (13.8-50 metres.)

Connect generator to set through a 400-ohm series resistance and 100 ohm shunt dummy aerial and tune set and generator to 50 metres (6 mc.).

Adjust the loop in L8 for maximum, using an insulating strip to push the wire up and down.

Then adjust the loop in L3 in a similar manner.

TRUPHONIC MA5

(Continued from page 36)

active contacts are marked on our diagram for each of the four wafers.

The next wafer controls the pick-up and carries wiper W9 and W10. Finally there is the sixth wafer, which carries wiper for feedback and the pilot lamps.

Chassis Removal

Remove the four control knobs from the front of the panel; two are held by grub screws and two by spring clips. Pull out the six press button levers.

Withdraw the aerial and earth plugs and the multiple speaker plug from their appropriate sockets. Unscrew the extension speaker strip or unsolder the wires to it. Release the chassis retaining bolts.

Alignment

I.F. Circuits (frequency, 465 kcs.).

Connect output meter to the set, short circuit the oscillator gang and inject on the grid of V1 a signal of 465 kcs. from the generator. Progressively adjust the trimming cores of L14 to L11 in that order, using a low input.

Medium Waves (200 to 580 metres).

Connect the generator to the aerial socket through a dummy aerial, turn the gang to minimum and inject a signal of 1,500 kcs. and adjust T1 for maximum.

Tune set and generator to 1,400 kcs. and adjust T2 for maximum.

Tune set and generator to 550 kcs. and adjust P1 for maximum, simultaneously rocking the gang. Retune to 1,500 kcs.

and check T1, and repeat the ganging process until no further adjustment is necessary. Check the cover from 1,500 to 525 kcs.

Long Waves (1,000 to 2,000 metres).

First adjust T3 with the gang at minimum on 300 kcs. Adjust T4 when tuned to 290 kcs., and P2 at 160 kcs., rocking the gang as before.

Check the cover from 300 to 152 kcs.

Short Waves (15 to 50 metres).

Turn the condenser into mesh about 5 degrees and swing the generator round 17.6 mcs. This will give two signals.

Set the generator on the lowest frequency signal and adjust T5 for maximum output. Check at 6.5 mcs. and retrim.

The cover should be M.8 to 6 mcs.

Press Buttons

SLACKEN the cam release bolt on the end of the shaft adjacent to the bakelite drive wheel. This should release the cams. If it does not do so, the cams are sticking owing to the spring being tight. Slacken the spring by inserting a thin screwdriver between the cam affected and the spring.

Tune in the desired station manually and press down the lever on which it is desired to obtain the station.

See that the roller is in the dead centre part of the heart-shaped cam. Then tighten the locking-screw on the end of the shaft.

Should the cams fail to release, it may be due to the grub screws which hold

the drum for the indicator operating cord being too tight on the shaft. This, however, is very rare. If it is necessary to alter them it will mean setting up the indicator again.

KOLSTER BRANDES 735

(Continued from page 34)

Tune generator and set to 1,400 kcs. (214 metres). The receiver setting is indicated by a small dot on the scale. Trim T5 and T2 for maximum output.

Tune set and generator to 600 kcs. (500 metres) and adjust P1.

Recheck the trimming at 214 metres.

Long Waves (740-2,050 metres).

Tune set and generator to 300 kcs. (1,000 metres), and adjust T6 and T3 for maximum.

Tune set and generator to 175 kcs. (1,714 metres) and adjust P2. The 175 kcs. setting is denoted by another dot on the tuning scale.

Repeat the operations until the calibration is correct over the scale.

Short Waves (16.5-52 metres).

Tune set and generator to 17 mcs. (17.6 metres), where a dot will be found on the scale, and adjust T4 for resonance.

Two positions will be found, the correct one being that nearer to the minimum capacity of T4.

Finally adjust T1 for maximum at the same time giving the main tuning a minute fractional adjustment. There is no padding operation.