

EKCO UAW70

Three valve, plus rectifier, three waveband vertical table type super-het for A.C. or D.C. operation. Made by E. K. Cole, Ltd., Green Park Hotel, Aston Clinton, Bucks.

Circuit.—The aerial input on all bands is through C1. On short-waves an aperiodic winding, L7, is coupled to L4, a simple grid coil. On medium and long bands, band-pass circuits lead to V1, the frequency-changer, the aerial being coupled through C2 on M.W. and L1 on L.W. L2 and L3 are the aerial circuit input coils for M. and L.W. respectively, L5 and L6 being the corresponding grid circuit coils.

The screen of V1 is fed by R1 and decoupled by C6. R2, the bias resistor, is decoupled by C7. R3 and C8 are the oscillator grid leak and condenser, feeding tuned grid coils. These coils are: S.W., L8; M.W., L9; L.W., L10.

Corresponding reaction coils, L11, 12, 13, are fed from the oscillator anode through R6 and C9. R4 is the anode feed resistor.

Conventional trimmer tuned I.F. transformers, L14-17, link up V2, the I.F. amplifier, and V3, the double diode output pentode. R8, decoupled by C14, provides standing bias for V2 in the usual way.

The A.V.C. diode of V3 is fed from V2 anode through C16. The voltage is developed across R17, R18, the bias for V2 being taken from the junction of these and decoupled by C13. Maximum A.V.C. is taken via R19, decoupled by C5, to the bottom of the V1 grid coils.

The demodulation diode load is R10. Between it and I.F.T.2 secondary are R9 and C15, 18, forming an I.F. filter. C19 feeds the volume control R11.

V3 is biased by R13 and R14, C22 being the electrolytic across these. The volume control is returned to the

CIRCUIT DIAGRAM

E. K. COLE, Ltd., do not permit us to publish the circuit diagram of this receiver. The review below, however, has been specially prepared so that few difficulties should arise on this account.

The circuit description gives the purpose of practically every component, and the values of these are given in the tables.

junction of R13, R14, through R12 (C20 in shunt). A third, negative feedback winding on the output transformer goes via R16 to the bottom of the volume control, the other line going to the R13, R14 junction.

V3 has a shunt tone condenser in C23 and a variable control in C24 and the variable R20.

H.T. smoothing is by a choke, L18, with electrolytics C26, C27, and an H.F. by-pass C25.

V4, the half-wave rectifier, is connected to one side of the mains through a filter choke, L19, with C28 in shunt. A similar choke connects the other mains

line to chassis via the pilot lamp which has R21 in parallel.

A tapped resistance R22 feeds the heaters in V4, 2, 3, 1 order.

Warning.—The chassis is live. Care must be taken to avoid shocks when servicing the set. No earth connection should be made except from the earth socket which is isolated from chassis by C3.

Wave Ranges.—15-50, 190-560, 900-2,000 metres. **Mains consumption:** 70 watts on A.C., 65 watts on D.C. **Dial lamp,** 6.2 volts, .3 amp. **Fuse:** 500 ma. type.

GANGING

I.F. Circuits.—Switch to L.W., gang at maximum, volume and tone at maximum. Inject 126.5 kc. to V1 grid and adjust I.F. trimmers for maximum.

These trimmers are located at the bottoms of the I.F. cans and are accessible from underneath.

Calibration.—See that the pointer coincides with the dial lines when gang is fully meshed.

S.W. Band.—Inject 20 mc., tune to this point and adjust T1 (on oscillator gang). Adjust T2 (aerial gang trimmer) at 15 mc.

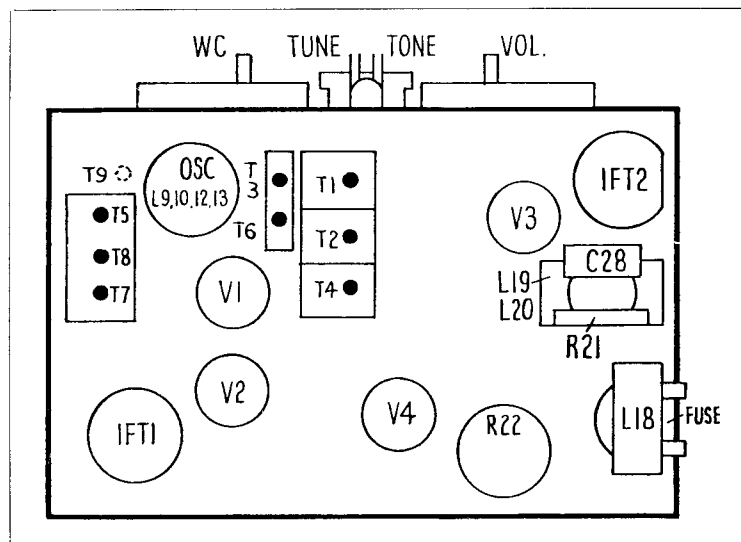

The Ekco chassis is very accessible. Except for the image rejector, all the trimmers are situated on the top of the chassis and are easily adjusted.

M.W. Band.—Tune to 200 m. Inject 1,500 kc. and adjust T3 (alongside gang).

Tune to 250 m., inject 1,200 kc., and adjust T4 (aerial gang trimmer) and T5 for maximum.

The padding condenser, C10, is fixed.

L.W. Band.—Tune to 1,300, inject 230 kc. and adjust T6 for maximum output with correct calibration. Then adjust band-pass trimmers, T7, T8.

Image Rejection.—Tune receiver to 747 kc., inject strong 1,000 kc., and adjust T9 for minimum.

VALVE READINGS

V	Type.	Electrode.	Volts.	Ma.
1	TH30C (Mullard)	Anode	178	3.8
		Screen	90	9.3
		Osc. Anode	80	4.6
2	VP13C (Mullard)	Cathode	1.7	17.7
		Anode	178	10.3
		Screen	178	3.7
3	Pen DD4021 (Mazda)	Cathode	1.5	14
		Anode	162	56
		Screen	168	11
4	40SUA (Cossor)	Cathode	18	67
		Cathode	215	100

RESISTANCES

R	Ohms.	R	Ohms.
1	10,000	11 (V.C)	850,000
2	100	12	15,000
3	100,000	13	120
4	20,000	14	160
5	470,000	15	1,000
6	150	16	47,000
7	1,000	17	470,000
8	120	18	470,000
9	100,000	19	1 meg.
10	560,000	20 (T.C)	20,000
		21	39

CONDENSERS

C	Mfd.	C	Mfd.
1	.002	15	.0002
2	.0005	16	15 cm.
3	.1	17	.8
4	.002	18	.0002
5	.1	19	.01
6	.1	20	.1
7	.1	21	.0002
8	40 mmfds.	22	.50
9	.001	23	.0025
10	2,000 pmfds.	24	.04
11	.25	25	.1
12	800 "	26	.1
13	.01	27	.8
14	.1	28	.1

WINDINGS

L	Ohms.	L	Ohms.
1	23	10	17
2	2.5	11	below 1
3	27	12+13	5
4	below 1	14, 15, 16, 17	70
5	2.5	18	390
6	27	19, 20	2
7	below 1	21	250
8	below 1	22	30
9	4.5	23	below 1

Those Mystery Faults

EVERY engineer knows what it is to come across faults which still remain after "everything has been tested." After trying everything he knows for an hour or two, the engineer reaches a point at which he attributes the trouble to the supernatural. Not in so many words; but that is what he means when he says, "I've proved everything is right" when the set is still, all too obviously, wrong.

At such times it is as well to go to some other job for a while, and then, when returning, remind oneself that every fault has a definite physical cause, and that this cause, even if its effects cannot be measured (which is unlikely), can still be tracked down to some limited section of the set.

For silence or weak signals and the elusive intermittent failure the stage-by-stage injection test, carried out with an oscillator, working back from the output valve, cannot fail to reveal the fault.

Most of these "sticky" troubles, however, are howling or noise in some form or other. With these the engineer must concentrate on localising the trouble—first to L.F. or radio sections (a set can always be operated as an L.F. amplifier only) and then to a particular stage.

In the case of instability, unless the set has been altered structurally (wires moved or screens de-earthed), the cause must be failure of decoupling components. The electrolytic on the output valve side of the smoothing choke is not always appreciated as a decoupling as well as a smoothing condenser.

Electrolytics, however, do not filter H.F. currents very well, and it is a good plan to provide a better path in the form of a .1 mfd. paper type condenser.

Hum and noise can generally be pinned down to one stage by shorting grid circuits.

Service Data Accuracy

WHEN checking receiver measurements, of both valves and components, exact correspondence with the figures in service manuals is not to be expected. Most manufacturers state that readings can be accepted as indicating correct operation as long as they are within plus or minus 10 per cent. of the figures published. A general similarity should be found, any large variation in one stage being viewed with suspicion.