

EKCO A21

Five valve, including rectifier and tuning indicator, superhet receiver for operation from AC mains 200-250 volts, 50-100 cycles. Five press-buttons are provided for the pre-selection of three MW and two LW stations. Manual tuning gives coverage on the LW, MW and SW wavebands. Provision for PU and external speaker. Wander-plug switch for disconnecting internal speaker. Marketed by E. K. Cole, Ltd., Southend-on-Sea. First production, February, 1946.

PERMEABILITY-TUNED RF transformers are used on each wave-range to feed the signal from the aerial to the grid of V1, the frequency-changer. L1 and L2 are the SW aerial and grid coils respectively, T2 being the variable trimmer. MW has a C2 across the aerial coil L3, L4 being the grid coil. LW uses C3 across the aerial coil L5

with both fixed and variable trimmers C5 and T3 across the grid coil L6.

The usual IF rejector circuit C1, T1 is connected between aerial and earth terminals. S1 and S2 provide the LW, MW and SW switching in the grid circuit while S3 brings the three MW pre-set push-button trimmers T7, T8 and T9 across L4. S4 brings the two LW push button pre-set trimmers T10 and T11 across L6 according to which button is depressed. VC1 is the main tuning capacitor, T12 being a pre-set trimmer.

Full AVC is both series and parallel fed, R1 is the parallel feed resistance and R25 provides decoupling. Cathode bias for V1 is derived from R3 and C6. Screen supply is from the same point as the oscillator anode, namely R6 decoupled by C16.

Permeability tuned transformers are again employed in the V1 triode oscillator circuit in a similar manner as in the RF circuit. L7 and L8 are the grid and anode coils on SW. C10 being a fixed padder in the grid circuit. MW employs L10 in the anode circuit and L9 in the grid circuit, a fixed padder C11 and trimmer T22 are incorporated. LW use L12 in the anode and L11 in the grid, C12 and T23 are fixed and variable trimmers. C13 is a fixed padder.

A separate transformer is used for the push-button oscillator circuits with a fixed capacity C14 across the grid coil L13, the anode coil being L14. The pre-set push-button circuits are completed by variable iron dust cored coils T13, T14, T15, T16

and T17, the first three being the MW ranges and the last two the LW ranges.

Automatic grid bias is obtained from C9 and R4. R5 is an anti parasitic-oscillation device. Main oscillator tuning capacitor is VC2 with its trimmer T24. Decoupling by R2, C15, is provided for the hexode anode circuit.

First IF transformer uses variable iron-dust cored coils which are mounted at right angles to minimise mutual induction. Coupling is "top inductive"

Continued overleaf.

VALVE READINGS

V Type	Electrode	Volts	Ma
1 ECH35	Anode	250	3.6
	Screen	100	2.9
	Osc. Anode	100	3.3
	Cathode	2.1	—
2 EF39	Anode	255	7.5
	Screen	104	2.3
	Cathode	2.1	—
3 EBL31	Anode	240	34.7
	Screen	255	3.3
	Cathode	12.5	—
4 AZ31	Anode (AC)	295	—
	Cathode	—	—
5 EM34	(Smoothed HT)	255	58
	Anode	255	—

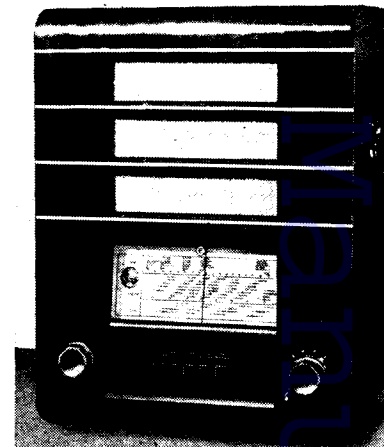

RESISTORS

R	Ohms	R	Ohms
1	2.2 meg	14	680,000
2	1,500	15	15 V/C
3	220	16	12,000
4	47,000	17	47,000
5	220	18	150
6	27,000	19	180
7	68,000	20	560,000
8	220	21	470,000
9	47,000	22	47
10	1 meg	23	20,000
11	1 meg	24	1 meg
12	6.8 meg	25	100,000
13	1.5 meg		

CAPACITORS

C	Mfd	C	Mfd
1	39 pf	18	.1
2	330 pf	19	.05
3	820 pf	20	150 pf
4	.1 mfd	21	150 pf
5	82 pf	22	15 pf
6	.1	23	120 pf
7	150 pf	24	100 pf
8	150 pf	25	.1
9	68 pf	26	.02
10	3900 pf	27	39 pf
11	560 pf	28	Electrolytic 50
12	200 pf	29	.0025
13	330 pf	30	.04
14	270 pf	31	Electrolytic 16
15	.1	32	8
16	.1	33	.02
17	.1	34	.1

INDUCTORS

L	Ohms	L	Ohms
1	very low	17	5
2	very low	18	5
3	9.5	19	350
4	2	20	.5
5	33	21	42
6	23	22	700
7	very low	23	very low
8	very low	24	390 plus 370
9	2.5	25	very low
10	very low	26	45 max
11	3.5	T 1	15
12	very low	T13	2
13	8.5	T14	3.6
14	5	T15	4.5
15	5	T16	5.7
16	5	T17	6.4

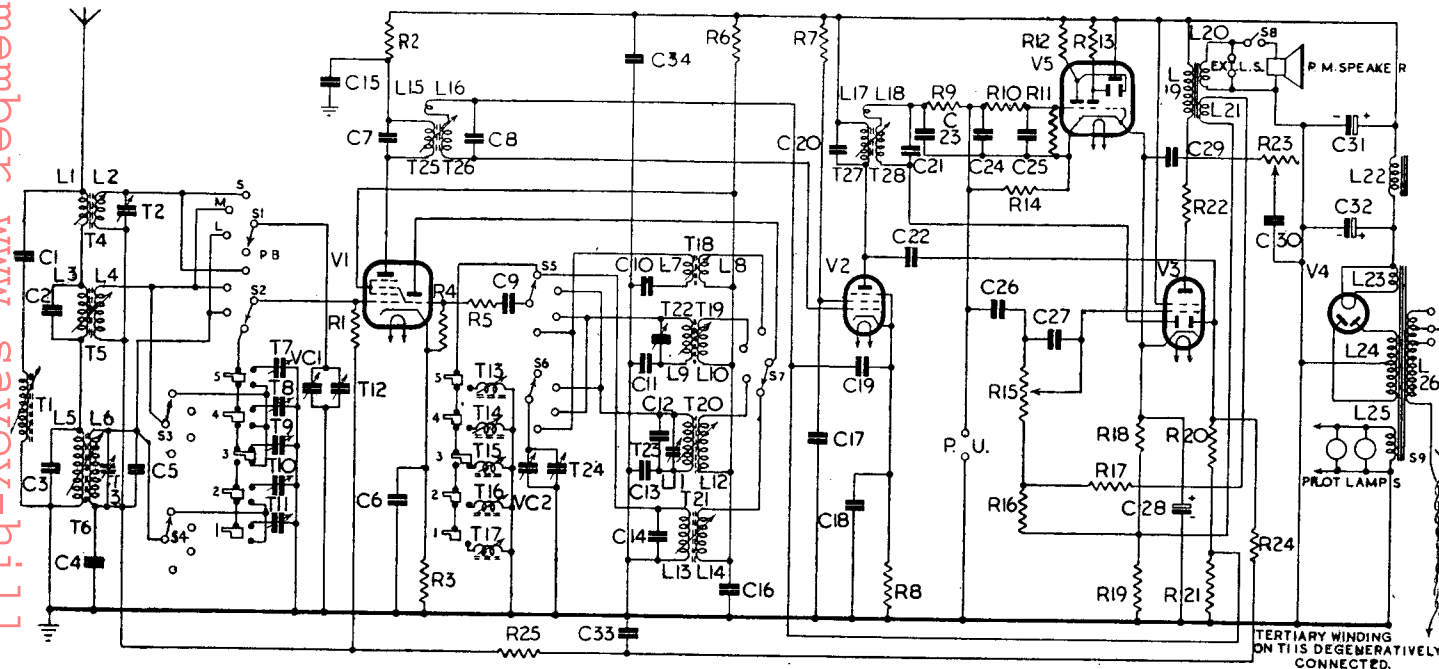

The model A21 is a "short" superhet with the double diode combined with a high-slope output pentode. V4 is a full-wave rectifier, and V5 a cathode-ray type tuning indicator. Three wavebands are covered by manual tuning and there are also five push-buttons for automatic tuning.

EKCO A21—Continued

by a special winding. Primary is made up of L15 and C7 while the secondary is L16, C8. About half the AVC is series fed to the IF valve, V2, via the secondary, decoupling is by C19.

V2 uses cathode bias from R8, C18. Screen dropping resistance is R7 decoupled by C17.

Second IFT is similar to the first and passes the signal to the signal diode only of V3. Its primary is composed of L17, C20 and the secondary L18, C21.

An IF filter, formed by C23, R9, C24, is incorporated in the detector diode circuit whose load is R14.

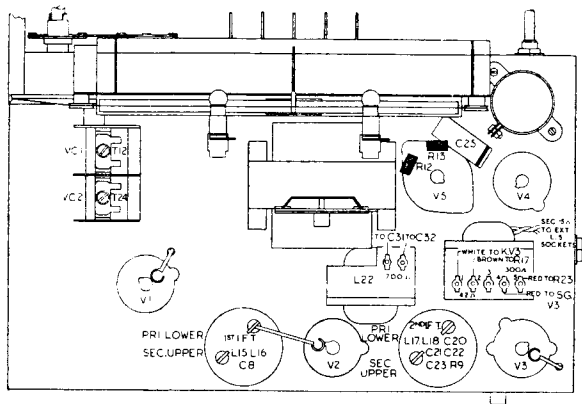

Above: How components are arranged on the A21 chassis, and, left, under-chassis diagram identifying the small components. Note that to speed reference resistors are drawn in black.

of the 3-ohm impedance type by a plug and socket arrangement at rear of chassis; the set speaker is of the permanent-magnet type.

Mains transformer primary has tappings for 200-210, 220-230, 240-250 volts, 50-100 cycle AC mains. A 6.3v heater and pilot lamp winding L25 and a 4v rectifier heater winding L23 are provided. Full-wave HT circuit uses L24 for the anode supplies; smoothing is accomplished by a condenser input filter C32, L22, C31. C34 is an RF by-pass.

REPLACING CORD DRIVE

The cord which is 46 inches long should be tied by a clove hitch knot to the top of the cursor leaving an equal length each side. Fully mesh the gang and adjust the drive wheel so that the small hole in its rim occupies a position corresponding to 4 o'clock. Hold the cursor so that the pointer is flush with the line terminating the 50-metre end of the SW scale.

One half of the cord should be passed over the right hand pulley, clockwise along the drive wheel down to the drive spindle. Give the cord one and one-half turns round the spindle then up and clockwise round the driving wheel through the small hole in the rim and then tie to a small soldering tag about half an inch inside the rim.

The other half of the cord should be taken over the left hand pulley then down under the drive wheel and anti-clockwise round the rim into the same small hole. Terminate on a small tag as before.

One end of the tension spring is now hooked into

Continued on page viii

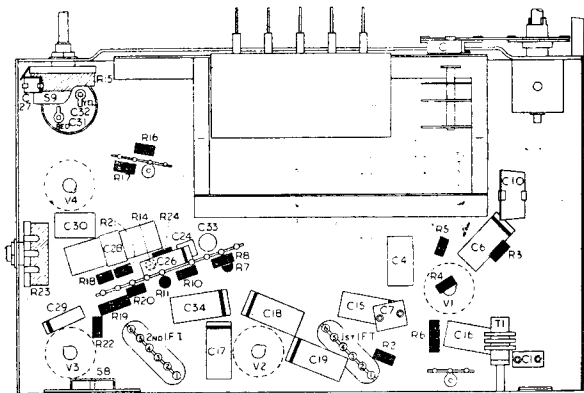

The tuning indicator is driven from this point via filter network R10, C25, R11. The majority of models use an EM34 in which case R12 and R13 are the anode resistances. A few early models use an EM1 in which case R12 is deleted and R10 is replaced by 6.8 megohms.

AVC diode is connected to the IF valve V2 anode by C22, its anode load being R20 and R21. About half AVC is therefore tapped and applied to V2 while full AVC is supplied to the frequency-changer, R24, C33 forming a low-pass filter.

Delay is obtained from the volts drop across R18 and R19 in the cathode lead, decoupled by C28.

Audio voltages are fed to the volume control by C26, as also is the pickup input. C27 is an IF by-pass across the volume control when it is turned down.

Negative feed-back voltages from a separate winding L21 on the output transformer are developed across R16 which is in series with the volume control. R17 provides isolation.

Cathode bias is from R18 alone. An anode stopper R22 is used in the output circuit with fixed tone control by C29, variable tone control is effected by R23 and C30.

Full HT is used upon the screen of the output valve. Provision is made for an external speaker

SOLON ELECTRIC SOLDERING IRON

SOLON ELECTRIC INSULATION STRIPPER

SOLON ELECTRIC SOLDER POT

SOLON Industrial Electric Appliances are designed for practical use under factory conditions. They are robust and efficient. The Soldering Iron illustrated is representative of a range which includes models with various types of bits suitable for a wide variety of jobs. Models are available for low voltage supply as well as for standard voltages. The Insulation Stripper provides a quick method of severing the insulation neatly without damaging the conductor, by means of an electrically heated wire. The Solder Pot maintains 1-lb. solder at working temperature.

Please write for Folder Y9

W. T. HENLEY'S TELEGRAPH WORKS CO. LTD.
51-53, HATTON GARDEN, LONDON, E.C.1

STURDY FOR REWINDS

For all-round satisfaction, send your rewinds to Sturdy. First-class work, returned in the shortest possible time, and fully guaranteed. For the trade only.

STURDY ELECTRIC CO., LTD.
DIPTON, NEWCASTLE-ON-TYNE
Phone: DIPTON 221. Lists on Application.

"What's going on here!" hollered EE, as he came sailing down with the tree, 'Got that aerial right, 'fixed her up with FLUXITE, 'then you chop it down! It beats me."

For all SOLDERING work you need FLUXITE—the paste flux—with which even dirty metals are soldered and "tinned." For the jointing of lead—without solder and the "running" of white metal bearings—without "finning" the bearing. It is suitable for ALL METALS—excepting Aluminium—and can be used with safety on Electrical and other sensitive apparatus. With FLUXITE, joints can be "wiped" successfully that are impossible by any other method. Used for over 30 years in Government works and by leading Engineers and Manufacturers.

OF ALL IRONMONGERS, in tins—8d., 1/4 & 2/8
"The FLUXITE GUN" puts Fluxite where you want it by a simple pressure. Price 1/6 or filled 2/6.

FLUXITE

SIMPLIFIES ALL SOLDERING

Write for Leaflets on Case-Hardening Steel and Tempering Tools with FLUXITE, also on "Wiped" joints. Price 1d. each.
FLUXITE LTD. (Dept. T.E.), Bermondsey St., London, S.E.1

EKCO A21—Continued

both small tags while the other end is fitted over the hook in the drive wheel.

With the gang fully open the pointer should coincide with the datum line. Any slight error not exceeding a half an inch either way can be corrected by loosening the drive wheel on the gang shaft and moving until the pointer is correct. Tighten grub screws on the drive wheel.

ALIGNMENT INSTRUCTIONS

Apply Signal as Below.	Tune Receiver to (metres)	Adjust in Order stated for Max. Output.
(1) 477 KC between V1 grid and chassis via .02 mfd condenser, leaving existing lead connected	MW 560	T23, T27, T26, T25
(2) 477 KC between aerial and earth	MW 560	T1 for min.
(3) 15 MC between aerial and earth via dummy aerial	SW 20	T24
(4) As in (3)	SW 21.4	This is the "image" signal and is useful for checking calibration with (3)
(5) 1,200 KC between aerial and earth via dummy aerial	MW 250	T22, T19
(6) 1,304 KC as in (5)	MW 230	T12
(7) 15 MC as in (3)	SW 20	T2
(8) 230.8 KC via an LW dummy aerial	LW 1,300	T23, T3
(9) 176.5 KC as in (8)	LW 1,700	T20, T6

Use of an output meter in parallel with speech coil is strongly recommended. An AC 0-100v meter of the universal type, not less than 20,000 ohms resistance, is suitable.

Pointer should coincide with 560 metres when the gang is fully meshed.

Turn volume and tone controls fully clockwise before trimming.

PUSH-BUTTON ADJUSTMENT

Remove escutcheon and detach trimming tool which is clipped to the back. Each button has its associated trimmer and coil immediately above and below it. Coverages are: button (1), 1430-1986 metres; (2) 1160-1640 metres; (3) 342-560 metres; (4) 267-450 metres; (5) 200-308 metres. Buttons are numbered left to right when facing front of receiver.

Fully unscrew the lower screw of button to be set. Turn volume to max. and wavechange to push-buttons (white). Press required button. Slowly rotate lower screw clockwise until desired station is received. Adjust upper screw to max. Adjust both for max. shadow on tuning indicator.

GEC 4650—Continued

Screen voltage for V2 is fed from R11 and R17 decoupled at the electrode by C13.

IFT2 primary consists of iron-dust coil L11 and trimmer T11. Secondary, L12, and trimmer T12, feed the signal to the detector and, via C15, to the AVC diode.

Signal diode load is R14; R13 and C16 provide IF filtering. C17 passes the AF voltages to the volume control R16 and hence to the triode grid. PU terminals are connected across R16.

AVC diode load is R15, a delay being obtained from R26. Cathode bias for V3 is provided by R19 decoupled by C20. Amplified AF voltages appear across the triode anode load R18. C19 provides fixed tone control and further IF filtering. Coupling to the output valve V4 is by C21 and C22 in parallel with R21. The latter two components are short circuited on SW by S7 to increase the overall sensitivity.

R20 is the usual grid resistor, R23 and C23 being fixed tone control. R24 provides cathode bias and negative current feedback is obtained by omitting the by-pass condenser. Screen supply is via a series resistance R22 which is not decoupled.

Output transformer primary L13 has C24 in parallel for treble cut and to even out the response. Provision is made for external speaker of the low impedance type by connections at the rear. The set speaker is of the permanent magnet type. Variable tone control is effected by C25 and R25.

Models BC4650 and BC4650L are identical with the exception of the mains transformer voltage range. The 320-0-320V winding L17 has its centre tap returned to earth via R26 to provide standing bias for V1 and V2. The 6.5V heater and dial light winding L19 is earthed on one side. A 5V rectifier heater winding L18 is used. Smoothing is accomplished by condenser input filter C27, choke L16 and C26.

DRIVE WIRE REPLACEMENT

Before the wire drive can be replaced it is necessary to remove the pointer, speaker and baffle. Place chassis with controls facing the operator, fully disengage gang condenser, move pointer drive wheel so that fixing screw at rear is at 9 o'clock as in diagram (see page iv).

Fasten one end of the wire under front securing screw (now at 8 o'clock) on tuning drive wheel, pass around groove in an anti-clockwise direction for a half-turn and then direct to and over the pointer drive wheel.

After making slightly more than a complete turn anti-clockwise, the wire is looped around the locating screw on the back of the pointer wheel and secured. Continuing in the groove in the same direction the wire is passed under the tuning drive wheel and along the groove in an anti-clockwise direction terminating under the head of the screw fixed at 10 o'clock on the rear of the wheel.

VIDOR CN222—Continued

the field winding which also acts as a smoothing choke.

On AC supplies high tension is derived from the mains via the half-wave rectifier V4 whose heater is in series with the other valve heaters in the usual way across the mains input.

Chokes L14 and L15 are provided for HF filtering.

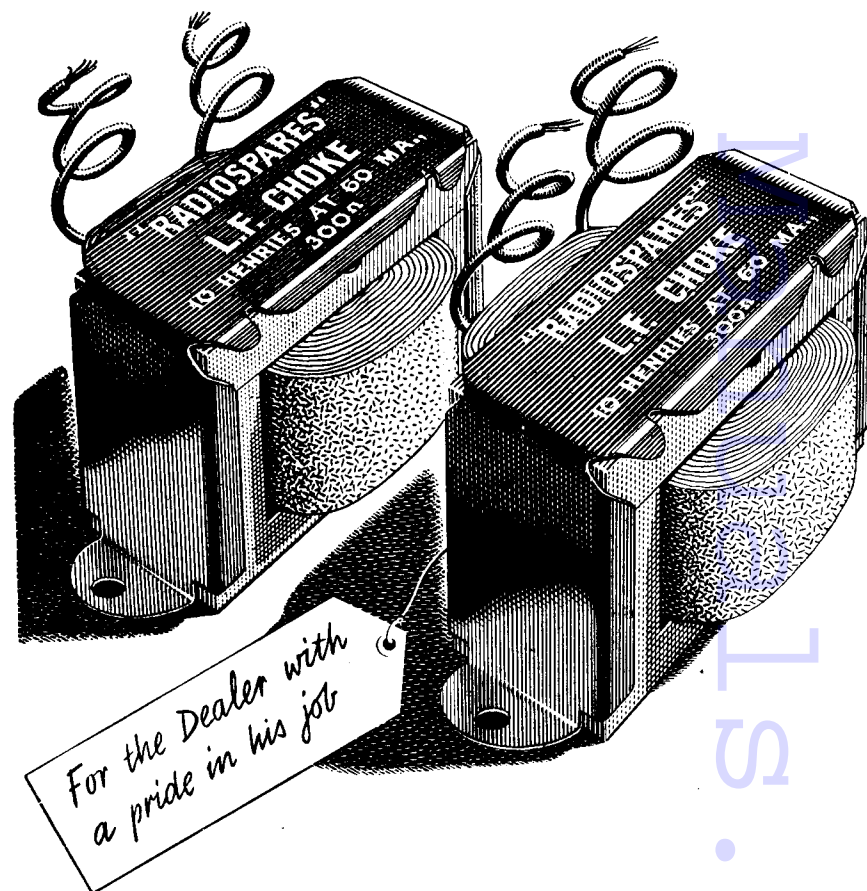

We present our range of L.F. (Smoothing) Chokes. They are guaranteed quality components with the following general characteristics. WINDINGS: paper-interleaved, wax-impregnated. LAMINATIONS: high-mu alloy steel. OVERALL HEIGHT: 2 in. OVERALL WIDTH: 2 $\frac{3}{4}$ in. (fixing centres: 3 $\frac{1}{8}$ in.). OVERALL DEPTH: 1 $\frac{7}{8}$ in. (Stack only: 1 $\frac{1}{8}$ in.). They are available in two distinct types. (1) INDUCTANCE: 10 Henries, capacity: 60 M/a. RESISTANCE: 300 Ω . (2) INDUCTANCE: 40 Henries, capacity: 30 M/a. RESISTANCE: 1250 Ω . The price of both types is 6/9 each net trade; and they are obtained only direct from

Radiospares Ltd.

44 BIRCHINGTON ROAD, LONDON, N.W.6. TEL: MAIDA VALE 9386-7