

BURNDEPT MODEL 270 ALL-WAVE



The Burndeft 270 is a four wave-band, straight three battery instrument selling at £8 5s.

CIRCUIT.—For medium and long waves the aerial is coupled to the first valve by a band-pass filter. On the two short waves it is inductively coupled. The first valve, V1, is an H.F. pentode which is coupled direct to V2, a triode, by a tuned anode coil. Reaction is fed back from the anode in the usual manner.

Signals are fed to V3, an output pentode, through an L.F. transformer. The amplified output of this valve is fed to the permanent magnet moving-coil speaker through a special matching transformer.

The volume control varies the bias on the grid of the H.F. pentode. Bias for this valve is obtained from the battery. For the output valve, however, it is obtained by the voltage drop across R7, the series bias resistance.

The on-off switch is ganged to the volume control. In the "off" position it isolates both H.T. and L.T. from the set.

H.T. is obtained from a Vidor H.T. battery, number 18580, and L.T. from a Vidor "Triplate" 25 amp. hour accumulator.

Removing Chassis.—The cabinet is provided with a false bottom, and for all ordinary repairs it should not be necessary to remove the chassis.

If this is found necessary, however, remove the four knobs from the front of the cabinet, which are held by grub screws. Next remove two wood screws holding the battery leads to the battery shelf.

Finally, take out the four screws holding the chassis to the bottom of the

cabinet and, if necessary, disconnect the two leads to the speaker, remembering on reconnection that the black lead connects to the top tag on the speaker transformer.

Special Notes.—The dial lights clip on to the brackets on the dial assembly, so it is an easy matter to remove them for renewals, should this be necessary.

The bulbs are of the screw-in type and are rated at 2.6 volts .3 amp.

Circuit Alignment Notes

After noting that the pointer travels fully to each end of the scale, proceed as follows :—

Medium Waves.—Inject a 250-metre (1,200 kc.) signal into terminal A2 with input control screwed up moderately tight.

Switch to medium waves (range 3). Turn the pointer to 250 metres on the scale, and with the volume control turned full on and with reaction advanced, adjust main anode trimmer until signal is tuned in at maximum strength. Then adjust the main-grid trimmer likewise.

RESISTANCES

R.	Purpose.	Ohms.
1	V1 bias potentiometer (part) ..	500
2	Reaction modifier ..	300
3	V2 grid leak ..	1 meg.
4	V2 grid leak pot. (part) ..	200
5	V2 grid leak pot. (part) ..	200
6	Secondary shunt ..	150,000
7	Series bias ..	150

CONDENSERS

C.	Purpose.	Mfd.
1	Bias decoupling ..	.1
2	V2 grid condenser ..	.0001
3	H.T. shunt ..	.25
4	H.F. filter ..	.00005
5	H.F. filter ..	.0002
6	V3 screen decoupling ..	8
7	Pentode compensator ..	.005
8	V3 series bias shunt ..	50
9	Top band-pass coupling ..	.00009

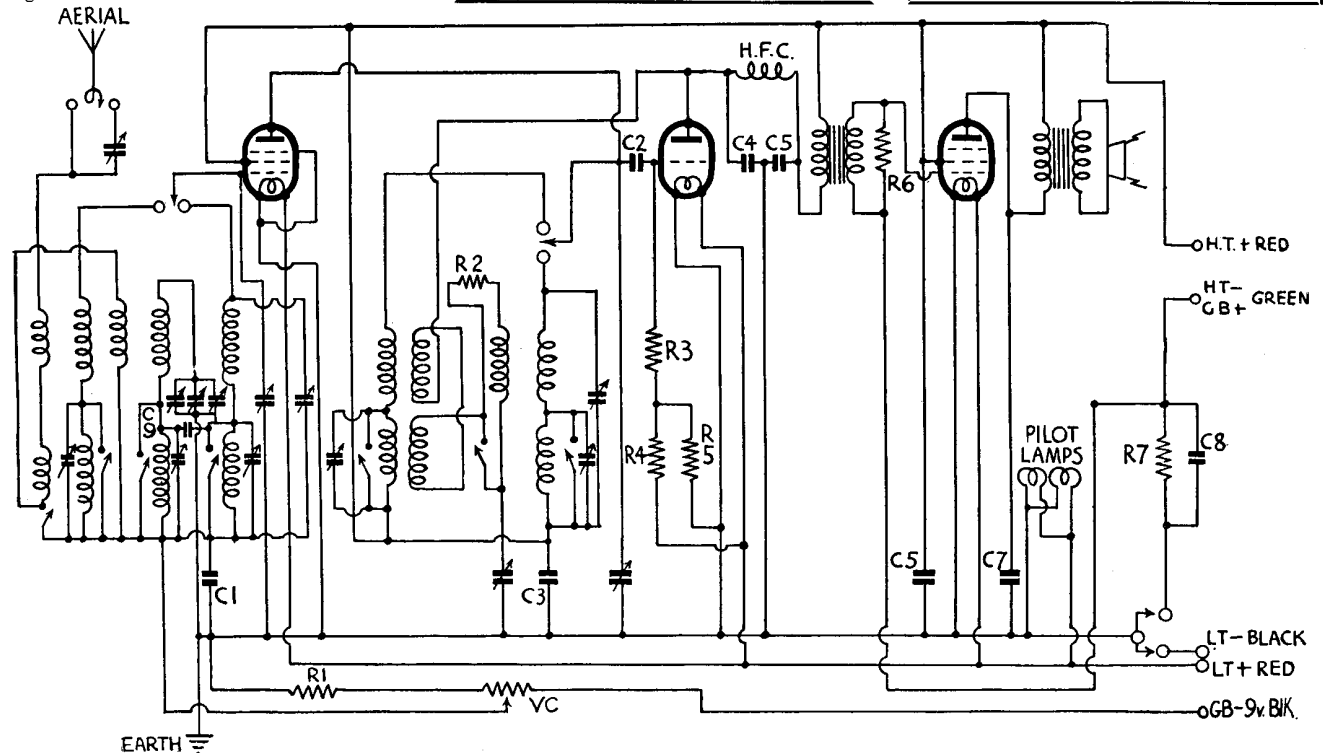

Theoretical circuit arrangement of the Burndeft Model 270. The valve sequence is Mullard V.P.2., H.F. pentode ; Mazda H.L.2., triode detector ; and Mullard Pen 22D, output pentode.

Both of these trimmers are placed under the chassis in front of the receiver, and access to them is obtainable through holes in the chassis top near scale ends.

Next adjust the aerial trimmer on the gang condenser. This in all probability will be found to be screwed up tightly. If this is so, adjust the additional aerial trimmer under the chassis.

During this process reaction should be kept advanced as far as possible without oscillation actually taking place.

Checking calibration by injecting various signals from 250-500 metres (1,200-600 kcs.) metres should then be done.

Long Waves.—Next switch the set to long waves (range 4) and inject 1,000 metres (300 kc.). Turn the pointer to 1,000 metres calibration on scale and adjust long-wave anode trimmer, then long-wave grid trimmer, and finally long-wave aerial trimmer keeping reaction advanced as before.

Check the calibration at various points on long waveband.

Short Waves.—Switch the set to short waves (range 2) and inject 75 metres. Set the pointer to the 75 metre (4 megacycle) calibration and adjust main short-wave anode and main short-wave grid trimmers, again with the reaction well advanced.

Calibration over the rest of the waveband should then be checked.

Ultra Short Waves.—The ultra short

VALVE READINGS

Volume maximum. No reaction. No signal.
New batteries.

V.	Type.	Electrode.	Volts.	Ma.
1	Mullard VP2 met. (7)	Anode .. Screen ..	106 100	2.0 .5
2	Mazda HL2 met. (5)	Anode ..	100	2.9
3	Mullard Pen 22D (5)	Anode .. Screen ..	105 110	4.9 .7

Burndept 270 on Test

MODEL 270.—Standard model for battery operation, fitted with Vidor 18580 H.T. battery and Vidor "Triplate" 25-a.h. L.T. cell. Price £8 5s.

DESCRIPTION.—A four waveband, straight three battery receiver with separate volume and reaction controls and pentode output.

LOADING.—L.T., 1.13 amp.; H.T., 10 ma.

Sensitivity and Selectivity

SHORT WAVES (13.8-49 metres; 75-210 metres).—Performance is particularly good, the set handling easily. The gain is quite good and the reaction is very smooth, which makes critical tuning a simple matter.

MEDIUM WAVES (200-550 metres).—Gain and selectivity are representative for the valve combination employed, the aerial coupling being fairly heavy. Careful use of volume and reaction controls is necessary to obtain a number of stations between the local transmissions.

LONG WAVES (900-2,200 metres).—Somewhat similar performance to the medium waveband, with sufficient gain to give good programme strength from the main stations without difficulty in separation.

Acoustic Output

Quite good for a small battery pentode, with a reasonable consumption. The balance is nicely arranged and colouration is by no means unduly marked.

wave range (1) has no separate trimmers, and calibration should be correct, but slight adjustments may be made by slightly altering the position of the leads to the grid and anode relative to the rest of the wiring under the chassis.

REPLACEMENTS

Exact replacement condensers are made for two units in the Burndept 270 by A. H. Hunt, Ltd., of Garratt Lane, Wandsworth, London, S.W.18.

For C6, the 8 mfd. output valve screen decoupling condenser, is Type 1,956, at 1s. 9d.; for C8, the 50 mfd. output valve bias shunt, is Type 2,915, also at 1s. 9d.

Suitable batteries for this receiver are marketed by Exide Batteries, of Clifton Junction, near Manchester.

For H.T. is the Drydex battery Type X496; for L.T. is the Exide 2 v. Hycap accumulator Type OCG3-C.

"Within Plus or Minus—"

Of six new A.C.-D.C. sets, two were found to have bad L.F. instability on the local mains (200 v. A.C.).

One of the faulty sets was tested through, and a smoothing condenser rated at 6 mfd. came under suspicion. Testing with a bridge a reading of 5.35 mfd. was obtained. There was no fault in the condenser; but it caused the trouble.

The margin of error on the low-reading units had been on the wrong side for the exceptional conditions in my area.—W. G. G.

This is the lay-out of components on the top of the chassis of the Burndept 270. The volume control is ganged to the on-off switch and controls the bias on the H.F. pentode, which is derived from a battery. The output valve is biased by the voltage drop across R7.

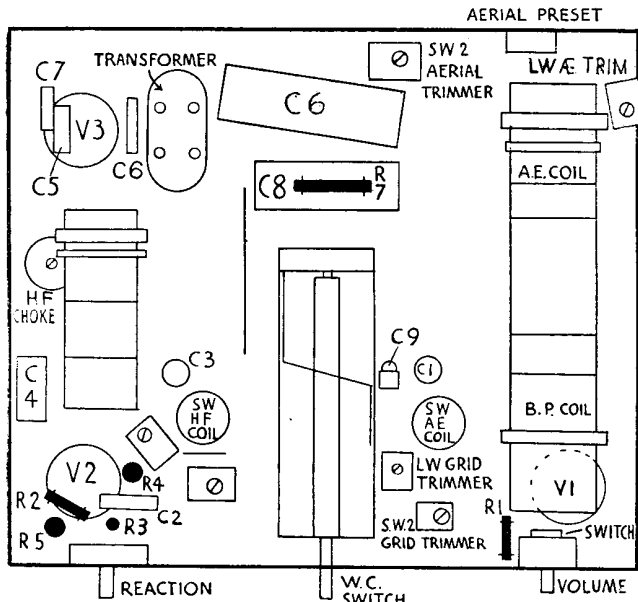
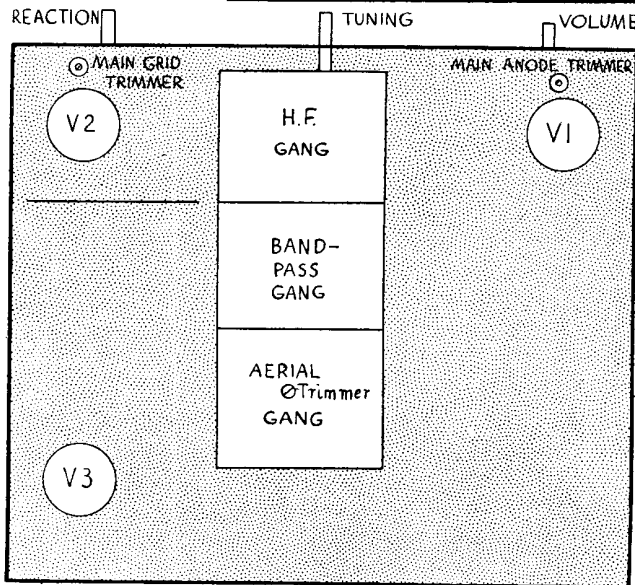

The underside of the chassis, illustrated here, is accessible without removing the chassis from the cabinet, as the latter has a false bottom that may be removed for servicing purposes. Note that there are no trimmers for the ultra-short wave-range.