

BELMONT MODEL 700 ALL-WAVE



Belmont describe their Model 700 as a seven-valve instrument, the seventh valve being the cathode-ray type tuning indicator. The set is a 3-waveband superhet for A.C. operation.

CIRCUIT.—The aerial is inductively coupled to V1, a heptode, where the incoming signals are mixed with those generated by V2, a triode valve acting as a separate oscillator. The resulting frequency then passes through an I.F. transformer to V3, an H.F. pentode acting as the I.F. amplifier.

The output of V3 passes through another I.F. transformer to the demodulating diode of V4, a double diode triode. The second diode provides a D.C. potential that is fed back to give A.V.C. A variable resistance acts as the demodulator diode load, and the slider is connected to a fixed condenser forming the coupling to the grid of the triode section of V4. A tuning indicator is fed from the diode circuit of V4.

V4 is resistance capacity coupled to V5, an output pentode. A variable resistance and a fixed condenser connected in series across the anode circuit provide a control of the tone. A fixed condenser, which can be connected between the anode and chassis, supplements the variable tone control.

Mains equipment consists of a mains transformer with the usual voltage compensation windings, electrolytic smoothing condensers, full wave rectifying valve and smoothing choke (speaker energising field coil). The latter is in the negative H.T. line.

Special Notes.—The mains voltage adjustment is to be found at the rear of the chassis and is revealed by removing the metal plate which is secured by two wing nuts and bolts.

A pair of sockets at the rear of the chassis sub-panel enable a pick-up to be

connected. A switch located above these sockets is designed to cut off the radio input to the L.F. amplifying stages when the receiver is being used for records.

There are two dial lights, one each side of and supported by the wavelength dial assembly. These are mounted in screw-in holders and are partly enclosed by tubes fitting over the holders. They are rated at 6 to 8 volts .15 amp.

In our particular chassis R5 was found to have a value of 19,000 ohms. R17 is inside the enclosed holder of the 6GS visual tuning indicator.

Chassis Removal.—The back of the cabinet is secured by two sliding clips. The four control knobs on the front are of the spring fixed type, and are removed by a pull.

Remove the four fixing bolts and washers in the base of the cabinet. With

these out the chassis can be withdrawn to the extent of the speaker cable and tuning indicator leads.

The speaker cable is connected to a non-reversible five-pin holder and fits into a socket located at the front of the chassis. The tuning indicator can be removed by unscrewing the wing bolt observed on the valve support.

RESISTANCES

R.	Purpose.	Ohms.
1	V1 A.V.C. decoupling ...	100,000
2	Injection grid series resistance ...	150
3	Oscillator grid leak ...	50,000
4	Oscillator anode load ...	9,000
5	V1, V2 screen decoupling ...	10,000
6	Regeneration modifier ...	50
7	V2 A.V.C. decoupling ...	1 meg.
8	Volume control and demodulator diode load ...	1 meg.
9	V4 triode section grid leak ...	3 meg.
10	V4 anode load ...	100,000
11	V5 grid leak ...	500,000
12	Bias potentiometer (part) ...	220
13	Bias potentiometer (part) ...	33
14	Bias potentiometer (part) ...	52
15	Tone control ...	50,000
16	Pick up shunt ...	100,000
17	Tuning indicator anode feed...	1 meg.
18	Field coil ...	1,550

CONDENSERS

C.	Purpose.	Mfds.
1	V1 A.V.C. decoupling05
2	V1, V3 screen decoupling1
3	V2 oscillator grid00005
4	M.W. oscillator shunt00004
7	Oscillator fixed padder003
8	V4 bias decoupling1
9	V2 A.V.C. decoupling05
10	H.F. by-pass00025
11	L.F. coupling01
12	H.F. by-pass00025
13	L.F. coupling01
14	Tone control025
15	H.T. smoothing ...	8
16	H.T. smoothing ...	8
17	Pentode compensator002

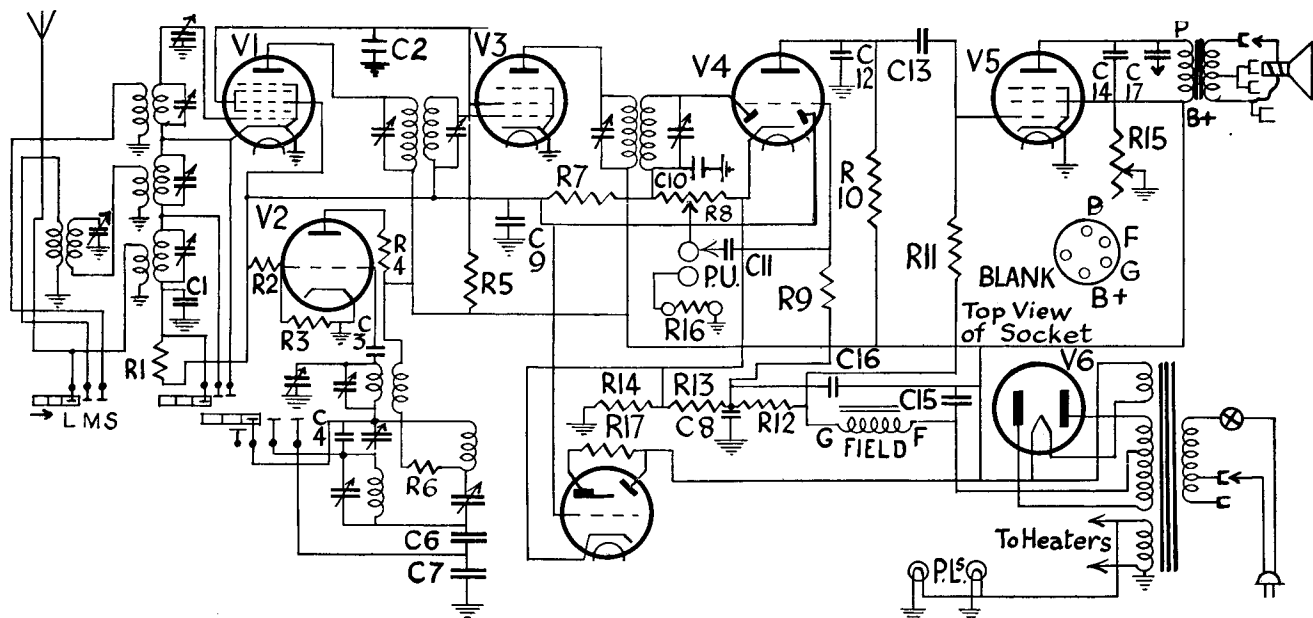

A separate oscillator valve, in addition to a heptode input valve, is one of the points to be noted in the circuit arrangement of the Belmont 700. The speaker field is in the negative H.T. line.

Circuit Alignment Notes

I.F. Circuits.—Connect a service oscillator between the top grip cap of V1 and chassis via a .01 mfd. condenser. Connect an output meter across the primary of the speaker transformer. Turn the volume control to maximum and tune the set to 1,400 kc. (214 metres).

Tune the service oscillator to 465 kc. and adjust the trimmers of the I.F. transformers until maximum response is obtained, reducing the input from the oscillator as the circuits come into line to render the A.V.C. inoperative.

Signal Circuits.—Leave the output meter connected as before. Only feed sufficient input from the service oscillator to obtain a half-scale deflection on the output meter

so as to render the A.V.C. inoperative.

Short Waves.—Connect the oscillator to the set via a dummy aerial consisting of a .1 mfd. condenser and a 400 ohms resistance connected in series.

Tune the oscillator to 18.2 mc. (16.5 metres) and turn the gang to minimum capacity. Adjust the S.W. oscillator trimmer for maximum.

Tune the set and oscillator to 17 mc. (17.7 metres) and adjust the S.W. aerial trimmer for maximum.

Medium Waves.—Connect the oscillator via a 200 mmfd. condenser and a 200 ohms resistance in series.

Tune the oscillator to 1,600 kc. (187.5 metres) and tune the gang to minimum. Adjust the M.W. oscillator trimmer for maximum.

Tune the set and oscillator to 1,400 kc. (214 metres) and adjust the M.W. aerial trimmer for maximum.

Tune the set and oscillator to 600 kc. (500 metres) and adjust the M.W. padder for maximum, simultaneously rocking the gang to ensure optimum results.

Long Waves.—Leave oscillator connected as before. Tune oscillator to 350 kc. (857 metres) and gang condenser to minimum. Adjust the L.W. oscillator for maximum response.

Tune the set and oscillator to 325 kc. (937 metres) and adjust the L.W. aerial trimmer for maximum.

Tune the set and oscillator to 150 kc. (2,000 metres) and adjust the L.W. padder for maximum, simultaneously

Belmont 700 on Test

MODEL 700.—Standard model for 220-260 volts, 50 cycles. Price 13 gns.

DESCRIPTION.—Five-valve, plus rectifier, plus tuning indicator, A.C. superhet covering three wavebands. Horizontal table type cabinet.

FEATURES.—Separate oscillator valve. Cathode-ray tuning indicator. Waveband indicator operated by switch. Name- and wavelength-calibrated full-vision scale, edge-illuminated. P.U. sockets. Cabinet size 21 in. wide, 10½ in. deep, 11½ in. high.

LOADING.—47 watts.

Sensitivity and Selectivity

SHORT WAVES (16.5-56.5 metres).—Good sensitivity and selectivity. No appreciable drift. Easy tuning.

MEDIUM WAVES (187-588 metres).—Average gain and selectivity. Local stations spread only to adjacent channels. Gain reasonably well maintained over waveband. Quiet background.

LONG WAVES (860-2,150 metres).—Performance similar to that on medium waves. All usual stations received well. Slight overlap on Deutschlandsender.

Acoustic Output.

Representative balance with very good high note response, crisp attack and forward tone. Speech reproduction very good. Tone control evenly graded.

VALVE READINGS				
No signal. Volume maximum. 200 volts A.C mains.				
V.	Type.	Electrode.	Volts.	Ma.
(All octal bases valves)				
1	6L7	Anode ...	190	3
		Screen ...	75	5
2	6C5	Anode ...	130	6.2
3	6K7	Anode ...	190	5.5
		Screen ...	75	1.5
4	6Q7	Anode ...	82	Inaccessible.
5	6F6	Anode ...	185	19
		Screen ...	190	3.1
6	5Y3	Filament	190	—

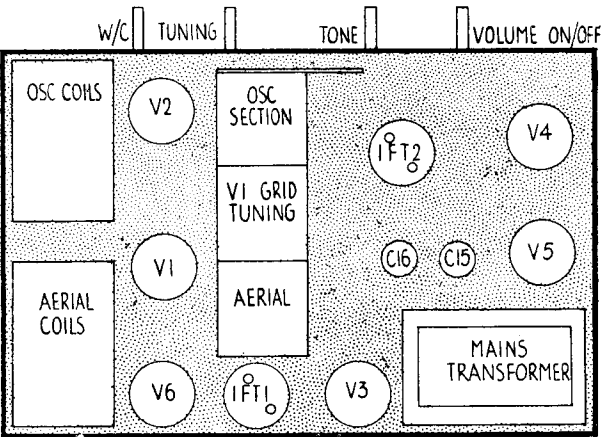

Left is the layout of the upperside of the chassis of the Belmont Model 700 all-wave superhet.

rocking the gang to ensure optimum reading on output meter.

As the medium and long-wave bands are to a certain extent interdependent, check the calibration of the medium wave band after lining up the long-wave band, and, if necessary, compensate for errors in calibration.

Replacement Condensers

Two replacement condensers for the Belmont 700 are available from A. H. Hunt, Ltd., of Garratt-lane, Wandsworth, London, S.W.18.

These are: Type list number 3551 for C15, price 4s. 6d.; type 3600 for C16, price 3s. 9d.

“Repair” that Wasn’t

Poor selectivity and volume on long waves on a superhet with a pre-H.F. stage did not yield to any adjustment, and it required very careful inspection to find that a previous “repairer” had broken one of the fine lead-out wires to the L.W. anode coil.

The ends had been twisted together and soldered, but the wire was enamelled and the joint a bad one.

“Servicing with Set Analyzers” is the name of a little book published by Radcraft Publications, Inc., of 99, Hudson-street, New York, and written by H. G. McEntee. It explains the theory and construction of set analyzers and follows this with a careful explanation of how they should be used. The second half of the book is devoted to descriptions and illustrations, including circuits, of analyzers on the American market.

Right, the underside view of the chassis clearly shows the arrangement of the various components employed. The majority are suspended in the wiring and are easily traced.

