

BELMONT 650 MIDGET

Four-valve, plus rectifier, midget three-waveband superhet for 200-250 volt A.C. or D.C. supplies. Marketed in 1938 by British Belmont Radio, Ltd. Present service agents: Price and Co. (Manchester), Ltd., 78, Tib Street, Manchester, 4, and Shannons and Bishop, Ltd., 182, Wardour Street, London, W.1.

Circuit.—The aerial is coupled to the three grid coils by special windings and also by "bottom capacity" presented by C18, the A.V.C. decoupling condenser.

V1 is the frequency-changer and the tuned grid oscillator section uses coils

rather similar to those in the aerial. Feed-back from the anode is provided inductively by a winding coupled to L5 on short waves. On medium and long bands feed-back is by making the padding condensers common to both grid and anode circuits.

Trimmer-tuned I.F. transformers link up V2, the I.F. amplifier, and V3, the double diode triode. The two diodes are strapped and the load resistance, R5, provides both A.V.C. and L.F. The latter is passed via C8 to R6, the volume control.

Resistance capacity coupling leads to V4, the output pentode.

High tension is provided by a full-wave rectifier with strapped anodes used in the usual half-wave A.C./D.C. circuit. The speaker field is used for smoothing.

The valve heaters are series run, the voltage being broken down by a ballast valve and a 360 ohm line cord (R4).

Notes.—The coil unit should be removed before any work is done on it. It is removed by taking out two screws at the back left-hand end of the main chassis, two screws on top and then disconnecting the leads from the gang condenser and V1 valveholder.

GANGING

I.F. Circuits.—Inject 465 kc. to the grid of V1 and adjust the I.F. trimmers for maximum. Reduce the input as the circuits come into line to keep below the point at which A.V.C. operates.

S.W. Band.—Tune to 19 m., inject 15.8 mc. to aerial and adjust T1 and T2. Check calibration at 6 mc., and compensate with T1 and T2 if necessary. Padding is fixed (C16).

M.W. Band.—Tune to 200 m., inject 1,500 kc., and adjust T3. Shift signal to 1,400 kc., and adjust T4 for maximum.

Tune to 500 m., inject 600 kc. and adjust T5 while rocking gang slightly.

L.W. Band.—Tune to 1,090 m., inject 275 kc., and adjust T6 and T7. Tune to 1,700 m., inject 175 kc., and pad with T8 while rocking gang slightly.

WINDINGS

L	Ohms.	L	Ohms.
2 ..	.25	8 ..	300
3 ..	1.5	9 ..	17
4 ..	14.5	10 ..	1,500
5 ..	.5	IF1, P & S	3
6 ..	8	IF2, P	16.5
7 ..	1.5	IF2, S ..	15

VALVE VOLTAGES

V	Type	Electrode	Volts
1	6A8G	Anode	150
		Screen	42
		Osc. anode	110
2	6U7G	Cathode	3
		Anode	150
		Screen	42
3	6Q7G	Cathode	2
		Anode	—
4	25A6G	Anode	140
		Screen	150
		Cathode	17
5	25Z6G	Anode	150
		Cathode	250
6	K52H	Ballast tube	—

Pilot lamps, 6-8v., .15 amp.

CONDENSERS

C	Mfds.	C	Mfds.
1 ..	10	11 ..	.1
2 ..	8	12 ..	.05
3 ..	5	13 ..	.1
4 ..	5	14 ..	.0025
5 ..	.1	15 ..	.00012
6 ..	.01	16 ..	.0014
7 ..	.0006	17 ..	.1
8 ..	.01	18 ..	.0024
9 ..	.01	19 ..	.0025
10 ..	.00025		

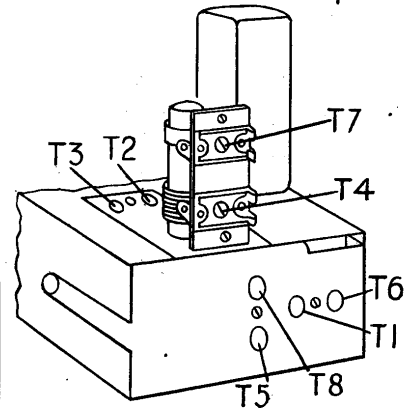

Three bands are covered by this compact receiver and the trimmers are located as shown in this diagram.

RESISTANCES

R	Ohms.	R	Ohms.
1 ..	500	9 ..	25,000
2 ..	10,000	10 ..	10,000
3 ..	50	11 ..	500
4 ..	360 line cord	12 ..	.5 meg.
5 ..	.5 meg.	13 ..	150
6 ..	.5 meg.	14 ..	50
7 ..	.5 meg.	15 ..	.5 meg.
8 ..	.5 meg.	16 ..	25,000

Simple Output Meter

WHEN realigning a receiver an output meter is used to indicate the resonance point. Recently it was found that the meter (a universal type) had smashed and a substitute was required to give an indication of output.

An ordinary 4-volt dial lamp was used with success. It should not be overlooked that in an emergency other points (filament voltages, and so on), could be checked in this simple way.

* * *

In most cases when a speaker speech coil is broken it is just rewound and the speaker re-assembled. Recently I did this, and after a short time the new coil and also the transformer secondary were burnt out, indicating a bad short between primary and secondary windings.

In future, I shall test with an H.T. source of two or three hundred volts between primary and secondary windings before replacing a speech coil.—F. D. L.

