

BELMONT MODEL 500 A.C.-D.C. THREE

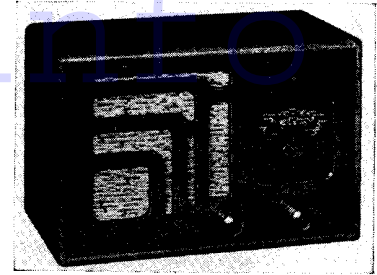

The Belmont 500 is a straight three for universal operation and incorporates a rectifier and a barreter. An interesting feature is that there is no reaction.

CIRCUIT.—The aerial is coupled via an H.F. transformer to the grid of V1, a variable-mu H.F. pentode. A variable resistance in the cathode circuit of V1 varies the amount of bias to the valve and controls the volume. It also reduces the aerial shunt as the bias is increased.

The signal passes to the grid of V2, the detector, also an H.F. pentode, through a tuned secondary H.F. transformer.

It will be noted from the diagram that no reaction circuit is arranged. The general design of the set, however, provides good sensitivity.

The demodulated output of V2 is passed on to V3, an output pentode, by a resistance-capacity network, and thence to the

speaker through the usual matching transformer.

Mains equipment consists of a 2525 rectifier, and the usual smoothing arrangements with a shorting switch providing for 110 volts mains.

Special Notes.—The single dial light is rated at 6.2 volts and consumes .3 ampere. As is usual with universal mains sets, it is connected in series with the valve heaters and mains adjustment resistance.

R1 was found to be 250,000 ohms in our particular chassis. R11 is situated in the mains cord.

Removing Chassis.—Remove the two fixing screws holding the back of the

cabinet in position and the three control knobs, which are fixed by grub screws, from the front of the receiver.

Next turn the set up on one side and remove the three fixing bolts and washers from the base.

VALVE READINGS				
No signal. Volume maximum. 200 volt. A.C. mains.				
V.	Type.	Electrode.	Volts.	Ma.
<i>All Tungstam.</i>				
1	6D6 (6)	Anode ..	65	2.9
		Screen ..	65	*
2	6C6 (6)	Anode ..	18	.05
		Screen ..	10	†
3	43 (6)	Anode ..	62	13.
		Screen ..	10	13.
4	25Z5 (6)	Filament	75	—
				† Negligible.

RESISTANCES		
R.	Purpose.	Ohms.
1	V1 long-wave shunt ..	1 meg.
2	V1 cathode bias (part) ..	500
3	Volume control ..	25,000
4	V2 grid leak ..	3 meg.
5	V3 grid leak ..	75,000
6	V3 cathode bias ..	650
7	V2 screen decoupling ..	6 meg.
8	V2 anode load ..	1 meg.
9	Constant voltage regulator ..	K52H barreter
10	Constant voltage regulator ..	K52H barreter
11	Mains voltage adjustment ..	—

CONDENSERS		
C.	Purpose.	Mfd.
1	Series aerial ..	.0003
2	V1 cathode bias shunt ..	.1
3	V2 grid ..	.005
4	V2 screen decoupling ..	.1
5	H.F. by-pass ..	.0001
6	L.F. coupling ..	.01
7	Pentode compensator ..	.01
8	H.T. smoothing ..	8
9	H.Y. smoothing ..	8
10	Mains filter ..	.05
11	V3 cathode bias shunt ..	5

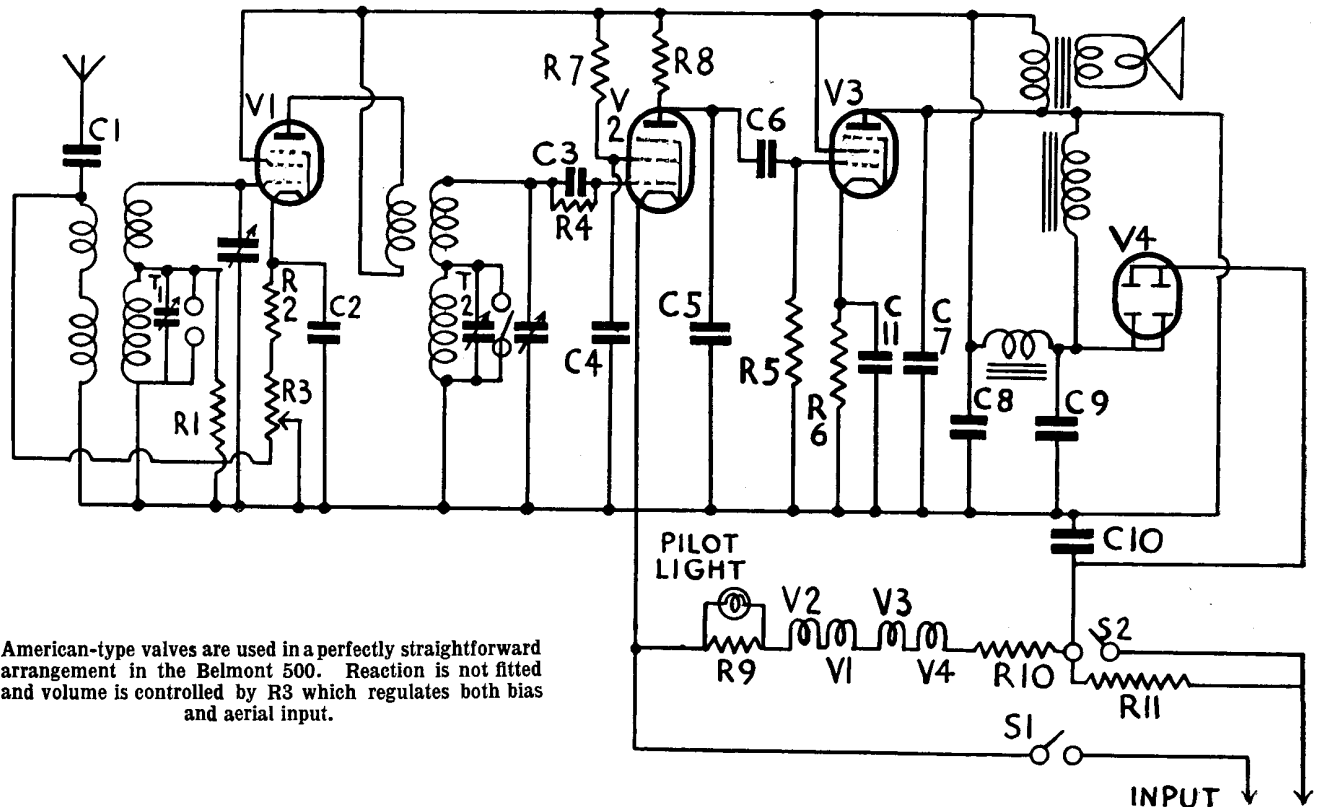

American-type valves are used in a perfectly straightforward arrangement in the Belmont 500. Reaction is not fitted and volume is controlled by R3 which regulates both bias and aerial input.

Circuit Alignment Note

Connect a service oscillator between the aerial input and earth, an output meter being connected to the speaker transformer in the usual manner, and the volume control turned to maximum.

Medium Waves.—Tune the set to 225 metres (1,330 kc.) and inject a signal of 225 metres.

Adjust the trimmers on the sides of the

grid tuning and H.F. stage tuning condensers for maximum volume.

Long Waves.—Tune the set to 1,000 metres (300 kc.) and inject a signal of corresponding wavelength.

Adjust the long wave trimmers, T1 and T2, for maximum strength on the output meter.

A REPLACEMENT condenser block for the Belmont 500, containing Cs 8, 9 and 11, is available from A. H. Hunt, Ltd., of Garratt Lane, Wandsworth, London, S.W.18. List number 2908, it retails at 7s.

Belmont 500 on Test

MODEL 500.—Standard model for A.C. or D.C. mains operation, 200-260 volts, 40-100 cycles, with shorting switch for 100-110 volts working. Price £5 10s.

DESCRIPTION.—Two waveband, miniature table "straight" three without reaction. Universal working with mains resistance in flexible cord.

FEATURES.—Controls for tuning, volume and range selection. Illuminated full vision scale.

LOADING.—65 watts.

Sensitivity and Selectivity
MEDIUM WAVES (200-550 metres).—Sensitivity very good, selectivity reasonable. Best performance with medium aerial in the vicinity of local stations. Large aerial at greater distance gives excellent performance.

LONG WAVES (900-2,000 metres).—Sensitivity sufficient for usual stations. Selectivity satisfactory at reasonable distances from Droitwich.

Acoustic Output
 Sufficient for medium room without overloading. Well corrected output with a pleasing balance.

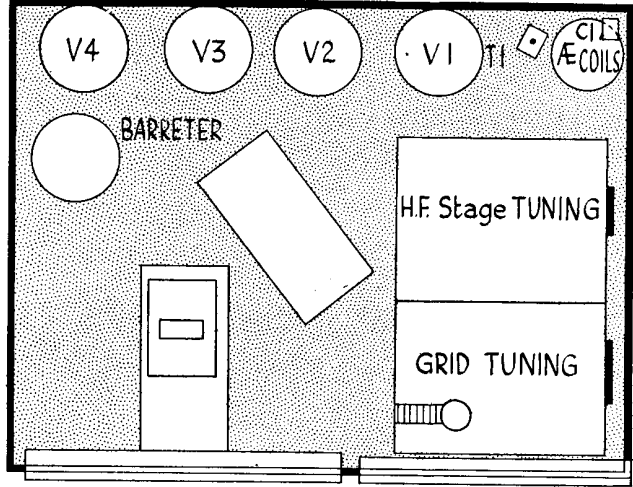

These two diagrams give all practical details of the Belmont chassis. The tinted one shows the top and the other the underside. Resistors are indicated in solid black.

As the above diagram shows, the Belmont chassis is compact and a little unusual in layout. The valves are grouped accessibly along the back and the two-gang condenser is placed at one side.

Right is the underside layout drawing of the Belmont 500 which enables all components and trimmers to be located. Although there is a total of five valves the receiver is basically a simple straight three and its construction is correspondingly straightforward.

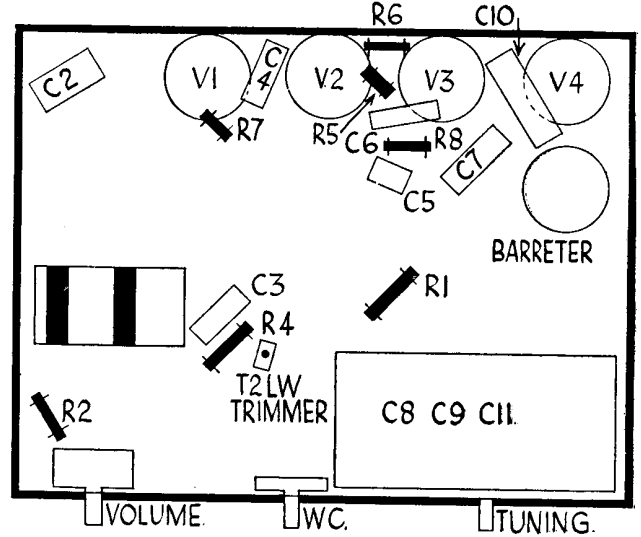

H.F. INSTABILITY IN RECEIVERS WITH A.V.C.

NORMALLY motor-boating is the symptom of L.F. instability, and is the result of insufficient decoupling of L.F. valves. With modern receivers, however, a similar effect is experienced while the cause is H.F. instability.

In a non-A.V.C. receiver H.F. oscillation produces a whistle or "paralysis." Where there is A.V.C., however, the oscillation may be interrupted at the time constant of the A.V.C. system, with the result that a noise like motor-boating will be heard.

What happens is this: The H.F. oscillation builds up a strong signal which is applied to the A.V.C. circuit as if it were a received signal. The A.V.C. circuit

biases the H.F. valves and reduces amplification. Under these new conditions oscillation stops. But at once the A.V.C. bias is reduced, amplification goes up and oscillation commences again. So the process continues, the constants of the A.V.C. circuit regulating the frequency.

Usually this form of trouble is recognizable by the fact that when the receiver is tuned to a strong station the oscillation ceases, the reason being, of course, that the A.V.C. has reduced the gain.

To effect a cure, the causes of the instability must be sought in the R.F. or I.F. stages. The A.V.C. section is, of course, blameless.

H.F. instability is due to unwanted

couplings between circuits. These may be caused by a common impedance or by induction or electrostatic effects between wires and components. If oscillation occurs at higher frequencies it is due to stray couplings; if it appears at the lower frequencies it is caused by a common impedance—in other words, decoupling should be improved.

In difficult cases it is sometimes advisable to tune the set to about 300 metres and by some alteration of electrode voltage—anode, screen or bias—reduce amplification until oscillation ceases. Tuning to higher or lower frequencies will then reintroduce oscillation and so indicate the nature of the cause.