

BEETHOVEN P202 BABY PORTABLE

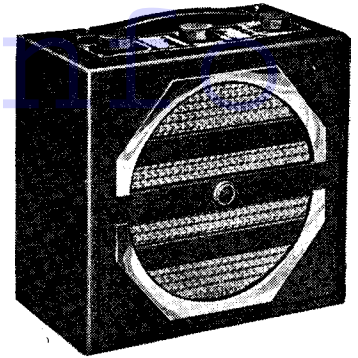

The Beethoven Baby Portable contains a four-valve chassis, a moving-coil speaker and measures only 9 by 8½ by 5 ins. The price is 7 gns.

CIRCUIT.—The self-contained frame aerial constitutes the grid coils of V1, a pentode operating as an H.F. amplifier.

V1 is tuned anode coupled to V2, a triode demodulator, and reaction is obtained from the anode of V2 in conjunction with the anode coils of V1, and is controlled by a variable condenser.

An H.F. filter and anode decoupling circuit effectively decouples the anode of V2. It will be noticed that V2 utilises the grid leak method of detection, and a fixed potentiometer across the filament of V2, consisting of R5 and R6, assures smooth control of reaction.

V2 is resistance capacity coupled to V3, a triode operating as an L.F. amplifier, and V3 in turn is parallel fed auto-transformer coupled to the grid of V4, an output pentode.

Across the primary of the output transformer is connected a pentode compensator condenser C11, that affords a fixed modification of the tone. A grid resistance R10 is included to prevent unstable operation.

Grid bias for the output valve is obtained by a resistance between L.T.

negative and H.T. negative, shunted by a large capacity condenser.

Battery power is supplied by a Sterling 80-volt H.T. battery, with clip contacts, type 2,002, and an Ever-Ready 2-volt jelly-acid accumulator, type J155.

Chassis Removal.—Remove the back of the cabinet, all valves and the batteries. Remove the three grub-screw fixed control knobs, the four wood screws securing the wavelength scale and the chassis-securing bolt, which is revealed by removal of the wavelength scale.

Next remove the two chassis-securing wood screws from the inside of the cabinet, together with the nut holding the chassis bracket, and also unsolder the leads to the contact clips for the H.T. battery.

When replacing the battery leads connect the lead with the yellow systoflex to the positive H.T. clip, and the lead with the black systoflex to the H.T. negative clip.

The chassis may then be lowered, and is available for servicing. For more accessible servicing unsolder the red lead to the tag on the left-hand side of the cabinet.

The speaker may be removed by desoldering the leads to the speaker speech coil and undoing the nuts securing the speaker transformer and the speaker support.

Special Notes.—The indicating light on the front of the cabinet can be replaced by rotating the ruby lens holder as far as it will go to the left, when the glass and holder may be pulled out.

To remove the bulb from the totally enclosed holder hold the milled edge of the lens holder and pull the nut on the reverse end with a pair of pliers. The bulb will then come out.

The bulb is rated at 3.5 volt .3 amp., has an M.E.S. base and is secured in the holder with wax compound to prevent crackles due to the bulb working loose.

The spring clip of the battery should be bent upwards to make firm contact with the clips on the top of the cabinet.

A pair of sockets on the left-hand side of the cabinet permit connections to high-impedance telephones or an extension speaker. A socket on the right-hand side enables an external aerial to be used.

It must be borne in mind that the selectivity of the receiver depends upon the frame aerial, and if an external aerial be used a small fixed condenser should be interposed between aerial and socket.

VALVE READINGS

No signal. No reaction. M.W. band min. cap. New batteries.

V.	Type.	Electrode.	Volts.	Ma.
1	VP2 (7)	Anode ..	65	.8
		Screen ..	70	.4
2	PM2HL (5)	Anode ..	44	.5
3	PM2HL (5)	Anode ..	55	.6
<i>(Above are Mullard)</i>				
4	KT2 (5) Osram	Anode ..	75	3.5
		Screen ..	75	.7

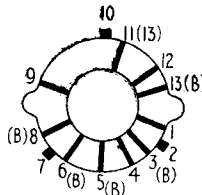

The switch bank with contacts numbered corresponding to the circuit diagram.

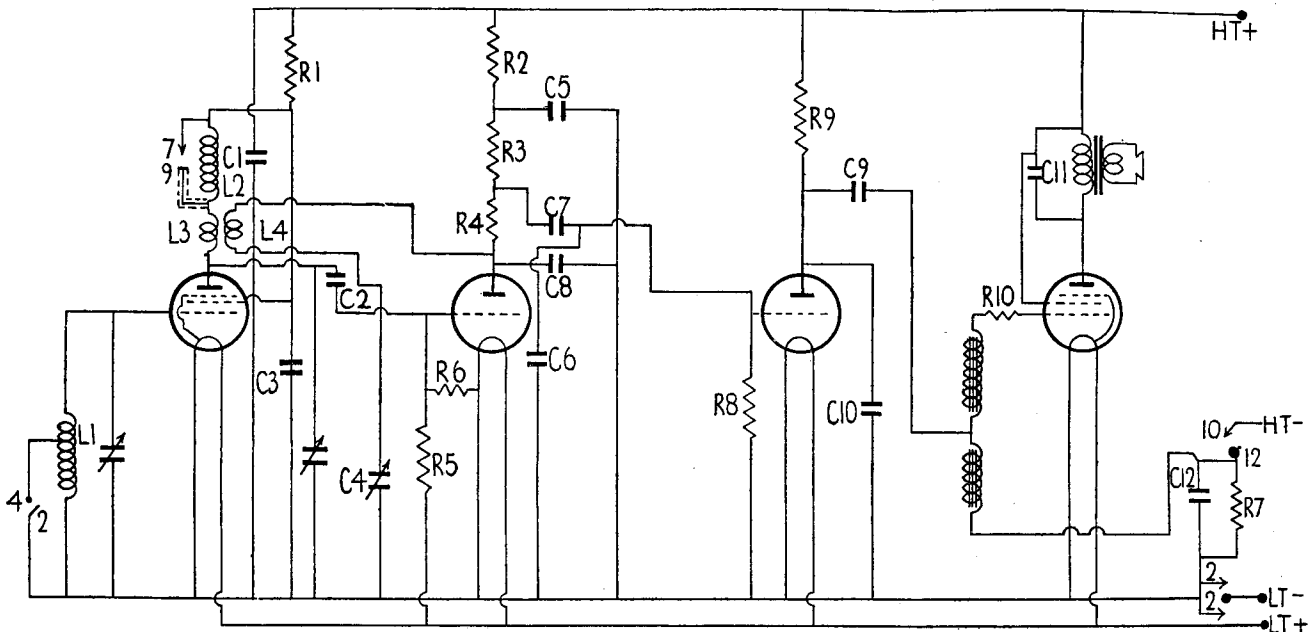

A simple, conventional circuit is employed, the grid coils of the first valve forming the frame aerial. Directional properties of the frame ensure adequate selectivity.

For more information remember
www.savoy-hill.co.uk

Circuit Alignment Notes

Take out the two wood screws from the right-hand side of the cabinet that secure the metal name-plate. Two holes will be found in the space revealed, whereby access to the two trimmers can be obtained.

Connect the leads from a service oscillator to a coupling coil and bring the coil near the receiver. Tune the oscillator to 214 metres (1,400 kc.), and set the receiver wavelength pointer to read 214 metres.

Adjust the lower trimmer to bring in

the signal at maximum volume, and then adjust the top trimmer for maximum.

The reaction condenser (marked volume on the dial) should be adjusted almost to the point of oscillation while the trimmers are being set. Move the coupling coil away from the receiver if the volume becomes too great for accurate ganging and leave the reaction control advanced.

Replacement Condensers

Exact replacement condensers for the P202 are available from A. H. Hunt, Ltd., Garratt Lane, Wandsworth, London, S.W.18.

These are: For C1, unit number 2996, price 2s.; for either C3 or C5, unit 3479, 1s. 9d.; for C12, 2918, 1s. 9d.

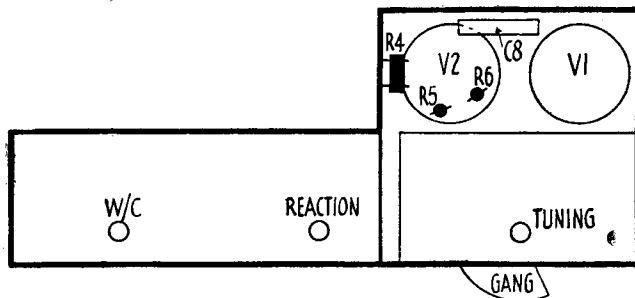

Left, a diagram giving a top view of the Beethoven P202 chassis. A rather unusual form of construction is necessitated by the compact nature of the set.

Right, a side view of the set which shows the positions of the rest of the components and how the two other valves are arranged.

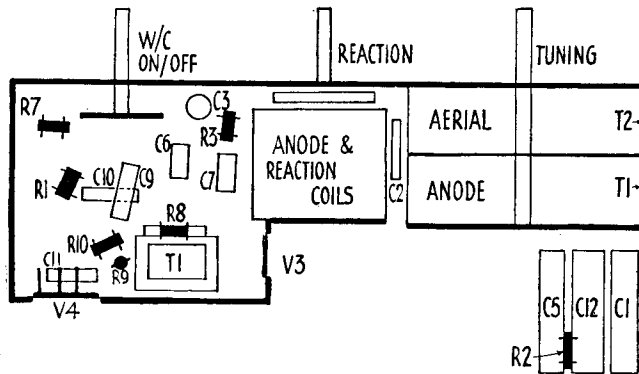

Beethoven P202 on Test

MODEL Baby P202.—For battery operation, requiring a Sterling 80-volt H.T. battery, type 2002, and an Ever Ready 2-volt jelly-acid accumulator, type J155. Price, 7 gns. complete.

DESCRIPTION.—Four-valve, "straight" battery portable covering two wavebands and with self-contained aerial.

FEATURES.—Contained in a leatherette case measuring only 9 by 8½ by 5 in. Carrying strap. Rectangular scale calibrated in metres and station names. Controls for combined wave selection and master switch, reaction and tuning. Pilot light on speaker grill can be switched off to economise L.T. current.

LOADING.—H.T., 6.5 ma.; L.T., .5 amp. or .3 amp, with dial light.

Sensitivity and Selectivity

MEDIUM WAVES (200-550 metres).—Good gain for valve combination and frame aerial employed. In daylight the main stations are easily received. A very good number is obtainable after dark.

LONG WAVES (900-2,000 metres).—Good gain and adequate selectivity. Luxembourg, Radio Paris, Drotwich, and Hilversum are very easily received without any interference. Careful handling of the directional frame and reaction control enables less powerful stations to be obtained.

GENERAL NOTES.—The reaction control is very smooth and free from overlap and apart from a little stiffness in the tuning knob, the set handles excellently on both bands.

Acoustic Output

Clean, crisp tone with sufficient volume for a small room without distortion. Balance is well adjusted and the general reproduction is pleasing.

RESISTANCES

R.	Purpose.	Ohms.
1	V1 screen and anode decoupling	4,000
2	V2 anode decoupling	6,000
3	V2 anode load	30,000
4	V2 anode H.F. filter	6,000
5	V2 grid pot. (part)	4 meg.
6	V2 grid pot. (part)	4 meg.
7	V4 grid bias resistor	300
8	V3 grid leak	500,000
9	V3 anode load	20,000
10	V4 grid stopper	250,000

CONDENSERS

C.	Purpose.	Mfds.
1	H.T. reservoir	4
2	V2 grid00015
3	V1 screen and anode decoupling	2
5	V2 anode decoupling	2
6	H.F. filter004
7	L.F. coupling0025
8	H.F. filter00005
9	L.F. coupling05
10	V3 anode shunt001
11	Pentode compensator004
12	V4 bias resistor shunt	25

H.M.V. 653 Three-band Four

(Continued from page 5)

Medium Waves.—First turn gang to maximum and see that the pointer coincides with the small black spot in the top right-hand corner of the scale.

Set receiver to M.W., volume and tone to maximum and connect oscillator to aerial and earth sockets.

For adjusting the coil cores a special tool must be obtained from E.M.I. Service, Ltd.

Set the receiver (by spot on scale) and oscillator to 225 metres (1,333 kc.). Adjust TC7 for maximum.

Set receiver (by spot on scale) and oscillator to 530 metres (566 kc.). Adjust spade trimmer of L9 for maximum.

Tune set and oscillator to 225 metres and adjust TC2 for maximum.

Tune set and oscillator to 530 metres. Rotate upper core of L6 for maximum by means of special tool.

Readjust at 225 metres.

Long Waves.—Set receiver and oscilla-

tor to 1,100 metres (272.72 kc.) and adjust TC6 for maximum.

Set receiver and oscillator to 1,900 metres (158 kc.) and adjust L10 for maximum.

Repeat all operations with a final check at 1,100 metres. Adjust TC1 for maximum (at 1,100 metres).

Set receiver and oscillator to 1,900 metres and adjust hexagonal headed screw core of L7 for maximum.

Set receiver and oscillator to 1,400 metres (214.3 kc.) and readjust TC1.

Short Waves.—Preferably the oscillator output should terminate in a 100-ohm non-inductive parallel resistance and a 400-ohm non-inductive resistance in series with the "hot" lead.

Set receiver and oscillator to 50 metres (6 megacycles) and adjust the loop in L8 for maximum. A strip of insulating material should be used for this.

Adjust the loop in L3 through hole in top of chassis for maximum.

For more information remember

www.savoy-hill.co.uk

BEETHOVEN P202 BABY PORTABLE

Four-valve TRF battery-operated baby portable covering two wavebands, with self-contained frame aerial. Housed in a leatherette case with carrying strap. Provision is made for an external aerial and speaker. Marketed by Beethoven Electric Equipment Ltd., Chase Road, North Acton, London.

INPUT to the grid of V1, an RF pentode, is via a frame aerial with windings L1 (MW) and L2 (LW) forming the grid coils and tuned on both wavelengths by VC1 section of the ganged condenser. Anode and screen of V1 are fed from the high-tension line through R1 and decoupled by C3. The high-tension reservoir condenser is C1.

Output from V1 is coupled to the triode detector valve V2 by tuned anode coils L3 and L4 tuned by VC2 section of the gang. Reaction is obtained from the anode of V2 by means of the reaction coil L5, coupled to L4, and is controlled by the condenser VC3.

To secure smooth reaction, the grid of V2 is returned to the junction of R5 and R6 across the filament. Grid leak detection is employed with C2 and R5, R6 as grid condenser and leak.

The anode circuit of V2 incorporates an RF filter and decoupling circuit with C7 and R4 as filter and R2, C4 decoupling components. A fixed degree of tone correction is provided by C5.

V2 is resistance-capacity coupled by R3, C6 and R8 to V3, a triode operating as an AF amplifier, and

V3 is coupled through a parallel-fed auto-transformer L6, L7, to the grid of the output pentode V4.

Anode of V3 is fed through R9 from the high-tension line with C9 for high note by-pass. C8 is the AF coupling condenser, and R10 is a grid stopper resistance to prevent parasitic oscillation. Bias is obtained by R7 connected between HT and LT negative, and shunted by C11.

Output transformer L8, L9 couples V4 to the permanent-magnet moving-coil loudspeaker, with fixed tone correction effected by C10 across the primary.

An external speaker of high impedance or phones may be connected to the sockets provided, which are located at the side of the cabinet.

Switching is carried out by a ganged unit, the contacts 2-4 and 7-9 being the waveband switches, and 10-12, 2-2 the battery circuit switches. The pilot lamp, fitted behind a ruby lens on the speaker grill, can be switched off to economise LT current.

Battery power is supplied by a Sterling type 2002, 80 volt HT battery with clip contacts, and an Ever Ready type J155 2 volt jelly acid accumulator. Equivalent batteries are suitable provided they have slip contacts and fit in the cabinet.

GANGING

Take out the two wood screws from the right-hand side of the cabinet that secure the metal nameplate. Two holes will be found whereby access to the two trimmers can be obtained

Connect the leads from a service oscillator to a coupling coil and bring the coil near the receiver. Tune the oscillator to 214m (1,400 kc) and set the receiver scale pointer to 214m.

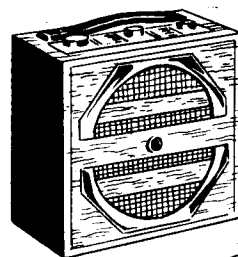

Above: the Beethoven P202 Baby Portable.

Below: the Beethoven P107 Super Minor Portable.

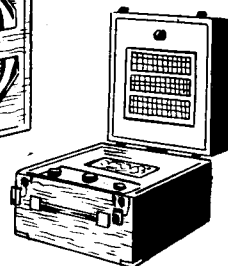

BEETHOVEN P107 SUPER MINOR PORTABLE

Four-valve TRF battery-operated portable covering two wavebands with self-contained frame aerial. Housed in a suitcase type cabinet. Sockets are provided for aerial and earth, and external speaker. Marketed in 1937 by Beethoven Electric Equipment, Ltd., Chase Road, North Acton, London.

THE circuit of the P107 model is so similar to the model P202 reviewed on this page, that a full description of the circuit is not necessary. Where they differ, can easily be detected from the accompanying circuit diagram and component values.

Continued overleaf

The circuit and chassis layouts on this page refer to the popular Beethoven P202.

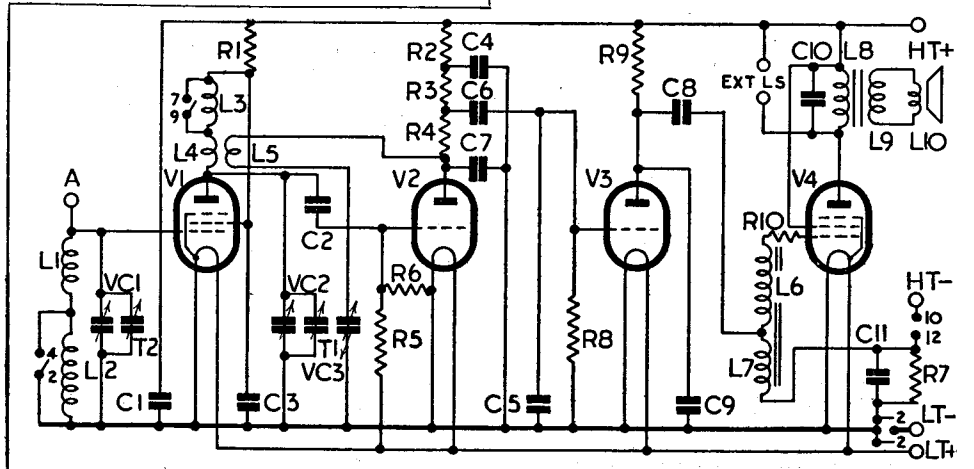
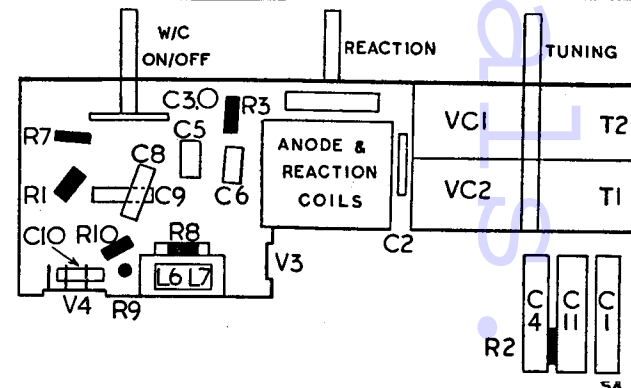
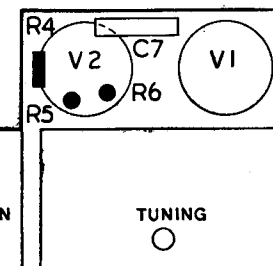

VALVE READINGS

V	Type	Electrode	Volts	Ma
1	Mullard VP2	Anode	65	.8
2	Mullard PM2HL	Screen	70	.4
3	Mullard PM2HL	Anode	44	.5
4	Mullard PM2HL	Anode	55	.6
4	Osram KT2	Anode	75	3.5
		Screen	75	.7

Volts taken with no signal input, no reaction. MW indicating light bulb, Osram MES 3.5v. 3A.

RESISTORS

R	Ohms
1	4,000
2	6,000
3	30,000
4	6,000
5	4 meg
6	4 meg
7	300
8	500,000
9	20,000
10	250,000

CONDENSERS

C	Mfd's
1	4.0
2	.00015
3	2.0
4	2.0
5	.004
6	.0025
7	.00005
8	.05
9	.001
10	.004
11	25.0

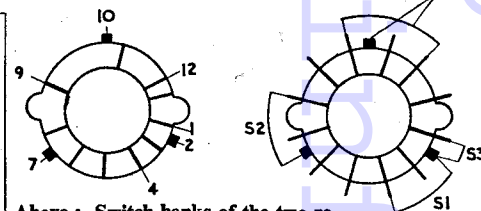

Above: Switch-banks of the two receivers, P202 (left) and P107 (right).

