

HAWKINS ELECTRIC HOSTESS LG1000

The Electric Hostess is a trolley, finished in either toned bronze or ivory and gold, and provided with four two-pint Pyrex food containers with chrome-plated copper lids, a warming compartment, a switch plug for percolator, kettle or toaster, two fold-over table tops and a removable tray. Height is 33½ ins., width 16½ ins., length 28½ ins. and size of top, fully opened, is 42 ins. by 27½ ins. For 200-220V or 230-250V AC/DC and made by L. G. Hawkins and Co., Ltd., 30-35 Drury Lane, London, WC2.



Fig. 1.—The frame is of aluminium tubing, while four ball-bearing, rubber-tyred wheels afford smooth mobility

DESIGNED for use in the home, the Electric Hostess (Fig. 1) is a dumb waiter fitted with an electrically-heated compartment in which food—contained in four two-pint receptacles with copper covers—can be kept hot for several hours, if need be. Plates, up to 12 in number, or pies and tarts can be warmed in a section with drop-down flaps at either end, these having chrome-plated handles.

Two fold-over table tops are also provided, one or both of which can be opened and used, either for eating at or serving from. A removable tray, just above the trolley wheels, can be used to accommodate an electric percolator, kettle or toaster, heated from a 5A three-pin switchplug mounted on heater unit assembly panel (Fig. 2).

Trolley frame is sturdily constructed of aluminium tubing, while the heating compartment, table tops and removable tray, are made up from pressed aluminium sheet. Four ball-bearing, rubber-tyred wheels, 4 in. in diameter and swivelled, afford smooth mobility.

Heater unit assembly and switchplug are mounted on a flat aluminium panel (Fig. 2). Two series-connected 200W 100V first-grade spotted-mica tape-wound elements are employed, together with a 3A single-pole on/off switch and a 5.5V .3A indicator bulb. The latter is mounted behind amber coloured glass and comes into circuit when the elements are switched on, taking its current from a 6V tapping on one of the elements. All metal parts are earthed, and the 12 ft. three-core mains lead is fed into a Grelco terminal block.

The heater unit assembly panel is immediately below the warming compartment and spaced from it by two distance pieces. The food containers are suspended in the compartment on aluminium rails (Fig. 3) and the plates rest on the base, which is perforated. Hot air generated by the heater elements rises through these perforations. With the table tops folded in and the drop-down flaps closed, sufficient heat is conserved to meet requirements without overheating.

Continued on page 6

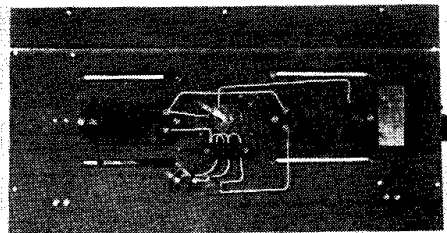

Fig. 2.—Heater unit assembly panel is directly below the warming compartment

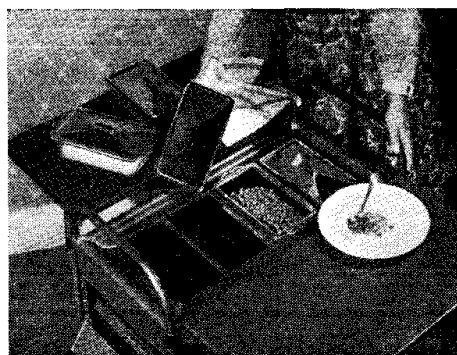

Fig. 3.—Hot air rises through perforations in the bottom of the warming compartment to the food containers suspended on aluminium rails

BSR MONARCH MULTI-SPEED AUTO CHANGER

Price £16 10s. 3d. (£12 10s. plus £4 0s. 3d. tax); date released, March 1953.

The Monarch will play up to eight mixed 10 and 12in. standard 78 rpm records, ten mixed 33½ rpm records, or ten 7in. The changer has a minimum of moving parts. Easy record loading and foolproof speed change and on-off-reject controls—two in all—are provided. The lightweight rotary crystal pickup head incorporates sapphire stylus which can be easily replaced by retailer or user. For 110-120V and 200-250V, 50c/s AC. Manufactured by Birmingham Sound Reproducers Ltd., Claremont Works, Claremont Street, Old Hill, Staffs.

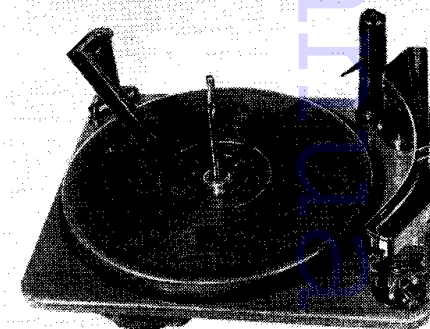

Fig. 1.—Simple control by only two knobs, and economy of design, are two of the features of the versatile Monarch three-speed changer

OF MODERN styling and finished in hammered bronze or cream, the Monarch auto-changer is completely self-contained (Fig. 1). Assembled on a pressed steel baseplate, it requires a minimum cabinet fitting space: 12½in. wide, 10½in. deep, with 5½in. clearance above and 3in. below. The baseplate is fitted with four suspension springs to eliminate acoustic feedback. Pickup arm and base, control knobs and selector cover are of Bakelite; all moving parts of changer mechanism are chemically blacked.

Output from the crystal pickup is .75V at 1,000 c/s, with a frequency range of ±3dB from 25-10,000 c/s when loaded at 2 megohms. Therefore with this loading no compensatory circuits are required. The output should be fed into an impedance of not less than 1 megohm, otherwise the lower frequencies will suffer. The crystal has one sapphire stylus for 78 rpm records and another for use with 33½-45 rpm discs. An engraved rotary knob on the front of pickup head enables the user to easily change from one to the other without error. STD on the knob represents stylus for 78 rpm records, while LP indicates 33½-45 rpm.

Mains voltage adjustment is by means of two shorting links in the Bakelite on/off switch housing on underside of unit (Fig. 3). The correct positioning of the links is shown on the moulded cover, secured by two screws.

To operate the changer, place one or more records of the same speed on the loading spindle (Fig. 2), put slot on control arm (Fig. 2) over spindle, adjust speed control knob, turn engraved knob on pickup head so that the letters required come uppermost, and switch on. A record can be rejected at any time after it has dropped on to the turntable by means of the ON-OFF-REJECT control. A record cannot be repeated unless it is repositioned on the loading spindle.

The heavy 10in. diameter, pressed steel turntable

(with rubber mat) is recessed into the baseplate and, together with the changer mechanism, is driven by a four-pole induction motor. The motor drives the turntable through a spring-loaded, intermediate 2in. rubber-tyred wheel which bears upon its inside rim (Fig. 2). The wheel engages with a three-step drive bush attached to motor spindle. Steps on drive bush provide three different speeds, since, as the engraved speed control knob is turned, a lever connected to it raises or lowers the intermediate drive wheel so that it engages with the smallest diameter step (33½ rpm.), the middle step (45 rpm.) or the largest of the three which provides the fastest speed (78 rpm.).

A pinion gear on turntable hub transmits motive power to main gear 102 (Fig. 3) on underside of baseplate. This gear controls the whole cycle of operations.

The steel loading spindle incorporates a record feed lever and two record keepers. When records are placed on the spindle the feed lever is open and, in conjunction with a shoulder on the spindle, prevents them from dropping to the turntable. When the changer mechanism is put into operation, however, the lever momentarily closes and allows one record to fall. The rest are retained by the keepers which are specially shaped pieces of steel located in the top of the spindle.

Control arm (Fig. 2) serves a double purpose. It prevents records tilting and jamming on the loading spindle and also, through a series of levers, ensures that the mechanism is switched off after the last record has been played.

The spring-loaded selector arm is operated by the

BSR CHANGER—Contd.

record as it drops to the turntable. Its function is to position the pickup arm over the turntable for 10 or 12in. records. It does not operate on 7in. records, since the pickup is automatically adjusted to suit them if the selector arm is not actuated.

PRINCIPLE OF OPERATION

When the ON-OFF-REJECT control knob is set to ON, a lever 62 (Fig.3) attached to it operates the mains switch, and the turntable, driven through the intermediate wheel and the motor spindle, begins to revolve. The lever also moves forward to contact a link 98 (Light friction) coupled to an actuating pawl 100 on main gear 102. One section of this gear is without teeth, and at the beginning of the cycle of operations this is opposite the turntable hub which also has a gear attached.

The action of the lever pushes the actuating pawl forward to engage with a projection on turntable hub. This results in the main gear being impelled forward in an anti-clockwise direction and its teeth engaging with those of the turntable hub.

A cam 106 on the opposite face of main gear now moves the main slide 105 (Fig. 4) outward and away from turntable bearing. Coupled to this slide is a toggle slide 168 (Fig. 3) which in turn is linked to pickup raising and lowering spindle 152. Toggle slide moves forward and pickup arm is lifted off rest pillar. As the pickup spindle rises the smaller of its two springs 136 is compressed. This provides an upward pressure to spindle bracket 143 which locks it to the stop plate 148 (Fig. 4) until later in the cycle when the spindle is lowered.

Still moving outward, the main slide engages with reset pin on spindle bracket and the bracket turns in an anti-clockwise direction, rotating the stop plate to a fully-out position. This ensures that on its inward journey, the pickup will be correctly set for 7, 10 or 12in. records. Guide pin on main slide (now almost at the end of its outward movement) actuates the record feed lever 77 (Fig. 4) on loading spindle through link mechanism 114, 119 (Fig. 3). The lever closes and bottom record drops to turntable. Record keepers prevent other records moving laterally and ensure that only one is released.

As the record falls it operates selector arm 129 (Fig. 4) which, according to how far it is depressed, determines the position to which selector slide 131 can rise. The slide has vertical steps cut in its lower end. These engage with other steps cut horizontally on the stop plate. Each step represents a record size, and since the pickup bracket is locked to the stop plate, the combination of the steps engaged will decide how far out the pickup arm will be positioned before it is lowered on to the record.

Main slide now commences to move towards turntable bearing and releases reset pin on spindle bracket. Stop plate is spring-loaded and both plate and bracket, together with pickup arm, turn inward towards the record. Toggle slide also starts on its inward journey, the pickup spindle is lowered and the pickup comes down on the record.

Tension on spring 136 (Fig. 4) is released, spindle bracket is dis-engaged from stop plate and the pickup is quite free to travel across the record. As the pickup spindle is lowered, however, another spring 139 (on pickup spindle) is compressed; main slide and toggle slide are locked under its pressure, and cam 106, which operates main slide, is located in an indentation on it.

Main gear 102 has now completed a revolution,

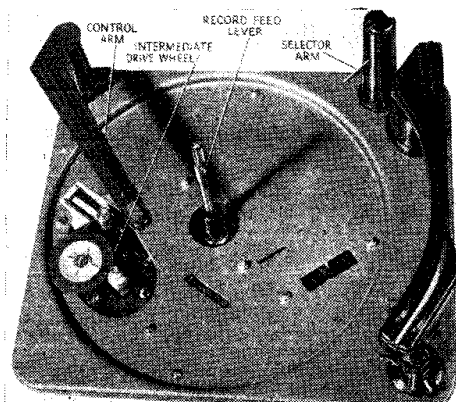

Fig. 2—Top view of changer unit with turntable removed

and while doing so has reset the friction link 98 and actuating pawl 100 against a reset spring 94 which extends over one face of the gear. The main gear is also provided with a ramp form which depresses reset arm 160. This arm is coupled to the selector slide 131 which in turn is pulled down, setting stop plate for 7in. record position. It should be noted that unless the selector arm is operated by a falling record, the pickup will always swing in and come down at the 7in. record position.

Having come full circle, the teeth on main gear have disengaged from gear on turntable hub. Turntable continues to revolve, and the pickup approaches the fast finishing groove on record. As it does so, the spindle bracket slowly turns inward and the reset pin 142 affixed to it pushes lever 96 towards the actuating pawl. As pickup swings forward on the record's eccentric groove, the lever thrusts the pawl against the hub projection, the projection engages with it and main gear is driven anti-clockwise. Pickup spindle rises and the pickup head is lifted off the record. Main slide moves outward away from turntable spindle, contacts reset pin on pickup spindle bracket (again locked to stop plate), and thus the pickup arm is turned back across the record, and, as the spindle is lowered, comes down on the rest pillar.

If there are records on the loading spindle the change cycle begins anew. But after the last record has fallen, the control arm drops to the full down position. Stop arm 167 and stop lever 165 (Fig. 3) come under tension from the spring 12 on stop pawl, and stop arm is positioned directly under stop pin 156. Cut off arm is moved forward into position for engagement with tongue on main gear. Reset arm 160 lifts as gear rotates and stop pin rises to the full extent of its travel.

Main slide would now normally return pickup arm to the record, but as the stop-pin is raised the stop plate is prevented from turning and the pickup remains poised over the stop pillar. The cycle continues, pickup is lowered, and just before the main gear reaches the neutral position, that is, with the cut-away section opposite turntable hub, the tongue on it operates the cut-off arm, which in turn actuates the lever connected to ON-OFF-REJECT switch. Switch is set in the OFF position and motor ceases to operate.

Continued on page 6

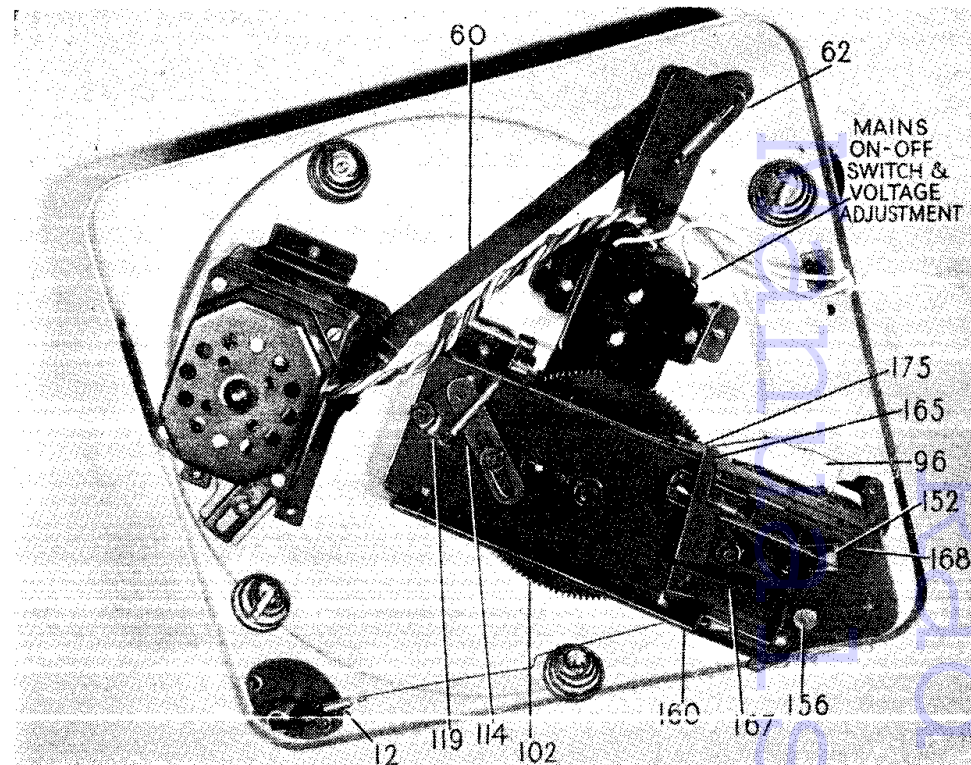

Fig. 3—The mechanism has a minimum of moving parts

Fig. 4—This sub-assembly is secured to the base plate by three screws

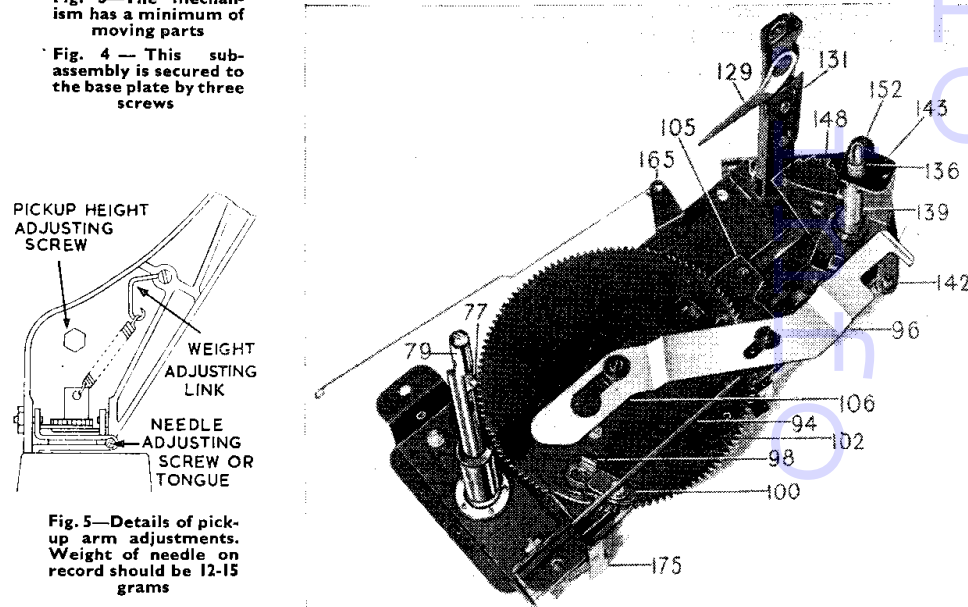

Fig. 5—Details of pickup arm adjustments. Weight of needle on record should be 12-15 grams

FERGUSON—Continued

A means that the core is adjusted from above the chassis and B indicates that adjustment is made on the underside.

IF alignment. Set R4 (Contrast) and R43 (Volume) at maximum. Insert signal-generator between V1 anode and chassis via .01mF capacitors. A short length of coaxial cable should be employed, the bared ends being as short as possible. Care should be taken not to disturb channel tuner unit wiring during this operation. Disconnect R10 at valveholder end of V2B without disturbing C10, which consists of a short length of twin feeder adjusted for optimum tracking over the frequency range covered by tuner.

When adjusting inductance cores two maximum output peaks may be found. In each case the correct peak will be that where core is in the outer position. Proceed as follows: Inject 19.5mc/s, adjust L13 (B) for minimum vision. 19.5mc/s, adjust L23 L24-L25 (B) for maximum sound.

14.5mc/s, adjust L9 (B) for minimum vision. 17.6mc/s, adjust L14-L15 (B) L11 (A) L10 (B) L7 (A) L6 (B) for maximum vision.

The tuned circuits to which L11 L10 L7 L6 are coupled should be shunted with a 1K ohm resistor, e.g. when trimming L11, shunt L10. Conversely when adjusting L10 shunt L11.

Retrim L13 L23 L24 L25. Channel tuner alignment. Disconnect signal-generator from V1 anode and reconnect oscillator anode feed. Connect signal-generator to Direct aerial sockets. It should be noted that the aerial and RF circuits are aligned not to the vision carrier frequency, but to a frequency 1.5mc/s lower. C10, the oscillator trimmer, should not be disturbed.

Set cursor on tuner unit to required channel and inject sound carrier frequency. Adjust oscillator coil L5 for maximum audio output before accurately realigning it. After which L1, image rejector, should be adjusted.

The signal generator should be accurately set before oscillator is tuned. This can be achieved by beating the output with BBC signal. Sound carrier rejection relative to vision carrier should be at least 35dB. The rejection filter is very sharp and care should be exercised when making this measurement. Proceed as follows:

Inject sound carrier frequency and adjust L5 (A) for minimum vision. L1(A) inject 95mc/s adjust for minimum vision. Inject a frequency 1.5mc/s below vision frequency and adjust L3 (A) L4 (A) for maximum vision.

Hawkins Hostess—Contd. from p. 1

DISMANTLING

Heater unit assembly panel is situated underneath the warming compartment. First take out food containers and remove the two red-headed screws positioned on baseplate between the perforations, one in one corner, the other diagonally opposite to it. Remove lower tray and corner support brackets; stand trolley upside down and undo the 10 screws on periphery of heater unit panel. The panel can then be removed.

Heater elements are mounted on porcelain distance pieces, two for each element, through the centres of which pass 2BA bolts, secured by nuts and spring washers. Before these bolts are withdrawn, however, the wires connected to the element terminals should be removed, noting that on the element from which the indicator lamp takes its current, three terminals are provided, instead of the usual two.

Switchplug is mounted on bracket under heater unit panel and can be removed by undoing the two 4BA screws at back.

Indicator glass is held by spring clip which, when released, allows glass to slide out of its metal frame.

Trolley wheel mountings fit into open ends of

tubular frame. By removing two screws in the side of tube, wheel assembly can be withdrawn.

Causes of Interference

THESE two tables show the most frequent causes of interference with sound broadcasting and with television reception, expressed as a percentage of cases reported to the GPO Radio Branch, in the year to January 16, 1953, and considered as closed.

Engineers asked to deal with complaints of interference will find the tables of interest as they can perhaps be regarded as giving the probability factor of the various types of fault. The complete list of all sources of interferences is very much longer.

BROADCASTING		TELEVISION	
Unknown	22.4	Unknown	26.5
Inefficient Ae systems	17.3	Sewing machine motors	18.9
Radiation from T/V timebase	12.1	Faulty receivers	8.1
Faulty receivers	11.2	Hairdryers	7.9
Faulty wiring of buildings	5.1	Inefficient Ae systems	3.5
Sewing machine motors	3.5	Motor car ignition	3.4
Fluorescent tubes	3.4	Motors, miscellaneous	3.1
Refrigerators	2.4	Drills	2.9
Drills	2.1	Vacuum cleaners	2.7
Motors, miscellaneous	2.0	Lamps (filament)	2.3
Bedwarmers	1.7	Fan motors	2.0
Vacuum cleaners	1.4	Overhead power lines	2.0
Overhead power lines	1.2	Refrigerators	1.8
Radio transmitters	1.2	Bedwarmers	1.5
Hairdryers	1.0	Thermostats, miscellaneous	1.4
Smoothing irons	0.9	Radio transmitters	1.3
Neon sign tubes	0.8	Radiation from superhet oscillator	1.2
External cross modulation	0.6	Neon sign tubes	1.2
Sodium lamps	0.6	Medical apparatus (valve)	0.6
Fan motors	0.5	Mis-operation of receivers	0.8
Calculating machines	0.5	Hairclippers	0.7
Generators	0.4	Faulty wiring of buildings	0.6
Dental motors	0.3	Electric toys	0.5
Lamp flashers	0.3	Dental motors	0.5
Washing machines	0.3	Bells	0.5
		Fluorescent tubes	0.3
		Rotary converters	0.3

BUSH AC71

THIS set was brought in with the complaint that Post-Office engineers had located it as a source of interference to neighbouring TV sets.

Shortly after switching on the radio, I observed that the TV set I had placed about three or four feet away had completely blanked out. A few minutes later the picture re-appeared, but fantastically distorted with interference patterns.

By shorting out the various stages in the radio, and observing the effect on the screen, I arrived at an earthing tag, to which were connected earthy end of output valve grid resistor and other earthy leads. Suspecting a poor connection, I removed the nut and bolt and star washer, and replaced same tightening up well.

Still the trouble persisted and the only cure was to run a separate lead from the grid resistor to chassis.—K.U.

MURPHY U144

INTERMITTENT working can often be traced to poor contact between valve pins and valveholder. A little careful "staggering" of the pins proves to be a lasting cure.—E. C.

BSR CHANGER

—Continued from page 2

Once on the turntable a record can be rejected at any stage by use of the REJECT control. Pickup arm is raised and returned to the rest pillar, the next record descends and the cycle of operations begins again. If the record loading spindle is empty, however, pickup is returned to rest and the motor switched off.

ADJUSTMENTS

Needle set down. The set down position of the needle on the records is controlled by the needle-adjusting screw, or bending of the needle-adjusting tongue on certain models (Fig. 5). Adjust the screw or tongue until the correct set down of the needle on a 10in. record is obtained. The correct position is $\frac{1}{16}$ in. from the edge of the record. It is advisable to make this adjustment with a number of 10in. records on the turntable. When correctly positioned for 10in., the 12 and 7in. needle set down will also be correct.

Pickup arm height is adjusted by the pickup height adjusting screw (Fig. 5). To raise the pickup arm, turn screw anti-clockwise; to lower, turn clockwise. Pickup height should be adjusted so that with a 1in. stack of records on the turntable, the point of the needle clears the top record by $\frac{1}{16}$ in. Check that the pickup arm clears the underside of records loaded on the spindle.

Needle pressure should be between 12 and 15 grams. Adjustments may be made by bending the weight adjusting link (Fig. 5) until the correct pressure is obtained.

DISMANTLING

Removing turntable. Remove circlip and lift turntable vertically upwards over centre spindle. Take care not to lose the thin thrust washer, that sticks to underside of turntable boss, ballrace or second thrust washer. Note: Before replacing assembly, set speed control knob to 45rpm. This allows easy manoeuvrability of drive wheel when replacing turntable, without possible danger of bending the arm.

Removing control arm assembly. Hold the sleeve that protrudes from base of control column moulding firmly in a vice, and with a hammer and punch drive the control spindle through the sleeve. On re-assembly, re-riveting can be accomplished by a number of dot punch indentations on the end of spindle around the circumference. This operation should only be undertaken when adequate mechanical facilities are available.

Removing pickup arm assembly. This must be done after the changer has switched itself off. Remove pickup overload spring, unsolder pickup leads from connecting tagstrip. Unscrew pickup top bearing and lift the pickup arm clear. Replace the pickup top bearing to avoid losing the spacer washer.

Removing main sub-assembly. Remove turntable and pickup arm. Uncouple the connecting link from stop pawl spring. Unscrew 2BA bolt at rear of selector cover and also remove bolts on bracket. Main sub-assembly can then be gently removed from unit-plate.

Removing main gear assembly. Remove circlip and actuating lever. Remove circlip from gear bearing. Slacken off 4BA bolt in support bracket and release pawl reset spring from between spring clamp plate and support bracket. Should pawl reset spring be secured by rivet, and not, therefore, easily

removable, it should be flexed out of the way of gear, care being taken not to bend it. Main gear assembly can then be lifted off bearing.

Removing main slide. Remove main gear assembly. Remove circlip and washer, slip record-feed link up and over end of guide pin. Remove washer, circlip and washer. Remove circlip and washer and unhook end of toggle slide return spring from toe of main slide.

Removing pickup cartridge. Turn cartridge round so that 10BA bolt can be unscrewed. Slide out knob. Cartridge should then gently be eased out of its cradle by pressing down against spring. Both spring and pivot are then loose. Slide back the short length of 4mm. PVC sleeving and pull out the two socket tags.

MAINTENANCE

Motor bearings are of the oil retaining type and under normal operating conditions should require little attention.

Occasionally lubricate mechanism as follows: Remove turntable and apply two drops of medium grade oil to bearing; one or two drops to record feed lever; one drop to pickup raising and lowering spindle; two drops to cam under main gear; one drop to stop pin; one drop to control spindle.

Needle replacement. To replace needle hold worn one with a strong pair of tweezers and pull out at an angle of 25 degrees. The new needle should be eased into the needle housing until positioned identically to the needle on the reverse side of the cartridge. Great care should be taken when replacing the needle, as undue pressure might easily damage the crystal.

Note: The changer will not operate correctly unless it is standing level.

POSSIBLE FAULTS AND REMEDIES

If turntable revolves when switch is turned ON, but pickup remains stationary on rest, the knob is not being turned to its fullest extremity in the ON direction. If the knob is jammed and cannot be turned, rotate the turntable by hand clockwise until the fault is cleared.

Turntable will run slow if mains voltage is low, or the frequency is below 50c/s. It may also run slow if the changer has been standing in a cold place. Also check for binding of motor and turntable bearings.

If the last record has been played but the changer does not switch off, check that the control arm has dropped below offset shoulder of loading spindle. Oil if necessary.

Pickup arm striking record on spindle as it rises, or needle catching on record as it moves out, indicates that pickup arm height is incorrectly adjusted.

Changer continuing to cycle with pickup dropping on to record at each cycle indicates that the pawl reset spring is out of position. Adjust reset spring so that it engages with friction link shoulder as main gear is rotated. The spring should not be set too low or it will foul other components. Ensure that the spring fixing bolt is tightened after adjustment.

If pickup merely rises and falls on rest pillar, actuating lever is either jamming on top or slips to wrong side of reset pin.

When changer returns pickup to rest before the last record on loading spindle has dropped, turntable continues to revolve or mechanism is switched off, the stop bracket assembly is wrongly positioned.

Records failing to drop indicates either broken feed spindle in loading spindle, or broken feed lever.