

For more information remember www.savoy-hill.co.uk

# AMBASSADOR 4756

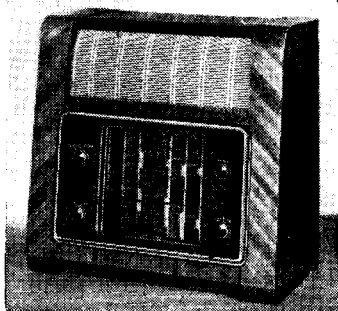

Five-valve, six-waveband superhet with electrical bandspread on short wave ranges. For AC mains, 100-250 volts, 50 c/s, manufactured by R. N. Fitton, Ltd., Brighouse, Yorks.

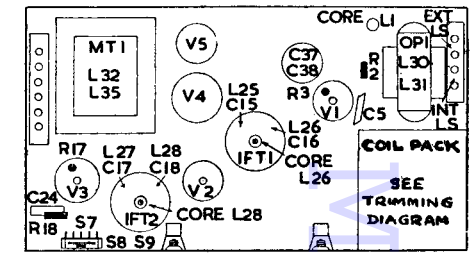
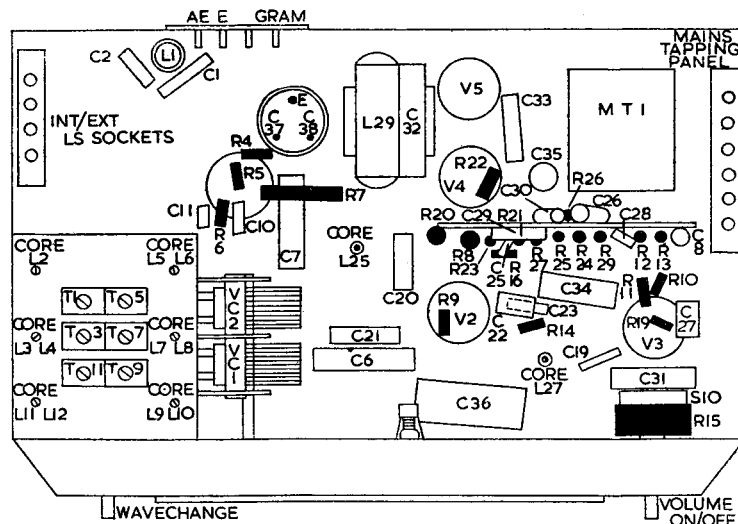

### CAPACITORS

C	Mfjds	Type	C	Mfjds	Type
1	500 pF	Mica	21	.05 Tubular	350V
2	120 pF	Mica	22	120 pF	Mica
3	2400 pF	Silver Mica	23	120 pF	Mica
4	140 pF	Silver Mica	24	.02 Tubular	350V
5	50 pF	Silver Mica	25	60 pF	Silver Mica
6	.1 Tubular	500V	26	.04 Tubular	500V
7	.1 Tubular	500V	27	300 pF	Mica
8	.05 Tubular	350V	28	500 pF	Mica
9	140 pF	Silver Mica	29	.004 Tubular	500V
10	120 pF	Mica	30	.01 Tubular	350V
11	120 pF	Mica	31	.1 Tubular	500V
12	100 pF	Silver Mica	32	.005 Tubular	1000V
13	220 pF	Silver Mica	33	.005 Tubular	1000V
14	625 pF	Silver Mica	34	50	Electrolytic 12V
15	100 pF	Silver Mica	35	50	Electrolytic 12V
16	100 pF	Silver Mica	36	8	Electrolytic 450V
17	140 pF	Silver Mica	37	8	Electrolytic 450V
18	25 pF	Silver Mica	38	8	Electrolytic 540V
20	.05 Tubular	350V	39	30 pF	Silver Mica

### RESISTORS

R	Ohms	Watts	R	Ohms	Watts
1	100 K	1/4 W	16	150 K	1/4 W
2	470 K	1/4 W	17	47 K	1/4 W
3	33	1/4 W	18	4.7 M	1/4 W
4	180	1/4 W	19	1 K	1/4 W
5	47 K	1/4 W	20	3.3 K	1/4 W
6	33	1/4 W	21	150 K	1/4 W
7	22 K	1/4 W	22	47	1/4 W
8	22 K	1/4 W	23	39 K	1/4 W
9	270	1/4 W	24	220 K	1/4 W
10	2.2 M	1/4 W	25	470 K	1/4 W
11	50 K	1/4 W	26	22 K	1/4 W
12	680 K	1/4 W	27	180	1/4 W
13	680 K	1/4 W	28	Not Fitted on Model Tested	
14	47 K	1/4 W	29	47 K	1/4 W
15	500 K	Potentiometer with Switch			

### INDUCTORS

L	Ohms	L	Ohms
1	1.5	17	Very low
2	14	24	Very low
3	11	25	Very low
4	2	28	Very low
5	Very low	29	400
12	Very low	30	270
13	4.5	31	.5
14	.5	32	Very low
15	2.5	33	.375
16	.5	34	Very low
		35	36 total

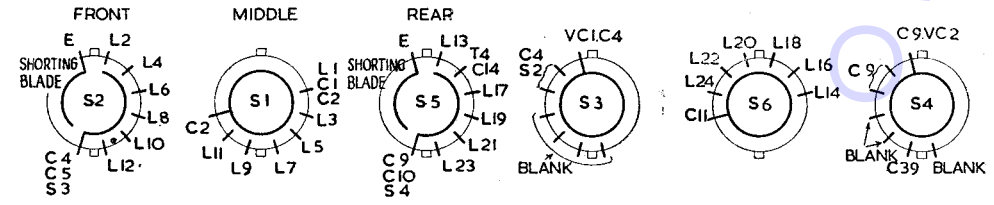
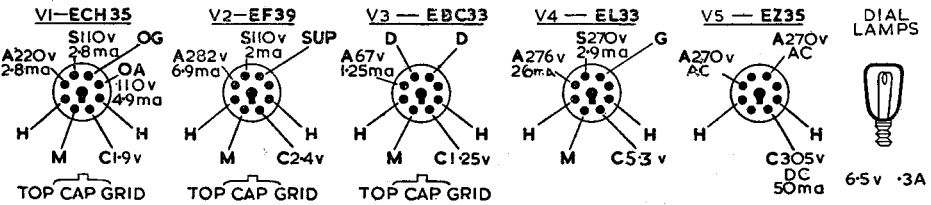
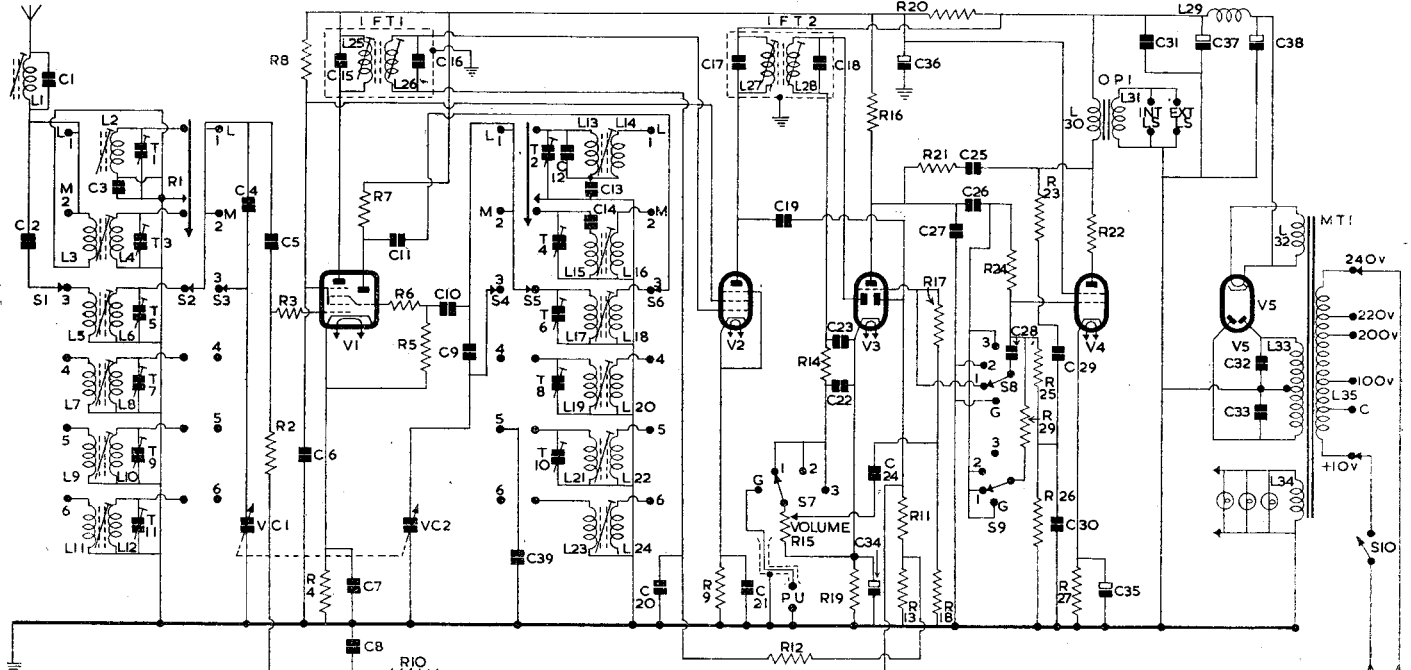

## AMBASSADOR 4756—Contd.

Five-valve six-waveband superhet with electrical bandspread on short-wave ranges and negative feedback tone control circuit. Fitted with sockets for extension loudspeaker and pick-up. For AC mains, 100-250 volts, 50 c/s. Manufactured by R. N. Fitton, Ltd., Brighouse, Yorks.

**CIRCUIT** consists of a triode-hexode frequency-changer V1 coupled by permeability-tuned IF transformer to a variable-mu pentode IF amplifier V2. A second iron-cored IF transformer couples V2 to a double-diode triode V3, which is used for signal rectification, AVC, and AF amplification.

V3 is resistance-capacity coupled to pentode output valve V4. A negative-feedback tone control circuit is connected between V3 and V4. Output valve V4 feeds into an 8-in. PM speaker. HT is provided by an indirectly heated, full-wave rectifier V5.

Aerial is connected through filter circuit L1, C1 to contacts on S1. On LW (Range 1), aerial input is fed through MW coupling coil L3 to bottom end of LW tuned coil L2. C3, R1 are bottom-end coupling components.

On MW (Range 2) aerial is inductively coupled by L3 to tuned coil L4. A series capacitor, C2, is connected in the aerial lead when on the SW bands (Ranges 3, 4, 5 and 6). This capacitor is shorted out by S1 when on Ranges 1 and 2.

L5, L7, L9, L11 are SW aerial coupling coils, L6, L8, L10, L12 are tuned coils, and T1, T3, T5, T7, T9, T11 are trimmers.

S2 connects the tuned circuits across the grid tuning capacitor VC1 and through capacitor C5 and grid stopper R3 to grid V1. A following shorting blade on S2 short circuits the unswitched tuned coils.

C4 reduces the capacity of VC1 when on SW ranges and together with the special coils used produces the bandspread tuning, which is a feature of this receiver. S3 shorts C4 on L and MW.

AVC is applied to grid V1 on all ranges through R2. R10, C8 are decoupling components. Cathode bias for V1 is by R4, C7. Screen voltage is obtained from R8 decoupled by C6. L25, C15, the primary of IFT1, are in V1 anode circuit.

**Oscillator** uses a tuned-grid and parallel-fed HT circuit. S5 selects the tuned coils L13, L15, L17, L19, L21, L23 to oscillator grid via C10 and stopper resistor R6. VC2 is oscillator tuning capacitor, and T2, T4, T6, T8, T10 are trimmers. C12 gives additional capacity across LW coil L13; C13 is fixed padder. C14 is MW padder connected to

the grid side of the coil. No padders are provided for the four SW ranges.

Series capacitor C9 reduces the capacity of VC2 when on SW ranges. S4 short circuits C9 when on LW and MW ranges and introduces a small parallel capacitor C39 across VC2 on Range 5. A following blade on S5 short circuits the unswitched tuned coils.

S6 switches the inductively coupled reaction coils to the oscillator anode through capacitor C11.

IF amplifier operates at a frequency of 465 kc/s. L26, C16, the secondary of IFT1, feeds signal to grid V2, a variable-mu pentode.

Continued on page viii

### TRIMMING INSTRUCTIONS

Apply signal as stated below	Tune receiver to	Trim in order stated for maximum output
(1) 465 Kc/s to top cap V1 via .01 capacitor	—	Core L28, L27, L26, L25
(2) 250 Kc/s to AE socket via dummy aerial	1,200 metres	T2, T1
(3) 158 Kc/s, as above	1,899 metres	Core L13, L2, Repeat (2) & (3)
(4) 1.33 Mc/s, as above	258 metres	T4, T3
(5) 600 Kc/s, as above	500 metres	Core L15, L4, Repeat (4) & (5)
(6) 8 Mc/s, as above	37.5 metres	T6, T5
(7) 6 Mc/s, as above	50 metres	Core L17, L6, Repeat (6) & (7)
(8) 13 Mc/s, as above	23 metres	T8, T7
(9) 9.5 Mc/s, as above	31.5 metres	Core L19, L8, Repeat (8) & (9)
(10) 20 Mc/s, as above	15 metres	T10, T9
(11) 15 Mc/s, as above	20 metres	Core L21, L10, Repeat (10) & (11)
(12) 26 Mc/s, as above	11.5 metres	T11 *
(13) 22 Mc/s, as above	13.65 metres	Core L23, L12, Repeat (12) & (13)

NOTE.—Alignment to be carried out with tone control in position 2 and volume control at max.

\* No OSC trimmer is fitted on range 6 and OSC frequency is lower than signal frequency.

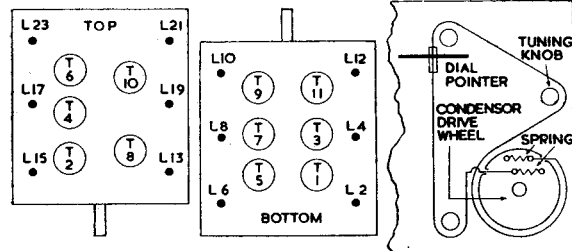
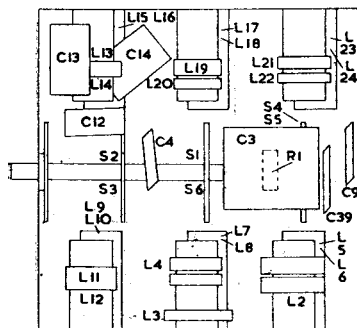

Left, details of coil unit. Centre, trimmer positions. Right, dial drive

# PIFCO

Immediate delivery

METERS at PRICES BELOW PRESENT DAY COST

Panel-mounting moving-coil meter illustrated is in Black Bakelite case, 2 1/4" x 1 1/2". 0-40 volts.

Also available are:

Voltmeter 2 1/4" x 1 1/2" 0-20 Volts.  
 Voltmeter 2 1/8" x 1 1/2" 0-600 Volts.  
 Milliammeter 3" x 1 1/4" 0-50 M.A.  
 Milliammeter 1 1/2" x 1 3/8" 0-75 M.A.  
 Ammeter 2 1/4" x 1 7/8" 50-0-50 Amp.  
 Oil Pressure Gauge 2 1/4" x 2 1/2" 0-160 lbs.

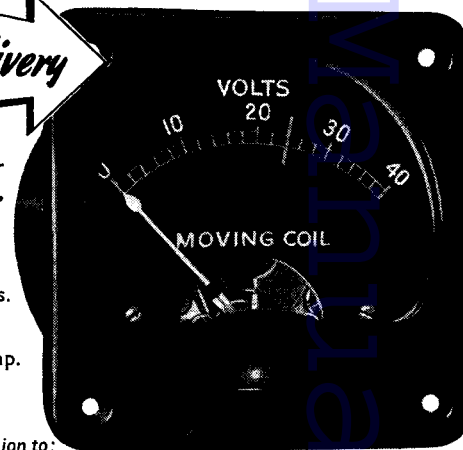

Illustrated folder and trade prices on application to:

PIFCO LTD. · PIFCO HOUSE · WATLING ST. · MANCHESTER, 4

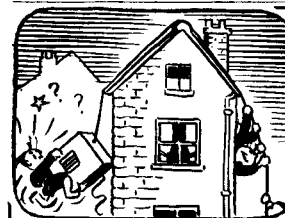

"Heave-ho on that aerial, son! We'll FLUXITE this joint, then we're done. Something's wrong I declare It's got caught up somewhere The darn thing weighs nigh on a ton!"

For all SOLDERING work you need FLUXITE—the paste flux—with which even dirty metals are soldered and "tinned." For the jointing of lead—without solder and the "running" of white metal bearings—without "finning" the bearing. It is suitable for ALL METALS—excepting Aluminium—and can be used with safety on Electrical and other sensitive apparatus. With FLUXITE, joints can be "wiped" successfully that are impossible by any other method. OF ALL IRONMONGERS, in tins—10d., 1/6 & 3/- Used for over 40 years in Government works and by leading Engineers and Manufacturers. "The FLUXITE GUN" puts Fluxite where you want it by a simple pressure. Price 1/6 or filled 2/6.

## FLUXITE

SIMPLIFIES ALL SOLDERING

Write for Leaflets on Case-Hardening Steel and Tempering Tools with FLUXITE, also on "wiped" joints. Price 1d. each. FLUXITE LTD., (Dept. T.E.), Bermondsey St., London, S.E.1.

FOR ALL TIME  
**STURDY**  
 REWINDS  
 SATISFACTION

Send your rewinds to Sturdy. All makes Radio Mains Transformers, Field Coils, etc. First-class work with quick delivery and fully guaranteed.

STURDY ELECTRIC CO., LTD.  
 DIPTON Tel.: DIPTON 221 NEWCASTLE-ON-TYNE

## COLLARO MICROGRAM

—Continued

R14, R13, C13, C14 provide resistance-capacitance smoothing of the HT supply and C9 is fitted to eliminate modulation hum.

Heaters of V1 to V3 are series connected and obtain their current from the mains through tapped voltage dropper resistor R15. R15 is tapped for input mains voltage of 100-125 and 200-250V AC. S1, which is ganged to the volume control R1, is the amplifier on/off switch.

**Removal of motorboard and amplifier.** Secure tone arm of pick-up to its rest arm by means of a piece of wire or string. Remove spring collar from retaining groove on turntable and carefully remove turntable.

Remove the eight roundhead wood screws along sides of motorboard. Gently ease up one edge of motorboard and then lift sufficiently clear of case to be able to unplug the lead to the loudspeaker situated on the left-hand side of case. Motorboard can now be removed.

**Automatic stop mechanism.** The pick-up, while travelling across the record, moves the operating lever O, which in turn makes lever L approach the main spindle. Striker S checks this movement by knocking lever L back at every revolution, until the run-off groove is reached, when the greater movement of lever L causes pawl P to drop off slide A. The next revolution of the striker actuates the stop by operating trigger T.

If the stop operates before the end of a record adjust screw R so that pawl P has a greater overlap.

**Adjustment of stop.** Load the stop by pulling the brake pad towards centre until trigger T snaps in. Turn striker S to the position shown in the diagram and place the lever L in contact with it.

Loosen the locking screw H, push the pawl P to the left with the left hand and adjust the slide A by means of its adjusting screw R so that the pawl P, when again released, rests on the edge of the slide and overlaps it by about 1/64 in., as shown in the drawing. Finally, tighten the locking screw H.

## AMBASSADOR 4756

—Continued from page vi

Cathode bias is from R9, C21 and screen voltage for V2 and V1 is obtained from R8, C6. L27, C17, the primary of IFT2, is in V2 anode circuit.

**Signal rectifier.** L28, C18, IFT2 secondary, apply signal to one diode of V3. Volume control R15 is load resistor. R14, C22, C23 form an IF filter. S7 switches volume control from radio input to PU socket.

**Automatic volume control.** C19 feeds signal from anode V2 to second diode V3. R11, R13 form the load. Full AVC, decoupled by R10, C8, is applied to grid V1. Approximately two-thirds of the AVC voltage decoupled by R12, C20, is fed to grid of V2. Delay voltage is developed across cathode bias resistor R19.

**AF amplifier.** C24 feeds signal from volume control R15, through grid stopper R17, to grid of triode section V3. R18 is grid resistor and cathode bias for triode is developed by R19, C34. R16 is anode load resistor and C27 is HF bypass.

**Output stage.** Signal is fed by C26 to grid V4, pentode output valve. R25, R26 form the grid resistor. Cathode bias developed across R27 is decoupled by C35. Screen voltage comes from R20, C36.

L30, primary of OP1, the output matching transformer, is in the anode circuit of V4 with R22 as anode stopper.

L31, the OP1 secondary, is provided with two sets of output sockets; one set for the internal loudspeaker and the other for an external loudspeaker of low-impedance type.

**Negative feedback and tone control.** R21, C25 introduce negative feedback from the anode of V4 to its grid, via the coupling capacitor C26. Position 1 of S7-8-9 connects capacitor C28 between grids of V3 and V4, and at the same time shunts R29 across R24. This gives treble attenuation at about 3,000 c/s.

In position 2, R29 is still shunted across R24, but C28 is now connected across the grid resistors R25, R26 to earth. This gives a nicely balanced response for normal listening.

In position 3, C28 is connected across R24 and R29 is disconnected from across R24. The effect of this is to give both bass and treble lift, the bass lift being to compensate for transformer and baffle losses, and the treble lift to overcome the dip in the overall selectivity curve of the receiver.

A secondary feedback network consisting of R23, C29 is used to counteract phase shift introduced by the main feedback circuit. When S7 and S8 are in the gram position, conditions are the same as in position 2.

**High tension** is supplied by an indirectly heated full-wave rectifier V5. L33, the HT secondary of MT1, the mains input transformer, provides the anode voltages for the rectifier. C32, C33 are fitted to eliminate modulation hum. L32 supplies V5 heater voltage.

In latest models of this receiver an EZ35 rectifier is fitted. This valve has an isolated cathode and a 6.3 volt heater. The heater voltage is obtained from the same secondary as that supplying heaters of V1 to V4. L29, C37, C38 provide choke-capacity smoothing of the HT supply. In addition, R20, C36 provide further smoothing of the HT supply to anodes V1, V3 and screens V1, V2. V2 anode is supplied from main HT line. C31 provides HF decoupling for HT supply.

**Heaters of V1 to V4 and dial lamps** are supplied by L34. In some models L34 also supplies heater voltage to the rectifier (EZ35).

The primary L35 of MT1 is tapped for 100 to 250 volts, 50 c/s. S10, ganged to the volume control, is on/off switch.

**Removal of chassis.** Remove the four control knobs and back panel of cabinet. Unplug LS from sockets at left hand side of chassis. Unfasten and remove four chassis retaining bolts on underside of cabinet. Chassis can be withdrawn.

**Replacement of cord drive.** The glass station name plate must be removed. It is held in place by four corner clips, which, when unfastened, allow the dial plate to be removed. If necessary, the metal cover plate over the condenser drive wheel may be removed by unfastening the two screws at the top edge.

## COSSOR 470AC

A. C. Cossor, Ltd., state that certain figures relating to production models of their 470AC receiver differ from those published in February SERVICE CHARTS. The anode current of OM10 is 3mA, the resistance of L8 is 8 ohms, and of L12 is 26 ohms. The pilot lamp rating is, of course, 0.3A, not 3A as printed, and the resistance of the HT secondary is 125 ohms.

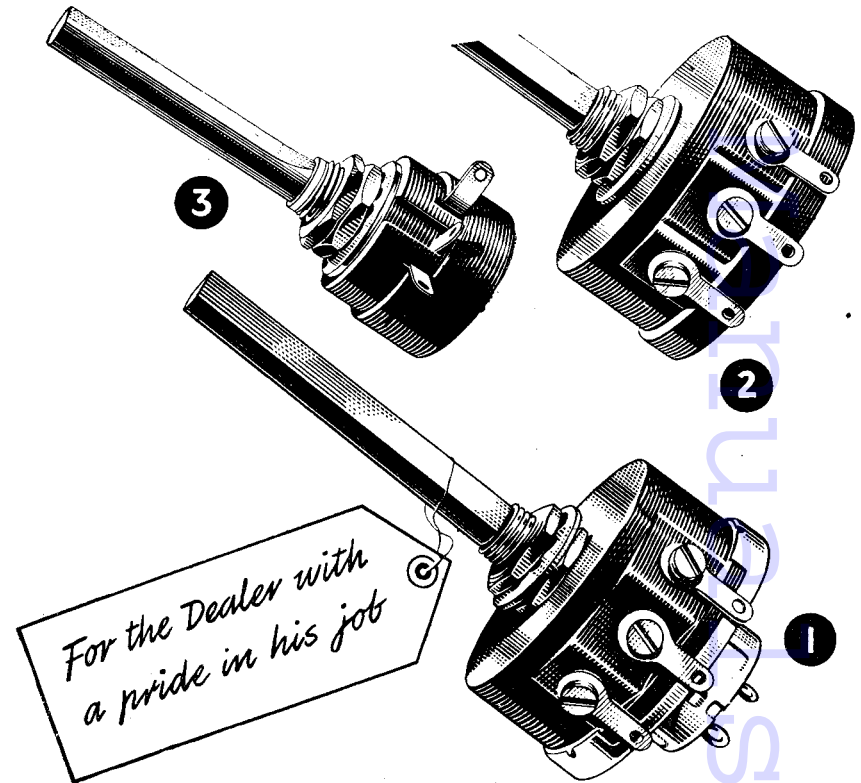

### RADIOSPARES WIRE-WOUND VOLUME CONTROLS

Fitted with SPST switch, 3 watt type, fitted 1/2" flat spindle of 2" free length—illustrated (1) above. Available in following values: 250Ω 500Ω 1,000Ω 2,500Ω 5,000Ω 10,000Ω 15,000Ω 20,000Ω 25,000Ω 35,000Ω 50,000Ω. All at a nett trade price of 5/3 each.

Identical control, less switch, 3 watt type, fitted 1/2" flat spindle of 2" free length—illustrated (2) above (one-quarter enlarged). Available in following values:— 1,000Ω 2,500Ω 5,000Ω 10,000Ω 15,000Ω 20,000Ω 25,000Ω 35,000Ω 50,000Ω. All at a nett trade price of 4/- each.

### RADIOSPARES EXTENSION LOUDSPEAKER VOLUME CONTROLS

Wire-wound, fitted 3/4" flat spindles of 1 1/2" free length—illustrated (3) above.

Available in the following values:

25Ω 50Ω

All at a nett trade price of 3/6 each.

These goods are available as and when listed in our current bulletin only. All these guaranteed quality components are obtainable only direct from

# Radiospares Ltd.

19-23 FITZROY STREET, LONDON, W.1  
Telegrams: Radosperes, Wesdo, London.

Telephone: MUSEum 9301/6  
Cables: Radosperes, London