

"TRADER" SERVICE SHEET

1161

# BUSH DAC90A

Transportable A.C./D.C. Superhet

**H**OUSED in either a cream or a brown plastic cabinet, the Bush DAC90A is a 4-valve (plus rectifier) 2-band transportable superhet designed to operate from A.C. or D.C. mains of 200-250 V, 40-100 c/s in the case of A.C. The waveband ranges are 187-560 m and 1,070-1,900 m.

An earlier version of the DAC90A, model DAC90, is covered in *Service Sheet* 950 and is easily identified by its tuning scale, which is lighter in colour, and by its waveband control, which is positioned half-way up the cabinet side instead of at its lower edge as in the DAC90A.

Release date and original prices: February 1950, £12 1s 8d (brown); £12 16s 9d (cream). P.T. extra.

**CIRCUIT DESCRIPTION**

Tuned frame aerial inputs **L2**, **C25** (M.W.) and **L1**, **L2**, **C25** (L.W.) precede triode hexode valve (**V1**, Mullard UCH42) operating as frequency changer with internal coupling. **S1** closes to short-circuit **L1** for M.W. operation.

Single oscillator grid coil **L3** is tuned by **C26** and is used on both wavebands. Parallel trimming by **C28** (M.W.) and **C8**, **C27**, **C28** (L.W.); series tracking by **C7** (M.W. and L.W.). Reaction coupling from oscillator anode by **L4**.

Second valve (**V2**, Mullard UF41) is a

variable-mu R.F. pentode operating as intermediate frequency amplifier with tuned transformer couplings **C3**, **L5**, **L6**, **C4** and **C11**, **L7**, **L8**, **C12**.

Intermediate frequency 465 kc/s.

Diode signal detector is part of double diode triode valve (**V3**, Mullard UBC41).

(Continued col. 1 overleaf)



Appearance of the Bush DAC90A

**COMPONENTS AND VALUES**

CAPACITORS		Values	Locations
C1	A.G.C. decoupling	0.05µF	G3
C2	L.W. aerial trim ...	130pF	H4
C3	1st I.F. trans	110pF	R2
C4		tuning	110pF
C5	V1 cath. by-pass	0.05µF	G3
C6	V1 osc. C.G.	50pF	G4
C7	Osc. tracker ...	605pF	H4
C8	L.W. osc. trim. ...	515pF	H4
C9	A.G.C. decoupling	0.05µF	F3
C10	H.T. decoupling	0.05µF	G3
C11	2nd I.F. trans.	110pF	C2
C12		tuning	110pF
C13	I.F. by-pass	100pF	F4
C14	A.G.C. coupling ...	50pF	F4
C15	A.F. coupling	0.01µF	F3
C16	V3 cath. by-pass	0.05µF	F3
C17	Tone corrector ...	0.003µF	F3
C18	A.F. coupling	0.01µF	E3
C19	Tone corrector	0.01µF	D1
C20*	H.T. smoothing	32µF	B1
C21*		16µF	B1
C22†	Mains R.F. by-pass	0.1µF	D1
C23†	L.W. aerial trim. ...	40pF	G4
C24†	M.W. aerial trim. ...	40pF	G4
C25†	Aerial tuning	528pF	A2
C26†	Oscillator tuning	528pF	A2
C27†	L.W. osc. trim. ...	40pF	G4
C28†	M.W. osc. trim. ...	40pF	G4

RESISTORS		Values	Locations
R1	A.G.C. decoupling	1MΩ	F3
R2	V1 G.B. ...	220Ω	G3
R3	V1 osc. C.G.	47kΩ	G4
R4	A.G.C. decoupling	2.2MΩ	F3
R5	H.T. feed ...	12kΩ	G3
R6	V2, V3, G.B. ...	330Ω	F3
R7	Volume control	500kΩ	E3
R8	V3 C.G. ...	2.2MΩ	F8
R9	V3 C.G. stopper	100kΩ	F4
R10	V3 anode load	150kΩ	F3
R11	A.G.C. diode load	1MΩ	F3
R12	V4 C.G. ...	470kΩ	E4
R13	V4 C.G. stopper	47kΩ	E4
R14	V4 G.B. ...	150Ω	E4
R15	H.T. smoothing	10kΩ	D2
R16	V5 surge limiter	250Ω	C2
R17	Heater ballast	1.250Ω†	D1
R18	Scale lamp shunt	75Ω	C2

\*Electrolytic. † Variable. ‡ Pre-set.

† Tapped at 950Ω + 150Ω + 150Ω.

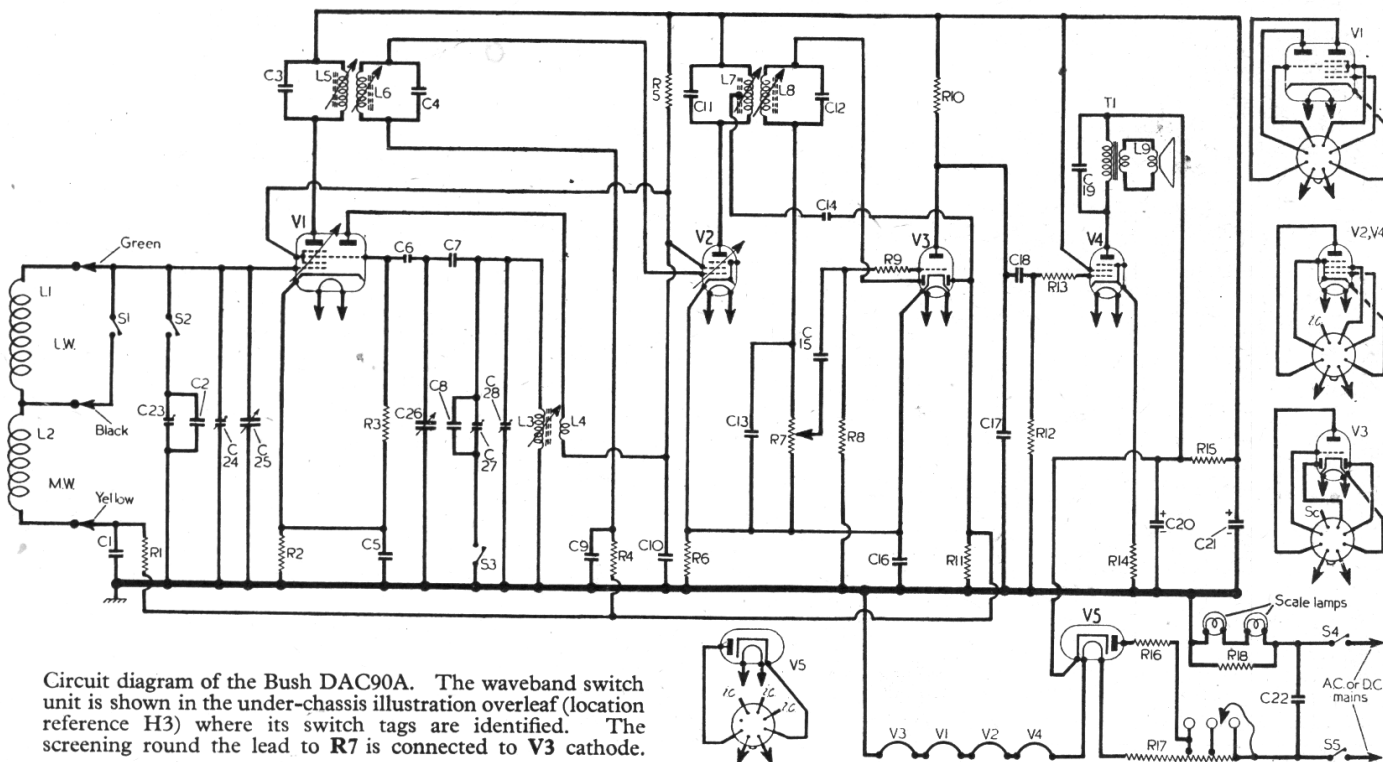

Circuit diagram of the Bush DAC90A. The waveband switch unit is shown in the under-chassis illustration overleaf (location reference H3) where its switch tags are identified. The screening round the lead to **R7** is connected to **V3** cathode.

OTHER COMPONENTS		Approx. Values (ohms)	Locations
L1	L.W. frame aerial	3-25	A2
L2	M.W. frame aerial	3-25	A1
L3	Osc. tuning coil ...	1-5	H4
L4	Osc. reaction coil ...	1-0	H4
L5	1st I.F. trans.	Pri. 12-5	B2
L6		Sec. 12-5	B2
L7	2nd I.F. trans.	Pri. 12-5	C2
L8		Sec. 12-5	C2
L9	Speech coil	3-0	—
T1	O.P. trans.	Pri. 500-0	D1
		Sec. 0-75	—
S1-S3	Waveband switches	—	H3
S4, S5	Mains sw., g'd R7...	—	E3

**Circuit Description—continued**

Audio frequency component in its rectified output is developed across volume control **R7**, which also acts as diode load, and is passed via **C15** to grid of triode section.

Second diode of **V3**, fed via **C14** from a tapping on **L7**, provides a D.C. potential which is developed across **R11** and fed back as bias to **V1** and **V2**, giving automatic gain control. Delay voltage, together with bias for **V2** and **V3**, is developed across **R6**.

Resistance-capacitance coupling by **R10**, **C18** and **R12** between **V3** and pentode output valve (**V4**, Mullard UL41). Fixed tone correction by **C19** in **V4** anode circuit, and by the negative feed-back introduced by omitting the normal by-pass capacitor in **V4** cathode circuit.

H.T. current is supplied by I.H.C. half-wave rectifying valve (**V5**, Mullard UY41). Smoothing by **R15** and electrolytic capacitors **C20**, **C21**. Valve heaters, together with scale lamps and ballast resistor **R17**, are connected in series across the mains input. Mains R.F. filtering by **C22**.

**GENERAL NOTES**

**Switches.**—S1-S3 are the waveband switches, ganged in a single rotary unit beneath the chassis. This is shown in detail in our under-chassis illustration. In the M.W. position (control knob anti-clockwise) S1 closes; in the L.W. position, S2 and S3 close.

**Scale Lamps.**—These are rated at 3.5 V, 0.15 A. They have small, clear, spherical bulbs and M.E.S. bases.

**Tuning Drive Replacement.**—About 3½ feet of nylon braided glass yarn is required for a new drive cord which should be run as indicated in the sketch in column 2.

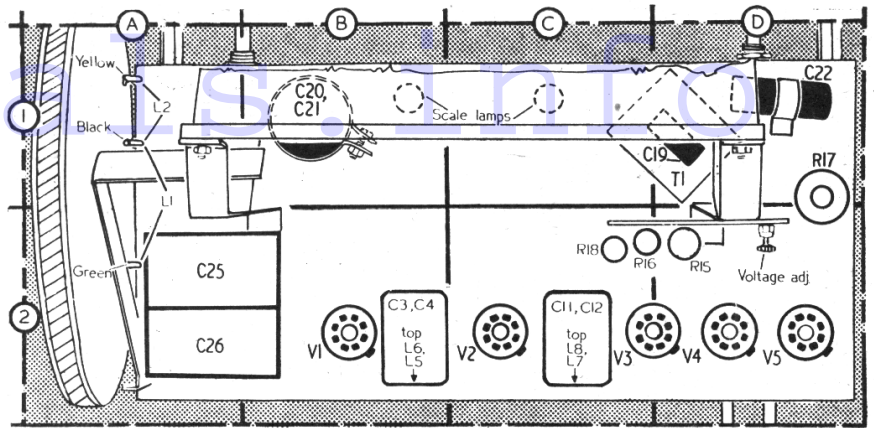

Plan view of the chassis, showing the colour-coded frame aerial connections.

**CIRCUIT ALIGNMENT**

Access to all the I.F., aerial and oscillator adjustments used in the following alignment instructions can be gained simply by removing the cabinet back cover.

**I.F. Stages.**—Screw out the core adjustments of **L5**, **L6**, **L7** and **L8** to their fullest extent. Connect signal generator, via an isolating

clear of powerful signals. Feed in a 465 kc/s (645.16 m) signal and adjust the cores of **L8** (location reference C2) and **L7** (C2) for maximum output. Transfer "live" signal generator lead to control grid (pin 6) of **V1**, feed in a 465 kc/s signal and adjust **L6** (B2) and **L5** (B2) for maximum output. Repeat these adjustments, starting again at **L7** and **L8** with the signal generator connected to **V2** control grid.

**R.F. and Oscillator Stages.**—If the receiver is to be aligned out of its cabinet, use may be made of the calibration points on the metal scale reflector plate. These points take the form of a line of indentations on the top rear edge of the plate. Viewed from the rear of the chassis and reading from left to right, these indentations represent the following calibration points: Maximum capacitance setting of gang; 500 m; 1,400 m; 300 m; 1,200 m; 200 m. Check that with the gang at maximum capacitance, the cursor coincides with the maximum capacitance calibration point on the reflector plate or with the vertical lines at the high wavelength end of the tuning scale.

The signal generator should be coupled to the receiver via a single loop of wire about the same size as the frame aerial, and placed 12 to 18 inches away from it. The M.W. alignment should be carried out first as **C28** and **C24** are common to both wavebands and will affect L.W. adjustments.

**M.W.**—Switch receiver to M.W., tune to 500 m, feed in a 500 m (600 kc/s) signal and adjust the core of **L3**, **L4** (H4) for maximum output. Tune receiver to 200 m, feed in a 200 m (1,500 kc/s) signal and adjust **C28** (G4) and **C24** (G4) for maximum output. Repeat these adjustments.

**L.W.**—Switch receiver to L.W., tune to 1,402 m, feed in a 1,402 m (214 kc/s) signal and adjust **C27** (G4) and **C23** (G4) for maximum output.

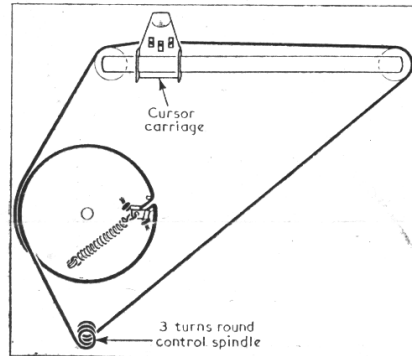

Sketch of the drive cord system drawn as seen from rear of chassis with gang at maximum.

capacitor in each lead, to control grid (pin 6) of **V2** and chassis. Switch receiver to M.W. and tune to a point around 300 m which is

**VALVE ANALYSIS**

Valve voltages and currents given in the table below are those derived from the manufacturer's information. They were measured on a receiver operating from 230 V A.C. mains, and switched to M.W. There was no signal input.

Voltages were measured on the 1,000 V and 10 V ranges of a Model 7 Avometer, chassis being the negative connection. Total cathode current of the rectifier **V5** was quoted at 39 mA.

Valve	Anode		Screen		Cath.
	V	mA	V	mA	V
V1 UCH42	98	1-5	47	1-6	0-8
	Oscillator				
	47	0-5			
V2 UF41	98	2-5	47	0-8	1-0
V3 UBC41	74	0-2	—	—	1-0
V4 UL41	190	27-5	98	4-0	5-0
V5 UY41	222*	—	—	—	205-0

\* A.C. reading.

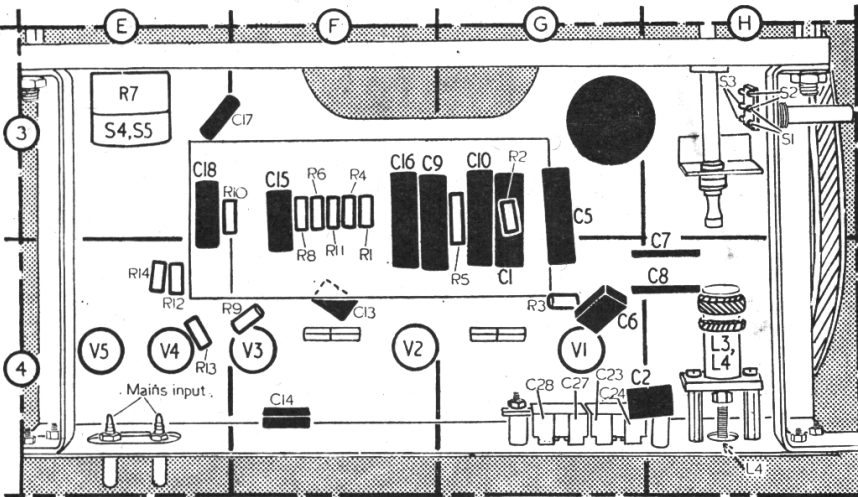

Under-side view of chassis, showing the waveband switch unit in detail (location H3).