

"TRADER" SERVICE SHEET

1097

FERGUSON 353 Series

Covering Early and Late Versions
of 353A and 353U Receivers

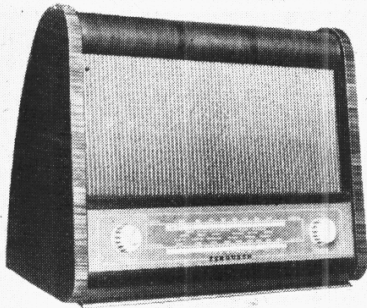

BOTH the A.C. and A.C./D.C. versions of the Ferguson 353 series are covered here, together with a full description of the differences between them and two earlier versions of the same series.

The basic A.C. receiver, model 353A, is a 3-valve (plus rectifier) 3-band superhet table model, with a frame aerial for M.W. and L.W., designed to operate from A.C. mains of 200-250V, 40-60 c/s using a

double-wound transformer. The A.C./D.C. version, model 353U, is designed to operate from mains of the same range ratings. Differences between our samples and the early versions are fully explained under "Modifications" overleaf.

Release date and original price, all models: November, 1952, £16 3s 1d.

CIRCUIT DESCRIPTION

Tuned frame aerial input by **L1**, **C33** (M.W.) and **L1**, loading coil **L3** and **C33** (L.W.). On S.W. the tuned circuit **L4**, **C33** is coupled via **L2** to the frame aerial, which then acts as an untuned internal aerial, provision also being made for the connection of an external aerial via **C1**. **R1** is shunted across **L3** to give an increased margin of stability on L.W. In the A.C./D.C. model **C39** isolates the **E** socket from chassis which is "live" to the mains.

V1 (Mullard **ECH42** (A.C. model) or **UCH42** (A.C./D.C. model)) is a triode hexode valve operating as frequency changer with internal coupling. Oscillator grid coils **L5** (S.W.), **L6** (M.W.) and **L7** (L.W.) are tuned by **C34**. Parallel trimming by **C35** (S.W.), **C36** (M.W.) and **C8**, **C37** (L.W.); series tracking by **C10**

(S.W.), **C12** (M.W.) and **C9**, **C12**, **C38** (L.W.). Reaction coupling across the common impedance of tracker **C12** (M.W. and L.W.) and via **L8** (S.W.). **R5** limits the reaction coupling on M.W. and L.W. Oscillator stabilization by **R7**.

Second valve (**V2** Mullard **EBF80** (A.C. model) or **UBF80** (A.C./D.C. model)) is a double diode pentode valve, its pentode section operating as a reflex I.F./A.F. amplifier with tuned transformer I.F. couplings **C5**, **L9**, **L10**, **C6** and **C18**, **L12**, **C19**.

Intermediate frequency 470 kc/s.

First diode section of **V2** operates as signal detector, the A.F. component in its rectified output being developed across volume control **R13**, which acts as diode load, and passed via **C14** and **L10** to control grid of **V2** pentode section, which then operates as A.F. amplifier. I.F. filtering by **C13**, **R15**, **C20** and **C21**. Provision is made for the connection of a gramophone pick-up across **R13**, the pick-up sockets in the A.C./D.C. model being isolated from chassis by **C40** and **C41**.

Second diode of **V2** is fed via **C17** from **V2** pentode anode, and the resulting D.C. component is developed across load

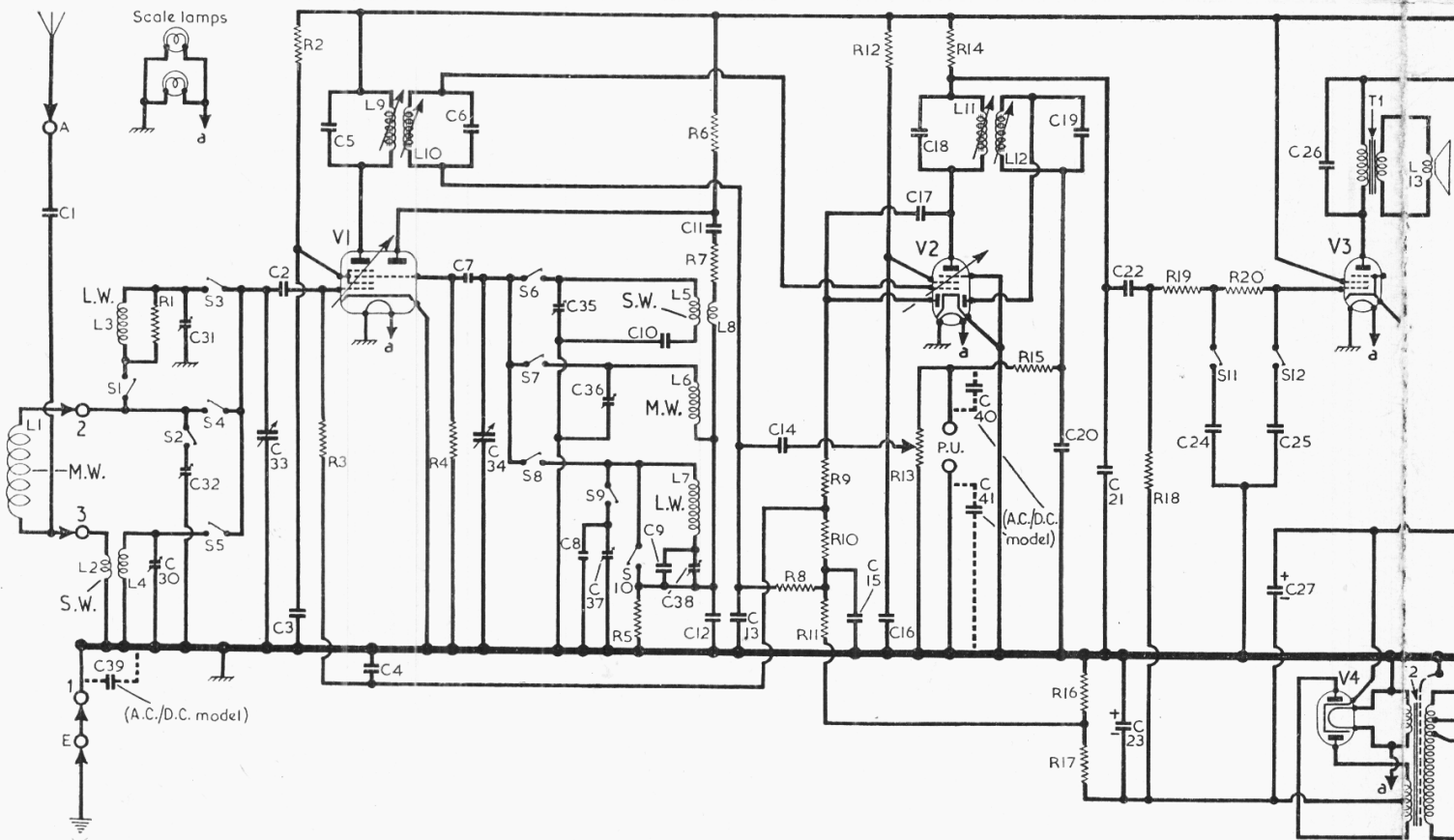

resistors **R9, R10, R11**, which act as a potential divider, bias for **V1** and **V2** being tapped off from it to give automatic gain control.

Amplified A.F. output from **V2** is developed across audio load resistor **R14** and passed via **C22, R19** and **R20** to pentode output valve (**V3, Mullard EL41** (A.C. model) or **UL41** (A.C./D.C. model)). Tone correction in anode circuit by **C26**. Three-position tone control is provided by **C24, C25** and switches **S11, S12**.

In the A.C. model H.T. current is supplied by full-wave I.H.C. rectifying valve (**V4, Mullard EZ40**). Smoothing by **R21, R22** and electrolytic capacitors **C27, C28** and **C29**. A double-wound mains transformer **T2** feeds the valve heaters from a common secondary winding. Grid bias for **V3** is developed across **R16, R17** in the H.T. negative lead to chassis. A proportion of this voltage, that across **R16**, is used as delay bias for the A.G.C. diode and standing bias for **V1** and **V2** pentode section.

In the A.C./D.C. model H.T. current is supplied by half-wave I.H.C. rectifying valve (**V4, Mullard UY41**). Smoothing by **R21, R25** and electrolytic capacitors **C27, C42** and **C43**. The valve heaters, together with ballast resistor **R27**, scale lamps with shunts **R28** and **R29**, and mains R.F. filter chokes **L14, L15**, are connected in series across the mains input. **R26** protects **V4**, and **R28** the scale lamps, from current surges. Thermistor **R29** (**Brimistor, CZ2**) maintains the heater circuit should the scale lamps fail, and prevents **R28** from being overloaded by the heater current.

COMPONENTS AND VALUES

| CAPACITORS | | Values | Locations |
|------------|------------------------|---------------|-----------|
| C1 | Aerial coupling ... | 0.001 μ F | — |
| C2 | V1 C.G. ... | 200pF | G3 |
| C3 | V1 S.G. decoupling ... | 0.05 μ F | G3 |
| C4 | A.G.C. decoupling ... | 0.02 μ F | G3 |
| C5 | 1st I.F. trans. ... | 100pF | B1 |
| C6 | tuning ... | 100pF | B1 |
| C7 | V1 osc. C.G. ... | 50pF | G3 |
| C8 | L.W. osc. trim. ... | 50pF | G3 |
| C9 | L.W. osc. tracker ... | 250pF | G3 |
| C10 | S.W. osc. tracker ... | 4,550pF | F3 |
| C11 | Osc. anode coup. ... | 100pF | F3 |
| C12 | M.W. osc. tracker ... | 520pF | F3 |
| C13 | A.G.C. decoupling ... | 500pF | E3 |
| C14 | A.F. coupling ... | 0.01 μ F | D3 |
| C15 | A.G.C. decoupling ... | 0.05 μ F | E4 |
| C16 | V2 S.G. decoupling ... | 0.1 μ F | E4 |
| C17 | A.G.C. coupling ... | 100pF | E3 |
| C18 | 2nd I.F. trans. ... | 100pF | C1 |
| C19 | tuning ... | 100pF | C1 |
| C20 | I.F. by-passes ... | 200pF | D3 |
| C21 | A.F. coupling ... | 0.002 μ F | D3 |
| C22 | A.F. coupling ... | 0.01 μ F | E4 |
| C23* | G.B. by-pass ... | 100 μ F | E4 |
| C24 | Parts tone control ... | 0.002 μ F | D3 |
| C25 | Parts tone control ... | 0.002 μ F | D3 |
| C26 | Tone corrector ... | 0.002 μ F | B2 |
| C27* | H.T. Smoothing ... | 32 μ F | G4 |
| C28* | H.T. Smoothing ... | 24 μ F | G4 |
| C29* | H.T. Smoothing ... | 24 μ F | G4 |
| C30† | S.W. aerial trim. ... | 70pF | A1 |
| C31† | L.W. aerial trim. ... | 70pF | A1 |
| C32† | M.W. aerial trim. ... | 30pF | A2 |
| C33† | Aerial tuning ... | 528pF | A1 |
| C34† | Oscillator tuning ... | 528pF | A1 |
| C35† | S.W. osc. trim. ... | 70pF | A1 |
| C36† | M.W. osc. trim. ... | 70pF | A1 |
| C37† | L.W. osc. trim. ... | 70pF | A1 |
| C38† | L.W. osc. tracker ... | 70pF | A2 |
| C39 | Earth isolator ... | 0.005 μ F | — |
| C40 | P.U. isolators ... | 0.005 μ F | — |
| C41 | P.U. isolators ... | 0.05 μ F | — |
| C42* | H.T. smoothing ... | 32 μ F | — |
| C43* | H.T. smoothing ... | 16 μ F | — |
| C44 | Mains R.F. by-pass | 0.01 μ F | — |

| RESISTORS | | Values | Locations |
|-----------|---------------------------|-----------------|-----------|
| R1 | L.W. stabilizer ... | 220k Ω | G3 |
| R2 | V1 S.G. feed ... | *47k Ω | E3 |
| R3 | V1 C.G. ... | 1M Ω | G3 |
| R4 | V1 osc. C.G. ... | 47k Ω | F3 |
| R5 | Osc. reaction limiter ... | 3.9k Ω | F3 |
| R6 | Osc. anode feed ... | *27k Ω | F4 |
| R7 | Osc. stabilizer ... | 220 Ω | F3 |
| R8 | V2 C.G. ... | 1M Ω | E3 |
| R9 | A.G.C. potential ... | †270k Ω | E3 |
| R10 | A.G.C. potential ... | †1.2M Ω | E3 |
| R11 | divider ... | **47k Ω | E4 |
| R12 | V2 S.G. feed ... | 100k Ω | E3 |
| R13 | Volume control ... | 500k Ω | D3 |
| R14 | V2 A.F. load ... | 10k Ω | E3 |
| R15 | I.F. stopper ... | 100k Ω | E3 |
| R16 | G.B. potential ... | 39 Ω | E4 |
| R17 | divider ... | 82 Ω | E4 |
| R18 | V3 C.G. ... | 470k Ω | E4 |
| R19 | Parts tone control ... | 47k Ω | E3 |
| R20 | Parts tone control ... | 47k Ω | E4 |
| R21 | H.T. smoothing ... | 470 Ω | G4 |
| R22 | H.T. smoothing ... | 820 Ω | G4 |
| R23 | G.B. potential ... | 33 Ω | — |
| R24 | divider ... | 150 Ω | — |
| R25 | H.T. smoothing ... | 820 Ω | — |
| R26 | V4 surge limiter ... | 140 Ω | — |
| R27 | Heater ballast ... | †1,220 Ω | — |
| R28 | Scale lamp shunt ... | 1.2k Ω | — |
| R29 | Brimistor CZ2 ... | — | — |

* 33k Ω } A.C./D.C.
 † 330k Ω } model
 ** 150k Ω }
 † Tapped at 820 Ω + 200 Ω + 200 Ω from L14.
 † 22k Ω } A.C./D.C.
 § 680 k Ω } model
 || 27k Ω }

| OTHER COMPONENTS | | Approx. Value (ohms) | Locations |
|------------------|----------------------------|----------------------|-----------|
| L1 | Frame aerial ... | 1.5 | — |
| L2 | S.W. aerial coup. ... | — | G3 |
| L3 | L.W. loading coil ... | 15.0 | G3 |
| L4 | S.W. aerial tuning ... | — | G3 |
| L5 | Oscillator tuning ... | — | F3 |
| L6 | coils ... | 2.7 | G4 |
| L7 | coils ... | 12.0 | G4 |
| L8 | S.W. osc. reaction ... | — | F3 |
| L9 | 1st I.F. trans. { Pri. ... | 8.0 | B1 |
| L10 | { Sec. ... | 8.0 | B1 |
| L11 | 2nd I.F. trans. { Pri. ... | 8.0 | C1 |
| L12 | { Sec. ... | 6.0 | C1 |
| L13 | Speech coil ... | 2.5 | — |
| L14 | R.F. filter chokes ... | 3.5 | — |
| L15 | R.F. filter chokes ... | 3.5 | — |
| T1 | O.P. trans. { Pri. ... | 480.0 | B1 |
| | { Sec. ... | — | — |
| T2 | Mains { Pri., total ... | 41.0 | C2 |
| | { H.T. sec., total ... | 550.0 | — |
| S1-S10 | Waveband switches ... | — | G3 |
| S11, S12 | Tone control sw. ... | — | D3 |
| S13, S14 | Mains sw., g'd R13 ... | — | D3 |

GENERAL NOTES

Switches.—S1-S10 are the waveband switches, ganged in a single 3-position rotary unit beneath the chassis. The unit is indicated in our underside view of the chassis, and is shown in detail in the diagram in col. 1 overleaf, where it is drawn as seen when viewed from the rear of an inverted chassis.

The table beside it gives the switch positions for the three control settings, starting from the fully anti-clockwise position of the control spindle. A dash indicates open, and C, closed.

S11, S12 are the tone control switches, in a 3-position unit beneath the chassis. This is indicated in our underside view of the chassis, and shown again in the diagram in col. 3 overleaf, where it is viewed in the same direction as seen in the chassis drawing.

Scale Lamps.—These are two M.E.S. type lamps, with small clear spherical bulbs. In the A.C. version they are rated at 6.3 V, 0.3 A, and the A.C./D.C. version they are rated at 8 V, 0.15 A. They are in plastic holders which can be withdrawn from their flat mounting lugs without removing the chassis.

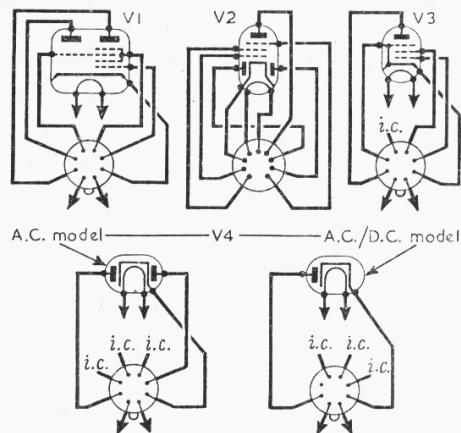

* Electrolytic.
 † Variable.
 ‡ Pre-set.
 § "Swing" value, minimum to maximum.
 ¶ Two capacitors, 1,000pF and 3,550pF, in parallel.
 || 0.005 μ F in A.C./D.C. model.

Circuit diagram of the Ferguson Model 353A. The A.C./D.C. version, Model 353U, is covered by the additional power supply circuit inset below, the only other differences between these two models in the main diagram being the addition of isolating capacitors drawn in broken line.

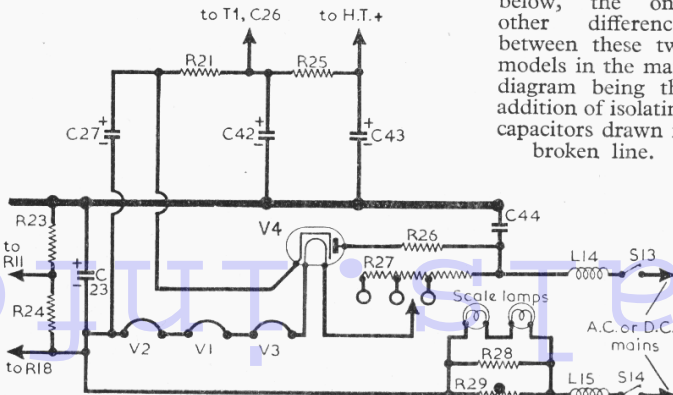
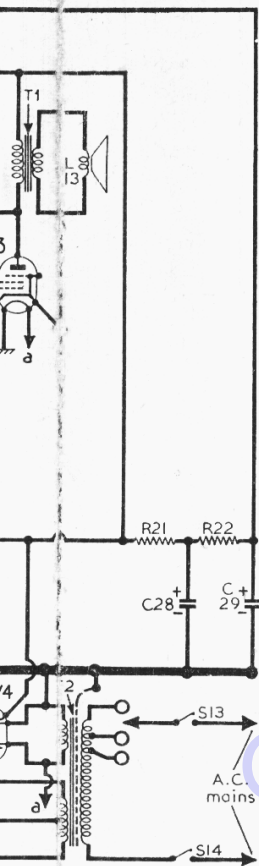

Waveband Switch Diagram and Table

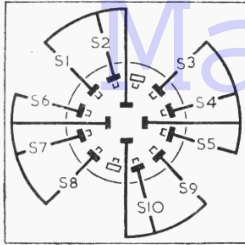

Waveband switches, drawn as seen from the rear of an inverted chassis. On the right is the associated table.

| Switches | S.W. | M.W. | L.W. |
|----------|------|------|------|
| S1 | — | — | C |
| S2 | — | — | C |
| S3 | — | C | — |
| S4 | — | C | — |
| S5 | — | C | — |
| S6 | — | C | — |
| S7 | — | C | — |
| S8 | — | — | C |
| S9 | — | — | C |
| S10 | — | C | — |

Tone control switches, drawn as indicated in the under-chassis view.

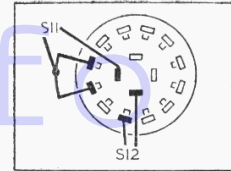

VALVE ANALYSIS

Valve voltages and currents given in the tables below are those derived from the manufacturers' information and were measured with the receivers operating from 230 V A.C. mains, the voltage adjustments being set to the 220-230 V tappings. The receivers were tuned to a point at the high wavelength end of the M.W. scale where there was no signal pick-up. Measurements made on early production models were slightly higher than those quoted in our tables.

Voltages were measured on the 10 V and 400 V ranges of a Model 7 Avometer, chassis being the negative connection in every case. In the A.C. model, the voltage across C27 was 243 V, across C28 it was 234 V and across R16, R17 it was 5.7 V. In the A.C./D.C. model the voltage across C27 was 190 V, across C42 was 166 V and across R23, R24 it was 9.5 V.

A.C. Model

| Valve | Anode | | Screen | |
|----------|-------------------|----------|--------|-----|
| | V | mA | V | mA |
| V1 ECH42 | 220 Oscillator | 2.4 4 | 70 | 2.9 |
| V2 EBF80 | 72 | 5.5 | — | — |
| V3 EL41 | 175 | 4.2 | 60 | 1.6 |
| V4 EZ40 | 228 | 26.5 | 220 | 3.8 |
| | 240* | — | — | — |

* A.C. reading, each anode.

A.C./D.C. Model

| Valve | Anode | | Screen | |
|----------|-------------------|------------|--------|-----|
| | V | mA | V | mA |
| V1 UCH42 | 150 Oscillator | 2.6 3.1 | 60 | 2.8 |
| V2 UBF80 | 70 | 3.1 | — | — |
| V3 UL41 | 83 | 6.0 | 85 | 2.5 |
| V4 UY41 | 155 | 29.0 | 150 | 6.0 |
| | 222* | — | — | — |

* A.C. reading.

MODIFICATIONS

There are two versions of the 353 series, an early production version and a late production version. This Service Sheet was prepared from two samples of the late version, and our information is presented as it was in those samples, one A.C., and the other A.C./D.C.

Our circuit diagram is based on the A.C. version, but differences in the A.C./D.C. version are shown in the diagram by additional items connected by broken lines, and outside it by a separate section diagram of the A.C./D.C. power supply circuit. Where component values

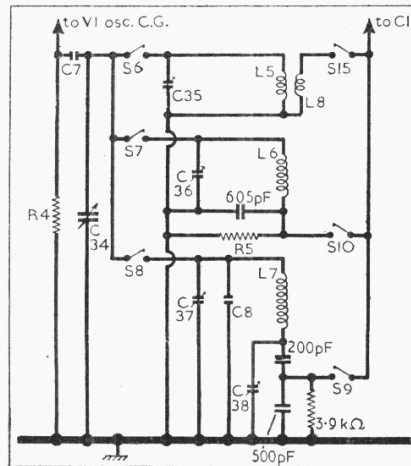

Oscillator circuit of the early version receiver, showing the differences between this and the late version described under "Modifications."

differ between the A.C. and A.C./D.C. models, these are indicated in the component tables. One difference that may be found in all versions is the omission of R1.

Early Version.—Differences between our sample and the earlier production version are numerous, and the oscillator circuit is quite different. A diagram of the earlier oscillator circuit is shown above, where the component

values that are different from ours are shown. C10 was omitted, and so was R7, and R6 was 22 kΩ. The control grid and anode sections were physically transposed on the waveband switch wafer as compared with our switch diagram.

There were a few differences in the aerial circuit. C1, which is now 0.001 μF, was 15 pF, and it went to the top of L1 instead of the bottom, so that the external aerial could be used on M.W. and L.W. R1 was omitted, and C32 was permanently connected to the top of L1. C31 was then a fixed 47 pF capacitor, and its position in our plan view was then occupied by C32, which in our sample was a single unit, not part of an assembly. C32 was 70 pF. L2, L3, L4 were mounted on the chassis deck.

In the A.F. circuits, C40 was included in both A.C. and A.C./D.C. versions, and C26 was 0.005 μF. The tone control circuit was omitted from V3 control grid circuit and was connected across C26, but the switch then became a single-pole 3-position unit, and it shunted a 0.01 μF or a 0.005 μF, or neither, across T1 primary. R19 and R20 were then a single 100 kΩ grid stopper.

Chassis of the early production can be recognized by the presence of the aerial coils L2, L3, L4 in the chassis deck, a 2-pin frame aerial plug and an E socket lead soldered to a chassis tag. The late production chassis can be recognized by the absence of tuning coils on the chassis deck, the presence of the lone trimmer C32 mounted vertically on the deck, and the use of a 3-pin frame aerial plug.

CIRCUIT ALIGNMENT

I.F. Stages.—Remove chassis from cabinet and stand it on the bench with the frame aerial connected. Switch set to M.W. and turn gang and volume control to maximum. Connect output of signal generator, via an 0.1 μF capacitor in each lead, to the junction of C33 and C2, and to chassis. Feed in a 470 kc/s (638.3 m) signal and adjust the cores of L12 (location reference C1), L11 (E3), L10 (B1) and L9 (F3) for maximum output, reducing the input as the circuits come into line to avoid A.G.C. action. Repeat these adjustments until no further improvement results.

Late Production Models

R.F. and Oscillator Stages.—Replace chassis in cabinet, leaving the back open to give access to the trimmers but keeping the frame aerial connected. Disconnect signal generator leads and lay them near the frame aerial. The alignment points given in the following instructions are indicated by calibration marks above the clear sections of the tuning scale. Check that with the gang at maximum capacitance the cursor coincides with the vertical marks at the high wavelength ends of the tuning scales.

S.W.—Switch receiver to S.W., tune to 17 Mc/s, feed in a 17 Mc/s (17.65 m) signal and adjust C35 (A1) and C30 (A1) for maximum output, "rocking" the gang while adjusting

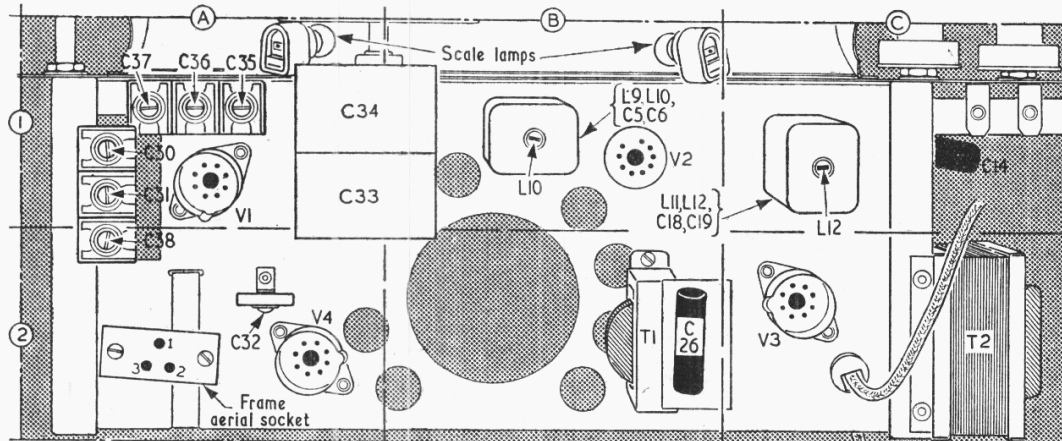

Plan view of chassis, showing the vertically mounted trimmer C32 which in the early version models takes the place where we show C31, this trimmer being replaced by a fixed capacitor. The frame aerial socket is a 2-pin type in the early versions.

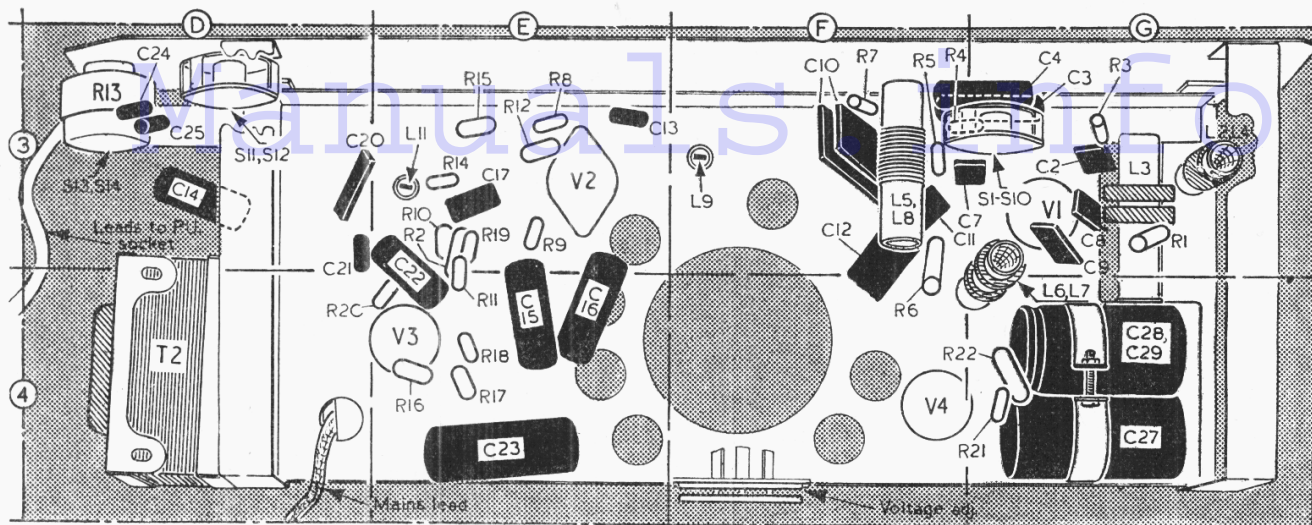

Under-chassis view of receiver. The arrows pointing to the tone control and waveband switches indicate the directions in which they are viewed in the diagrams in cols. 1 and 3.

the latter for optimum results. Repeat these adjustments until no further improvement results.

M.W. Oscillator.—Switch receiver to M.W., tune to 200 m, feed in a 200 m (1,500 kc/s) signal and adjust **C36** (A1) for maximum output.

L.W.—Switch receiver to L.W., tune to 857 m, feed in an 857 m (350 kc/s) signal and adjust **C37** (A1) and **C31** (A1) for maximum output. Tune receiver to 1,875 m, feed in a 1,875 m (160 kc/s) signal and adjust **C38** (A2) for optimum results. Repeat these adjustments until no further improvement results.

M.W. Aerial.—Replace cabinet back cover and lay the signal generator leads near the frame aerial. Switch receiver to M.W., tune to 200 m, feed in a 200 m (1,500 kc/s) signal and adjust **C32** (A2), through the hole provided in the back cover, for maximum output.

Early Production Models

R.F. and Oscillator Stages.—As calibration marks are not printed on the tuning scale in these models, it will be found difficult to set the cursor accurately for the L.W. trimming and tracking points (on S.W. and M.W. these points coincide with scale divisions), and to facilitate this operation, a substitute tuning scale should be made up in the following way. Measure off on a strip of paper two calibration marks, the first at 1 7/8 in, and the second at

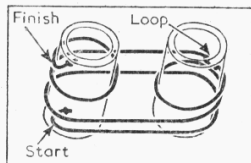

Sketch of volume control drive cord system, as seen from front of chassis.

7/8 in from the right-hand edge of the paper. These points represent the cursor settings for L.W. tracking and trimming respectively, and the paper should be held up to the tuning scale with its right-hand edge lined up with the high wavelength ends of the tuning scales.

After completing the I.F. stage alignment, replace chassis in cabinet. Disconnect signal generator leads and lay them near the frame aerial. Check that with the gang at maximum capacitance the cursor coincides with the high wavelength ends of the tuning scales.

S.W. and M.W.—Alignment on these bands should be carried out as described for the late production models, but when adjusting the aerial circuit on M.W., the cabinet back must be unfastened at the top to give access to trimmer **C32** which is part of the trimmer bank in location A1, and takes the place of **C31**.

L.W.—Switch receiver to L.W., tune to tracking point on substitute scale, feed in a 1,875 m

(160 kc/s) signal and adjust **C38** (A2) for maximum output. Tune receiver to trimming point on substitute scale, feed in an 857 m (350 kc/s) signal and adjust **C37** (A1) for maximum output, while rocking the gang for optimum results.

DRIVE CORD REPLACEMENT

Tuning Drive.—This is unusual, in that there is a two-to-one step-up drive on the cursor section of the cord, devised by means of an anchored loop to which the cursor is attached. Altogether, about five feet of high-grade flax fishing line, plaited and waxed, is required, and it is divided into three lengths.

First make the cursor loop. This consists of a cord with a small loop at each end, measuring 13 3/4 in overall. The two loops are slipped over the anchor stud and preferably pulled up tight so that they won't slip off. The large loop so formed is identified as the cursor loop in the accompanying sketch, which shows the complete system as seen from the front with the gang at maximum.

Next make up the cord **L**. For this take about 20 in of cord and tie the left-hand eyelet **L** to one end of it, but doing so while the anchored loop lies in the eyelet groove, so that not only the eyelet but the loop also is included. At the remote end of cord **L** make a small loop for anchoring, so that the overall length of cord **L** is 18 3/4 in. Then hook the end loop to the tension spring and run the cord as shown in the sketch.

Now take about 26 in of cord for cord **R**, and tie one end to eyelet **R**, again including the cursor loop. Make a small loop at the far end big enough to take a 4BA screw, so that the overall length is 23 3/4 in. The cord system is now completely made up, and cord **R** is run as shown in the sketch, pulling against the gang stop all the way, until the end loop is anchored to the boss screw in the gang drum, as shown. The tension can be eased while fixing this end by slipping the spring off its anchor temporarily.

The cursor should be fitted afterwards, and is adjusted as described under "Circuit Alignment."

Volume Control Drive.—The volume control is offset from its control knob by about an inch and a half, and the drive is transferred to it by cord of the same type as is used for the tuning drive. Two feet of cord is ample.

The cord is run as shown in the accompanying sketch (col. 4) where it is drawn as seen from the front with the mains switch in the "off" position, starting and finishing as indicated by tying knots in the cord, but the full procedure is complicated by the necessity of moving the volume control to obtain tension.

First slacken the volume control fixing nut under the left-hand drum, using a thin spanner of 3/16 in between flats, and slide the volume control along towards the right-hand drum as far as it will go, and tighten up nut lightly.

Run the cord as shown, anchoring it to the drums by means of the slots, and make it as tight as possible. Then slacken the fixing nut again and pull the volume control as far as possible away from the right-hand drum, working the control backwards and forwards to allow the slack to be taken up, and tighten up the nut again with the cord in firm tension. A touch of Duroflex on the knots will prevent them from slipping.

DISMANTLING

Removing Chassis.—Remove back cover and unplug frame aerial lead (on Early Versions unsolder chassis lead from **E** socket); unsolder leads from speech coil tags on speaker; remove two wood screws securing P.U. socket panel to side of cabinet; remove four self-tapping screws and large washers securing chassis to cabinet (in the A.C./D.C. model the screw heads are covered by cardboard insulating caps which must first be prised off); withdraw chassis complete with knobs.

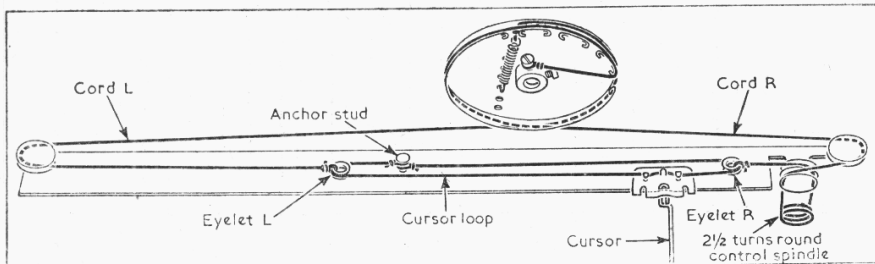

Sketch of tuning drive system, drawn as seen from front of chassis with the gang at maximum capacitance. There are three cords in the system, one of which, the cursor loop, is tied to an anchor stud to effect a two-to-one step-up in cursor movement.