

"TRADER" SERVICE SHEET  
1094

# VIDOR CN414

All-dry Battery Portable

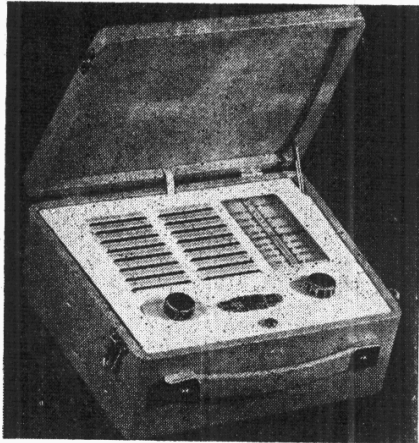

**T**HE Vidor CN414 is a 4-valve, 2-band superhet portable, which operates from self-contained dry batteries. Its waveband coverage is 180-550 m and 1,150-1,900 m. No normal on/off battery switch is fitted, an automatic switch controlling this function upon opening or closing the lid.

Release date and original price: May 1951, £10 17s 1d, without batteries. Purchase tax extra.

### CIRCUIT DESCRIPTION

Tuned frame aerial input **L1**, **C19**, shunted by **C1**, **C18** (L.W.) precedes heptode valve (**V1**, Mullard **DK91**) which operates as frequency changer with electron

coupling. For M.W. operation, **S1** closes and shunts **L2** across **L1**.

A single oscillator grid coil **L3** (M.W.) is tuned by **C20**. For L.W. operation **C7** is shunted across **L3**. Parallel trimming by **C21** (M.W.) and **C21**, **C7** (L.W.); series tracking by **C6** (M.W. and L.W.). Inductive reaction coupling from oscillator anode by **L4** on M.W. and L.W.

Second valve (**V2**, Mullard **DF91**) is a variable-mu R.F. pentode operating as intermediate frequency amplifier with tuned transformer couplings **C3**, **L5**, **L6**, **C4** and **C10**, **L7**, **L8**, **C11**.

Intermediate frequency 475 kc/s.

Diode signal detector is part of diode pentode valve (**V3**, Mullard **DAF91**). Audio frequency component in rectified output is developed across volume control **R6**, which acts as diode load, and is passed via **C13** to control grid of pentode section, operating as A.F. amplifier. I.F. filtering by **C12**, **R5**, the capacitance of the screened leads and **C15**.

D.C. potential developed across **R5**, **R6** is fed back as bias via decoupling circuit **R4**, **C8** to **V1** and **V2**, giving automatic gain control.

Resistance-capacitance coupling by **R9**, **C16** and **R11** between **V3** pentode and pentode output valve (**V4**, Mullard **DL94**). Grid bias for **V4** is obtained from the voltage drop across **R10** in the H.T. negative lead to chassis. **C17** shunts the H.T. circuit to prevent instability if the internal resistance of the H.T. battery increases. Battery switches **S4** and **S5** are operated by opening or closing the carrying case lid. The two halves of **V4** filament are connected in parallel to operate from the 1.5 V L.T. supply.

### COMPONENTS AND VALUES

CAPACITORS		Values	Locations
C1	L.W. aerial trim. ...	150pF	G2
C2	V1 C.G. ...	100pF	G3
C3	1st I.F. trans. ...	65pF	B1
C4	tuning ...	65pF	B1
C5	V1 osc. C.G. ...	100pF	G2
C6	Osc. tracker ...	635pF	F2
C7	L.W. osc. trim. ...	515pF	F2
C8	A.G.C. decoupling ...	0.05µF	F3
C9	H.T. decoupling ...	0.1µF	B1
C10	2nd I.F. trans. tun. ...	65pF	C1
C11	I.F. by-pass ...	65pF	C1
C12	I.F. by-pass ...	100pF	E3
C13	A.F. coupling ...	0.001µF	E2
C14	V3 S.G. decoupling ...	0.05µF	D3
C15	I.F. by-pass ...	200pF	D3
C16	A.F. coupling ...	0.01µF	D3
C17*	H.T. reservoir ...	2µF	B1
C18†	L.W. aerial trim. ...	70pF	A1
C19†	Aerial tuning ...	5523pF	A1
C20†	Oscillator tuning ...	5523pF	A1
C21‡	M.W. osc. trim. ...	70pF	A1

\* Electrolytic.

† Variable.

‡ Pre-set.

§ Swing valve, minimum to maximum.

### RESISTORS

RESISTORS	Values	Locations	
R1	V1 C.G. ...	470kΩ	F3
R2	V1 osc. C.G. ...	100kΩ	F3
R3	H.T. decoupling ...	12kΩ	E2
R4	A.G.C. decoupling ...	2.2MΩ	E3
R5	I.F. stopper ...	100kΩ	E3
R6	Volume control ...	1MΩ	—
R7	V3 C.G. ...	4.7MΩ	D2
R8	V3 S.G. feed ...	4.7MΩ	D2
R9	V3 anode load ...	1MΩ	D2
R10	V4 G.B. ...	820Ω	E3
R11	V4 C.G. ...	2.2MΩ	D3

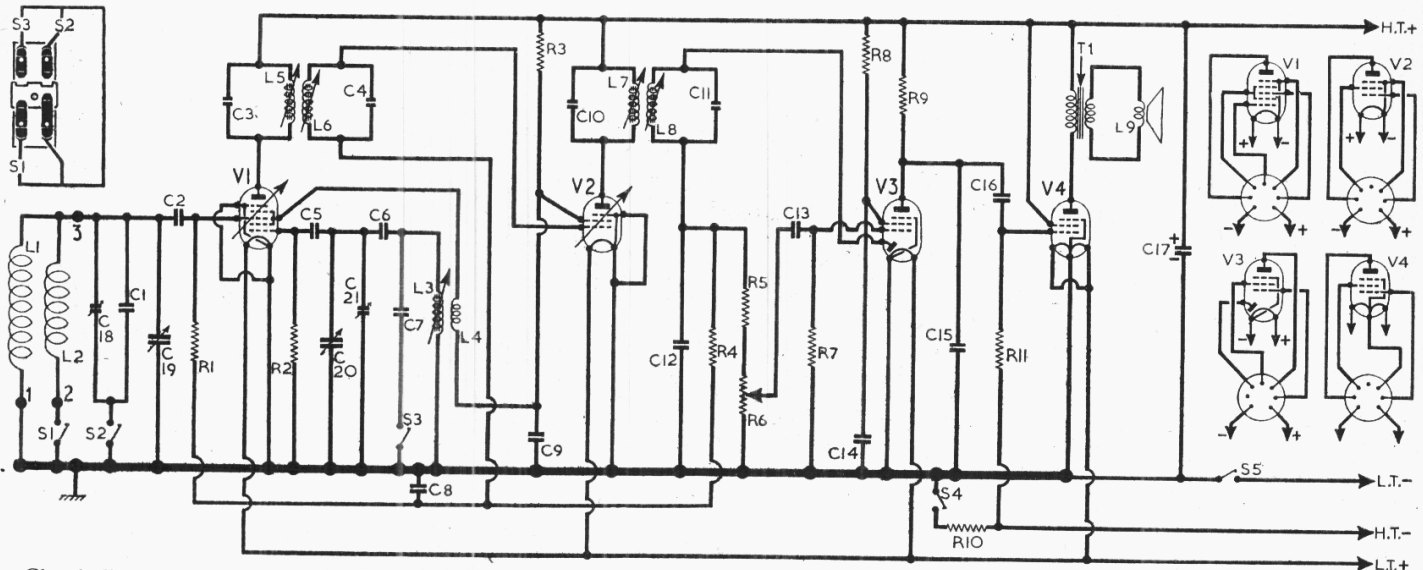

Circuit diagram of the Vidor CN414 all-dry battery portable superhet. Inset in the top left-hand corner is a diagram of the waveband switch. ]



OTHER COMPONENTS		Approx. Values (ohms)	Locations
L1	L.W. frame aerial	1-5	—
L2	M.W. frame aerial	13-0	—
L3	Osc. tuning coil	1-8	F2
L4	Osc. reaction coil	1-0	F2
L5	1st I.F. trans.	{Pri. 20-0	B1
L6		{Sec. 20-0	B1
L7	2nd I.F. trans.	{Pri. 20-0	C1
L8		{Sec. 20-0	C1
L9	Speech coil	2-6	—
T1	O.P. trans.	{Pri. 540-0	—
		{Sec. —	—
S1-S3	Waveband switches	—	G2
S4, S5	Battery switches	—	—

**VALVE ANALYSIS**

Valve voltages and currents given in the table below are those measured in our receiver when it was operating from a new set of batteries. The receiver was switched to M.W. and tuned to around 500 m, a point being selected where there was no signal pick-up.

Voltages were measured with an Avo Electronic TestMeter, and as this instrument has a high internal resistance, allowance should be made for the current drawn by other types of meter. Chassis was the negative connection in every case. The voltage measured across R10 was 8 V.

Valve	Anode		Screen	
	V	mA	V	mA
V1 DK91 ...	82	1-7	47	2-5
V2 DF91 ...	82	1-6	47	0-45
V3 DAF91 ...	18	0-07	19	0-016
V4 DL94 ...	80	3-0	82	0-55

**DISMANTLING THE SET**

Practically all the components can be made accessible by raising the metal escutcheon (milled-edge thumb-screw at front edge of escutcheon).

**Removing Chassis.**—Unsolder leads from tags on volume control;

unsolder red and black leads from tags on speaker transformer T1;

unsolder frame aerial leads from their junctions on the chassis (numbered 1-3 in locations F3 and G2 on underchassis view);

remove three 4BA nuts securing chassis to escutcheon, and withdraw chassis.

**When replacing,** the metal spacers should be in position on the chassis fixing bolts.

The frame aerial lead nearest to the output transformer in the paxolin spacer should be connected to junction 3 (as indicated in the under-chassis view), the centre lead to junction 2 and the remaining lead to junction 1.

The volume control leads should be connected as follows: viewing the control from the rear, with the tags at the top, connect the red systoflex lead to left-hand tag; red plastic lead to centre tag; and the black lead to right-hand tag.

The volume control leads should be connected as follows: viewing the control from the rear, with the tags at the top, connect the red systoflex lead to left-hand tag; red plastic lead to centre tag; and the black lead to right-hand tag.

The volume control leads should be connected as follows: viewing the control from the rear, with the tags at the top, connect the red systoflex lead to left-hand tag; red plastic lead to centre tag; and the black lead to right-hand tag.

The volume control leads should be connected as follows: viewing the control from the rear, with the tags at the top, connect the red systoflex lead to left-hand tag; red plastic lead to centre tag; and the black lead to right-hand tag.

The volume control leads should be connected as follows: viewing the control from the rear, with the tags at the top, connect the red systoflex lead to left-hand tag; red plastic lead to centre tag; and the black lead to right-hand tag.

The volume control leads should be connected as follows: viewing the control from the rear, with the tags at the top, connect the red systoflex lead to left-hand tag; red plastic lead to centre tag; and the black lead to right-hand tag.

The volume control leads should be connected as follows: viewing the control from the rear, with the tags at the top, connect the red systoflex lead to left-hand tag; red plastic lead to centre tag; and the black lead to right-hand tag.

The volume control leads should be connected as follows: viewing the control from the rear, with the tags at the top, connect the red systoflex lead to left-hand tag; red plastic lead to centre tag; and the black lead to right-hand tag.

The volume control leads should be connected as follows: viewing the control from the rear, with the tags at the top, connect the red systoflex lead to left-hand tag; red plastic lead to centre tag; and the black lead to right-hand tag.

The volume control leads should be connected as follows: viewing the control from the rear, with the tags at the top, connect the red systoflex lead to left-hand tag; red plastic lead to centre tag; and the black lead to right-hand tag.

The volume control leads should be connected as follows: viewing the control from the rear, with the tags at the top, connect the red systoflex lead to left-hand tag; red plastic lead to centre tag; and the black lead to right-hand tag.

The volume control leads should be connected as follows: viewing the control from the rear, with the tags at the top, connect the red systoflex lead to left-hand tag; red plastic lead to centre tag; and the black lead to right-hand tag.

The volume control leads should be connected as follows: viewing the control from the rear, with the tags at the top, connect the red systoflex lead to left-hand tag; red plastic lead to centre tag; and the black lead to right-hand tag.

The volume control leads should be connected as follows: viewing the control from the rear, with the tags at the top, connect the red systoflex lead to left-hand tag; red plastic lead to centre tag; and the black lead to right-hand tag.

The volume control leads should be connected as follows: viewing the control from the rear, with the tags at the top, connect the red systoflex lead to left-hand tag; red plastic lead to centre tag; and the black lead to right-hand tag.

The volume control leads should be connected as follows: viewing the control from the rear, with the tags at the top, connect the red systoflex lead to left-hand tag; red plastic lead to centre tag; and the black lead to right-hand tag.

The volume control leads should be connected as follows: viewing the control from the rear, with the tags at the top, connect the red systoflex lead to left-hand tag; red plastic lead to centre tag; and the black lead to right-hand tag.

The volume control leads should be connected as follows: viewing the control from the rear, with the tags at the top, connect the red systoflex lead to left-hand tag; red plastic lead to centre tag; and the black lead to right-hand tag.

The volume control leads should be connected as follows: viewing the control from the rear, with the tags at the top, connect the red systoflex lead to left-hand tag; red plastic lead to centre tag; and the black lead to right-hand tag.

The volume control leads should be connected as follows: viewing the control from the rear, with the tags at the top, connect the red systoflex lead to left-hand tag; red plastic lead to centre tag; and the black lead to right-hand tag.

The volume control leads should be connected as follows: viewing the control from the rear, with the tags at the top, connect the red systoflex lead to left-hand tag; red plastic lead to centre tag; and the black lead to right-hand tag.

The volume control leads should be connected as follows: viewing the control from the rear, with the tags at the top, connect the red systoflex lead to left-hand tag; red plastic lead to centre tag; and the black lead to right-hand tag.

The volume control leads should be connected as follows: viewing the control from the rear, with the tags at the top, connect the red systoflex lead to left-hand tag; red plastic lead to centre tag; and the black lead to right-hand tag.

The volume control leads should be connected as follows: viewing the control from the rear, with the tags at the top, connect the red systoflex lead to left-hand tag; red plastic lead to centre tag; and the black lead to right-hand tag.

The volume control leads should be connected as follows: viewing the control from the rear, with the tags at the top, connect the red systoflex lead to left-hand tag; red plastic lead to centre tag; and the black lead to right-hand tag.

The volume control leads should be connected as follows: viewing the control from the rear, with the tags at the top, connect the red systoflex lead to left-hand tag; red plastic lead to centre tag; and the black lead to right-hand tag.

The volume control leads should be connected as follows: viewing the control from the rear, with the tags at the top, connect the red systoflex lead to left-hand tag; red plastic lead to centre tag; and the black lead to right-hand tag.

The volume control leads should be connected as follows: viewing the control from the rear, with the tags at the top, connect the red systoflex lead to left-hand tag; red plastic lead to centre tag; and the black lead to right-hand tag.

The volume control leads should be connected as follows: viewing the control from the rear, with the tags at the top, connect the red systoflex lead to left-hand tag; red plastic lead to centre tag; and the black lead to right-hand tag.

The volume control leads should be connected as follows: viewing the control from the rear, with the tags at the top, connect the red systoflex lead to left-hand tag; red plastic lead to centre tag; and the black lead to right-hand tag.

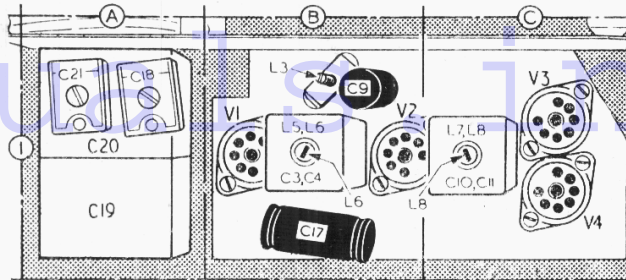

Above: Plan view of the chassis.

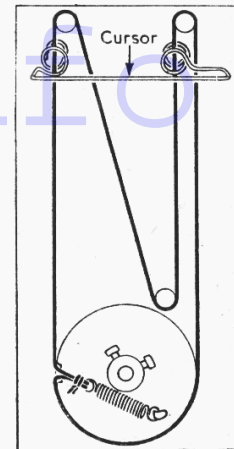

Right: Sketch showing the tuning drive system, as seen from the front with the gang at maximum.

If the battery switch has been disconnected, solder the blue and black leads to the two insulated tags, and the green lead to the tag on the mounting bracket.

**CIRCUIT ALIGNMENT**

All the following adjustments can be made accessible by hinging open the escutcheon.

**I.F. Stages.**—The I.F. coil cores are sealed with wax and should be carefully freed before alignment with a heated screw-driver blade. Switch receiver to L.W., tune to 1,800 m on scale and short-circuit the oscillator section of the gang C20. Connect signal generator output, via a 100 pF capacitor in "live" lead, to control grid (of V1) and chassis. Feed in a 475 kc/s (631.6 m) signal and adjust the cores of L8 (location reference C1), L7 (E3), L6 (B1) and L5 (E3) for maximum output, reducing the input as the circuits come into line to avoid A.G.C. action. Repeat these adjustments until no further improvement results. Re-seal cores with soft wax, taking care not to disturb their adjustment, and remove short-circuit from C20.

**R.F. and Oscillator Stages.**—Disconnect signal generator leads and lay them near the frame aerials. If insufficient signal is injected in this way, the "live" signal generator lead should be connected via a 200 pF capacitor to the junction of C2 and C19 and the other lead to the nearest chassis tag. Check that with the gang at maximum capacitance, the cursor should coincide with the 550 m mark on the M.W. section of the tuning scale.

**M.W.**—Switch receiver to M.W., tune to 200 m, feed in a 200 m (1,500 kc/s) signal and adjust C21 (A1) for maximum output. Tune receiver to 500 m, feed in

a 500 m (600 kc/s) signal and adjust the core of L3 (B1) for maximum output, rocking the gang for optimum results. Repeat these adjustments until no further improvements result.

**L.W.**—Switch receiver to L.W., tune to 1,200 m, feed in a 1,200 m (250 kc/s) signal and adjust C18 (A1) for maximum output. As there are no L.W. oscillator adjustments, the value of the tracking capacitor C6 should be checked if the L.W. calibration is not correct over the band. Its value should not be outside its rated tolerance, which is  $\pm 2\%$ . If it is necessary to replace C6, the complete R.F. and oscillator alignment should be repeated.

**GENERAL NOTES**

**Switches.**—S1-S3 are the waveband switches, ganged in a simple slide-type unit. In the M.W. position (slider towards the tuning spindle) S1 closes; on L.W., S2 and S3 close.

S4 and S5 are the battery circuit switches, mounted in a special spring-loaded unit on the side of the carrying case. It is so positioned that the lid-stay depresses the spring-loaded bar when the lid is closed, switching off the receiver. When the lid is raised, the spring brings the bar into contact with the two isolated tags, closing the switches.

**Batteries.**—The L.T. unit is a Vidor type L.5040, rated at 1.5 V. It is fitted with a 2-pin non-reversible socket, whose thicker pin is the positive. The H.T. battery is a Vidor type L.5512, rated at 90 V. It is fitted with a 3-pin non-reversible socket of which only the two outer pins are used.

**Cursor Drive Cord Replacement.**—About 30 inches of high-grade fishing line, plaited and waxed, is required for a new drive cord. It is run as shown in the sketch in col. 3, where it is drawn as seen from the front when the gang is at maximum capacitance.

To fit the cord it is necessary to remove the chassis from its mounting, although it may not be necessary to unsolder all the leads. The work is facilitated by the removal of the metal tuning scale panel, which is held by three 8BA round-head screws, with lock-washers. The cursor can be fitted afterwards.

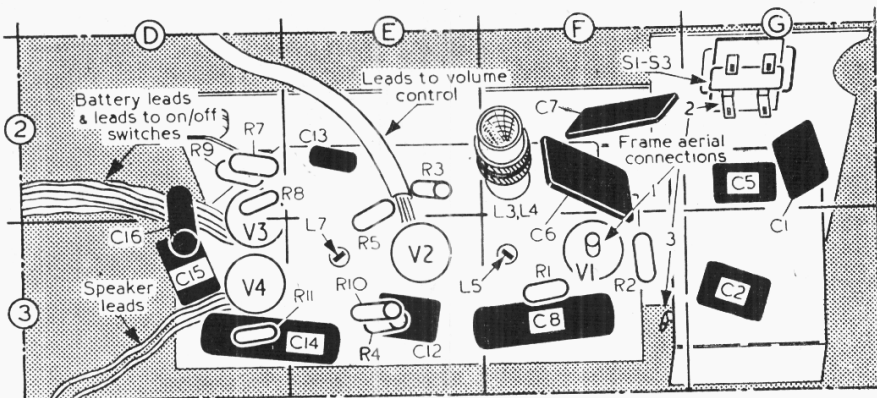

Underside view of the chassis. The leads to the volume control, speaker and aerial are indicated. The aerial lead connections are identified by figures 1, 2, 3.