

"TRADER" SERVICE SHEET

1071

PYE P53 & P53RC

Band-spread Superhets

EIGHT wavebands, including one trawler band and five band-spread S.W. bands, are provided in the Pye P53, a 4-valve superhet designed to operate from A.C. mains only of 200-250 V, 40-100 c/s. The waveband ranges are approximately 1,000-1,900 m, 200-550 m and 4-1.5 Mc/s (75-200 m, called MSW on this Service Sheet), and five band-spread ranges covering the 49 m, 31 m, 25 m, 19 m and 16 m bands. The P53RG is an autoradiogram with a 3-speed motor, and its chassis is like that in the P53 but with a number of modifications.

Release dates and original prices: P53, July 1951, £23 16s 3d; P53RG, August 1951, £64 14s 4d. Purchase tax extra.

CIRCUIT DESCRIPTION

On the three normal tuning bands the aerial is coupled by L2 (S.W.) and C3 (M.W. and L.W.) to single tuned circuits L3, C43 (S.W.), L4, C43 (M.W.) and L5, C43 (L.W.), which precede triode-hexode valve (V1, Mullard ECH42) operating as frequency-changer with internal

coupling. S20 closes on these bands to connect the aerial section of the gang C43.

On the five band-spread ranges S20 opens and S19 closes to connect the fixed capacitor C5 in place of C43, the aerial then being fixed-tuned to the centre of each band. The aerial is coupled by S19 and C4 to single-tuned circuits L6, C5 (49 m band), L7, C5 (31 m band), L8, C5 (25 m band), L9, C5 (19 m band) and L10, C5 (16 m band). I.F. filter L1, C1 is in circuit on all bands.

On the three normal waveband ranges, triode oscillator coils L13 (S.W.), L14 (M.W.) and L15 (L.W.) are tuned by C45. Parallel trimming by C15 (S.W.) and C44 (M.W.); series tracking by C13 (S.W.) and C14 (M.W.). Reaction coupling is effected on S.W. and M.W. from the grid circuit via the common impedance of the trackers, with the addition of inductive coupling by L11 (S.W.) and L12 (M.W.). On L.W., L15 is connected in a Colpitts circuit with C12, C17 and C45.

For band-spread operation, S59 opens and S26, S60 close. The band-spread oscillator coils L16 (49 m band), L17 (31 m band), L18 (25 m band), L19 (19 m band) and L20 (16 m band) are arranged in a Colpitts circuit with C12, C17, C18, C45 and C19. Tuning is performed by C45 via bandspreading capacitors C18, C19.

Second valve (V2, Mullard EF41) is a variable-

mu R.F. pentode, operating as intermediate frequency amplifier with tuned transformer couplings C7, L21, L22, C8 and C23, L23, L24, C24.

Intermediate frequency 470 kc/s.

Diode signal detector is part of double diode triode valve (V3, Mullard EBC41) and the audio frequency component in its rectified output, is developed across load resistors R8, R9.

With the waveband control in the gram position, the triode section of V1 operates as pick-up pre-amplifier. The pick-up output, which is shunted by C10, is connected via C9, S23 and S24 to the triode grid, and the amplified output developed across R7 is connected via C20, S61 to the lower end of the diode load, S62 opening on gram.

Second diode of V3 is fed via C28 from V2 anode and the resulting D.C. potential developed across load resistor R15 is fed back as bias to V1 and V2, giving automatic gain control.

Resistance-capacitance coupling by R13, C34 and R16 between V3 triode and pentode output valve (V4, Mullard EL41). Fixed tone correction in anode circuit by C36. Provision is made for the connection of a low impedance external speaker across T1 secondary.

A proportion of the speech coil voltage in T1

(Continued below circuit)

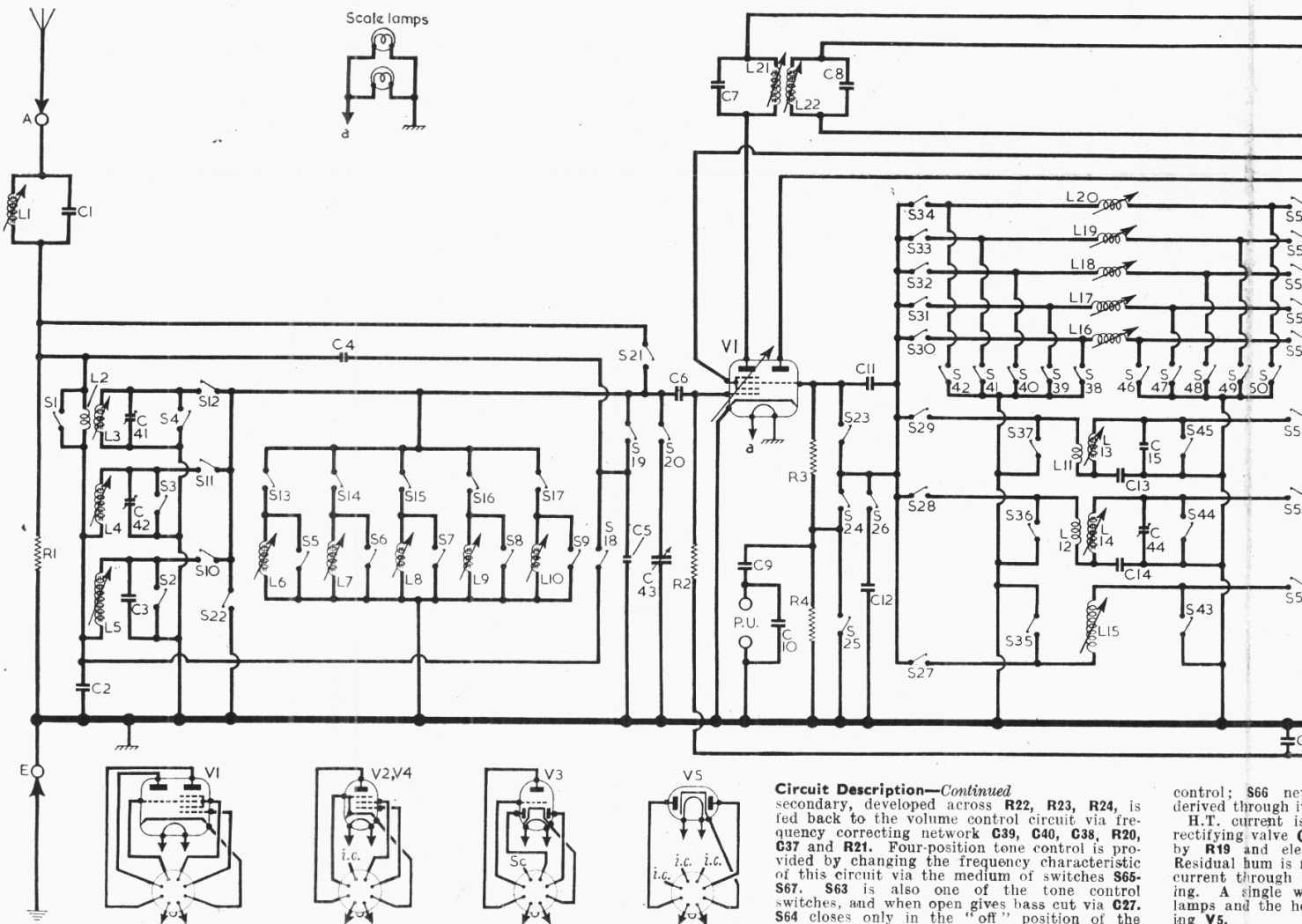

Circuit Description—Continued

secondary, developed across R22, R23, R24, is fed back to the volume control circuit via frequency correcting network C39, C40, C38, R20, C37 and R21. Four-position tone control is provided by changing the frequency characteristic of this circuit via the medium of switches S65-S67. S63 is also one of the tone control switches, and when open gives bass cut via C27. S64 closes only in the "off" position of the

control; S66 is derived through i... H.T. current is rectifying valve C... by R19 and ele... Residual hum is i... current through... ing. A single w... lamps and the h... ing V5.

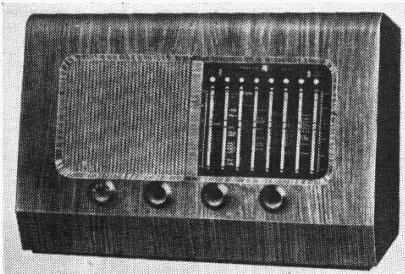

The Pye P53 band-spread superhet.

COMPONENTS AND VALUES

| CAPACITORS | | Values | Locations |
|------------|------------------------|----------------|-----------|
| C1 | I.F. filter tune ... | 0-001 μ F | B2 |
| C2 | Aerial coupling ... | 0-0024 μ F | H4 |
| C3 | L.W. aerial trim. ... | 120pF | H4 |
| C4 | Aerial coupling ... | 5-6pF | H4 |
| C5 | Band-spread tune ... | 62pF | H4 |
| C6 | V1 C.G. ... | 100pF | G4 |
| C7 | 1st I.F. trans. tuning | 100pF | C1 |
| C8 | | | C1 |
| C9 | P.U. coupling ... | 0-01 μ F | G4 |
| C10 | P.U. shunt ... | 0-01 μ F | G4 |

(Continued next col.)

| CAPACITORS <i>(continued)</i> | | Values | Locations |
|----------------------------------|--|----------------|-----------|
| C11 | V1 osc. C.G. ... | 100pF | H3 |
| C12 | Oscillator trimmer | 150pF | H3 |
| C13 | S.W. osc. tracker... | 0-0017 μ F | H3 |
| C14 | M.W. osc. tracker... | 360pF | H3 |
| C15 | S.W. osc. trimmer... | 27pF | H3 |
| C16 | A.G.C. decoupling | 0-04 μ F | G3 |
| C17 | Oscillator trimmer | 15pF | H3 |
| C18 | S.W. osc. band-spread capacitors | 150pF | H3 |
| C19 | | | H3 |
| C20 | Osc. anode coupling | 100pF | H3 |
| C21 | P.U. pre-amp. shunt | 0-01 μ F | G3 |
| C22 | S.G. decoupling ... | 0-05 μ F | G4 |
| C23 | 2nd I.F. trans. tuning | 100pF | C2 |
| C24 | ing ... | 100pF | C2 |
| C25 | I.F. by-pass ... | 100pF | F4 |
| C26 | A.F. coupling ... | 0-02 μ F | F3 |
| C27 | Part tone control ... | 0-005 μ F | E3 |
| C28 | A.G.C. coupling ... | 47pF | F4 |
| C29 | A.F. coupling ... | 0-04 μ F | F3 |
| C30* | H.T. decoupling ... | 16 μ F | C1 |
| C31* | H.T. smoothing | 32 μ F | D1 |
| C32* | | | D1 |
| C33 | I.F. by-pass ... | 100pF | F4 |
| C34 | A.F. coupling ... | 0-005 μ F | F3 |
| C35* | V4 cath. by-pass ... | 50 μ F | E4 |
| C36 | Tone corrector ... | 0-005 μ F | F4 |
| C37 | ing ... | 82pF | E3 |
| C38 | Parts of negative feed-back tone control circuit ... | 0-02 μ F | E3 |
| C39 | | | E4 |
| C40 | ing ... | 0-04 μ F | E3 |
| C41† | S.W. aerial trim. ... | 50pF | H4 |
| C42† | M.W. aerial trim. ... | 50pF | H4 |
| C43† | Aerial tuning ... | 528pF | A1 |
| C44† | M.W. osc. trim. ... | 50pF | H3 |
| C45† | Oscillator tuning ... | 528pF | A1 |

| RESISTORS | | Values | Locations |
|-----------|--|---------------|-----------|
| R1 | Aerial shunt ... | 22k Ω | B2 |
| R2 | V1 C.G. ... | 1M Ω | G4 |
| R3 | V1 osc. C.G. ... | 47k Ω | H3 |
| R4 | P.U. shunt ... | 10M Ω | G4 |
| R5 | Diode mute ... | 220k Ω | G3 |
| R6 | S.G. H.T. feed ... | 27k Ω | F3 |
| R7 | Osc. anode feed ... | 10k Ω | G3 |
| R8 | Diode load resistors | 220k Ω | F4 |
| R9 | | | F3 |
| R10 | Volume control ... | 1M Ω | F3 |
| R11 | V3 C.G. ... | 10M Ω | F4 |
| R12 | H.T. decoupling ... | 4-7k Ω | F4 |
| R13 | V3 anode load ... | 220k Ω | F4 |
| R14 | A.G.C. decoupling | 1M Ω | F4 |
| R15 | A.G.C. diode load ... | 1M Ω | F4 |
| R16 | V4 C.G. ... | 470k Ω | F4 |
| R17 | V4 C.G. stopper ... | 10k Ω | F4 |
| R18 | V4 G.B. ... | 180 Ω | F4 |
| R19 | H.T. smoothing ... | 1-6k Ω | E4 |
| R20 | ing ... | 2-2M Ω | E3 |
| R21 | Parts of negative feed-back tone control circuit ... | 390 Ω | E3 |
| R22 | | | E3 |
| R23 | | | E3 |
| R24 | | | E3 |

| OTHER COMPONENTS | | Approx. Values (ohms) | Locations |
|------------------|------------------------------------|-----------------------|-----------|
| L1 | I.F. filter ... | 2-0 | B2 |
| L2 | S.W. aerial coup. ... | 12-0 | H4 |
| L3- | Aerial and oscillator tuning coils | — | — |
| L20 | | | — |

(Continued col. 1 overleaf)

* Electrolytic. † Variable. ‡ Pre-set. § "Swing" value, min. to max.

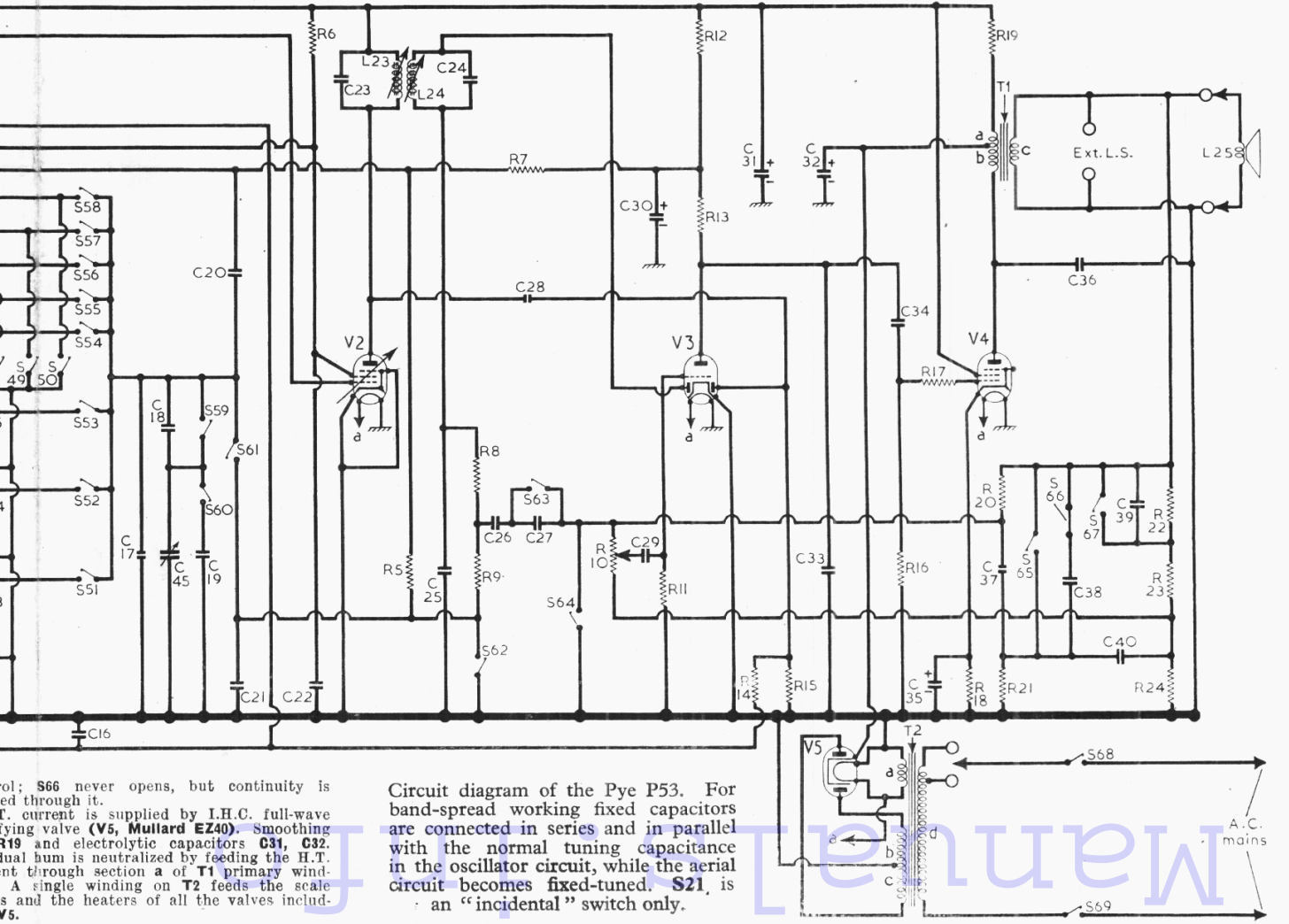

Circuit diagram of the Pye P53. For band-spread working fixed capacitors are connected in series and in parallel with the normal tuning capacitance in the oscillator circuit, while the aerial circuit becomes fixed-tuned. S21 is an "incidental" switch only.

| OTHER COMPONENTS (continued) | | Approx. Values (ohms) | Locations |
|---------------------------------|--|--------------------------|-----------|
| L21 | 1st I.F. trans. {Pri. {Sec. | 12-2 | C1 |
| L22 | | 12-2 | C1 |
| L23 | | 12-2 | C2 |
| L24 | 2nd I.F. trans. {Pri. {Sec. | 12-2 | C2 |
| L25 | | 2-5 | — |
| T1 | O.P. trans. {a ... {b ... {c ... | 15-0 | C1 |
| | | 485-0 | |
| | | — | |
| T2 | Mains trans. {a ... {b ... {c ... {d, total | 285-0 | D2 |
| | | 305-0 | |
| | | 38-0 | |
| | | — | |
| S1-S62 | Waveband switches | — | H3 |
| S63-S67 | Tone switches | — | E3 |
| S68, S69 | Mains sw., g'd tone control | — | E3 |

VALVE ANALYSIS

Valve voltages and currents given in the table below are those quoted by the manufacturers and were measured with the receiver operating from A.C. mains of 210 V, the voltage adjustment being set to the 200-220 V tapping. The receiver was tuned to the highest wavelength end of M.W., but there was no signal input.

Voltage readings were measured on the 10 V and 400 V ranges of a Model 7 Avometer, chassis being the negative connection.

| Valve | Anode | | Screen | | Cath. |
|----------|------------|------|--------|-----|--------|
| | V | mA | V | mA | |
| V1 ECH42 | 232 | 2.2 | 72 | 4.2 | — |
| | Oscillator | | | | |
| V2 EF41 | 150 | 4.6 | 72 | 1.7 | — |
| | 232 | 6.1 | | | |
| V3 EBC41 | 62 | 0.6 | — | — | — |
| V4 EL41 | 254 | 30.0 | 232 | 4.0 | 6.1 |
| V5 EZ40 | 500† | — | — | — | 268-0* |

† Anode to anode, A.C.
* Cathode current 53.4 mA.

GENERAL NOTES

Switches.—S1-S62 are the waveband and radio/gram change-over switches, ganged in three rotary units beneath the chassis. These are indicated in our underside chassis illustration, where they are identified by diamond-tailed arrows numbered 1, 2, 3. They are shown again in detail in the diagrams in col. 4, where they are drawn as seen from the rear of an inverted chassis.

The table in col. 6 gives the switch positions for the nine control settings, starting from the fully anti-clockwise position of the control knob. A dash indicates open, and C, closed.

Tuning drive cord systems for the two models. On the left, that of the P53, and on the right that of the P53RG. In both cases they are drawn as seen from the rear with the gang at maximum.

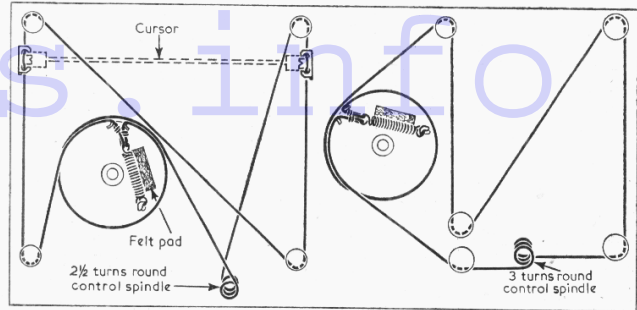

S63-S67 are the tone control switches, ganged in a single rotary unit beneath the chassis. This unit is shown in detail in the diagram in col. 5, and has its own table of switch action for the five settings (col. 4). With this unit is ganged the double-pole Q.M.B. mains switch unit S68, S69, which opens in the fully anti-clockwise position of the control. As in the case of the waveband switch table, a dash indicates open, and C, closed.

S64 occurs incidentally in the construction of the switch unit, and closes only in the "off" position of the control. S66 is not a switch at all, as it remains closed throughout the range of control. We show it because it forms part of the connecting link between C38 and say R22.

Scale Lamps.—These are two lamps, with large spherical bulbs, and M.E.S. bases, rated at 6.5 V, 0.3 A. The bulbs are normally dipped in white paint.

External Speaker.—Two pairs of sockets are provided at the rear of the chassis for the connection of the internal and an external speaker. The impedance of an external speaker should be low, about 2-4 Ω.

RADIOGRAM MODIFICATIONS

The principal changes in the chassis of the P53RG autoradiogram as compared with the P53 chassis on which our circuit diagram is based concern the pick-up input circuit and the negative feedback circuit.

In the radiogram the triode section of V1 is not used as a pick-up amplifier, the pick-up output being fed in directly to the junction of R9 and S62. Pick-up sockets are still used, and in series with them in place of C9 is a 220 kΩ resistor, the other side of it being shunted by a 500 pF capacitor in place of C10. R5 is connected at its H.T. positive end to the other end of R7, and its value is changed to 10 MΩ. C21 is omitted altogether.

Slight changes occur in the waveband switching. Two lamps which floodlight the gramophone compartment of the cabinet are connected to the heater supply at one end and to S23 at the other, the upper end of S23 in our diagram going to the lamps instead of to V1 triode grid. The lower end of S23 still goes to S24, but the

lower end of S24 is connected to chassis, not to S25.

The upper end of R20, which we show connected to S65, S67, goes instead to the junction of R22, R23; that is to say, the other side of S67. The value of C39 becomes 0.5 μF, R22 becomes 22 kΩ, and C34 becomes 0.1 μF.

CIRCUIT ALIGNMENT

I.F. Stages.—Remove the chassis from the cabinet, switch receiver to M.W., turn gang and volume control to maximum. Connect output of signal generator, via an 0.1 μF capacitor in the "live" lead, to control grid (pin 6) of V1 and chassis. Feed in a 470 kc/s (G38.3 m) signal and adjust the cores of L24 (location reference C2), L23 (G4), L22 (C1) and L21 (G3) for maximum output.

I.F. Filter.—With the receiver tuned to the highest wavelength end of M.W., connect the signal generator output, via a standard dummy aerial, to A and E sockets. Feed in a 470 kc/s signal and adjust the core of L1 (B2) for minimum output.

R.F. and Oscillator Stages.—As the tuning scale is mounted in the cabinet, and the following adjustments have to be carried out with the chassis on the bench, reference is made during alignment to a substitute tuning scale printed on the rear left-hand side (viewed from rear of chassis) edge of the scale backing plate. This scale has 100 divisions and it is read off against the lower edge of the cursor carriage.

With the gang at maximum capacitance the reading on the substitute scale should be 100, and if any error is found, the cursor carriage can be slid up or down the drive cord to correct it. When the chassis is inserted in the cabinet, the cursor should coincide with the black dots at the highest wavelength ends of the scales with the gang at maximum capacitance. The signal generator output should be connected via a standard dummy aerial to the A and E sockets.

L.W.—Switch receiver to L.W., tune to 1,400 m (55 on substitute scale), feed in a 1,400 m (214 kc/s) signal and adjust the cores of L15 (H4) and L5 (H4) for maximum output.

M.W.—Switch receiver to M.W., tune to 500 m

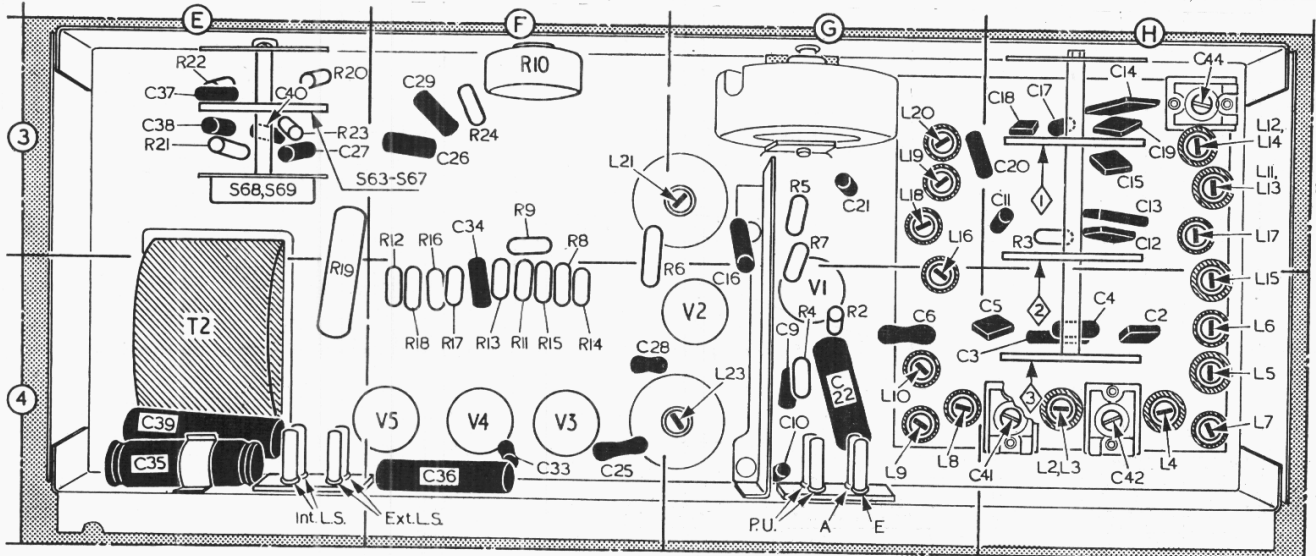

Underside view of the chassis. Detailed diagrams of the three waveband switch units are shown in col. 3.

| Switch | Off | F | B | M | S |
|--------|-----|---|---|---|---|
| S63 | ... | C | — | — | — |
| S64 | ... | C | — | — | — |
| S65 | ... | C | — | — | — |
| S66 | ... | C | C | — | C |
| S67 | ... | C | — | — | C |

Tone control switch table for the unit whose diagram appears in col. 4.

(82 on scale), feed in a 500 m (600 kc/s) signal and adjust the cores of **L14** (H3) and **L4** (H4) for maximum output. Tune receiver to 200 m (10 on scale), feed in a 200 m (1,500 kc/s) signal and adjust **C44** (H3) and **C42** (H4) for maximum output. Repeat these adjustments until calibration is correct.

S.W.—Switch receiver to M.S.W., tune to 200 m (10 on scale), feed in a 200 m (1,500 kc/s) signal and adjust the cores of **L13** (H3) and **L3** (H4) for maximum output. Tune receiver to 3.3 Mc/s (28 on scale), feed in a 90.9 m (3.3 Mc/s) signal and adjust **C41** (H4) for maximum output. Repeat these adjustments until calibration is correct.

49 m band.—Switch receiver to 49 m, tune to 6.1 Mc/s (50.5 on scale), feed in a 6.1 Mc/s (49.18 m) signal and adjust the cores of **L16** (G3) and **L6** (H4) for maximum output.

31 m band.—Switch receiver to 31 m, tune to 9.6 Mc/s (50 on scale), feed in a 9.6 Mc/s (31.25 m) signal and adjust the cores of **L17** (H3) and **L7** (H4) for maximum output.

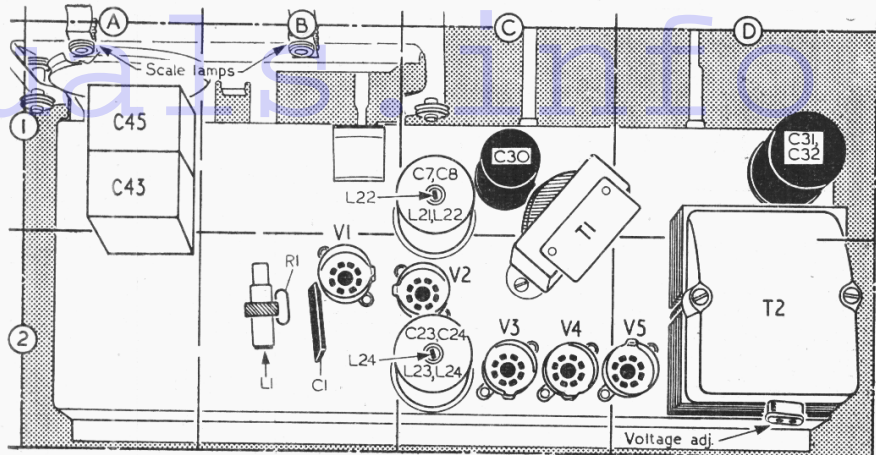

Plan view of the chassis.

25 m band.—Switch receiver to 25 m, tune to 11.8 Mc/s (50 on scale), feed in an 11.8 Mc/s (25.42 m) signal and adjust the cores of **L18** (G3) and **L8** (G4) for maximum output.

19 m band.—Switch receiver to 19 m, tune to 15.3 Mc/s (50 on scale), feed in a 15.3 Mc/s (19.61 m) signal and adjust the cores of **L19** (G3) and **L9** (G4) for maximum output.

16 m band.—Switch receiver to 16 m, tune to 17.8 Mc/s (50 on scale), feed in a 17.8 Mc/s (16.85 m) signal and adjust the cores of **L20** (G3) and **L10** (G4) for maximum output.

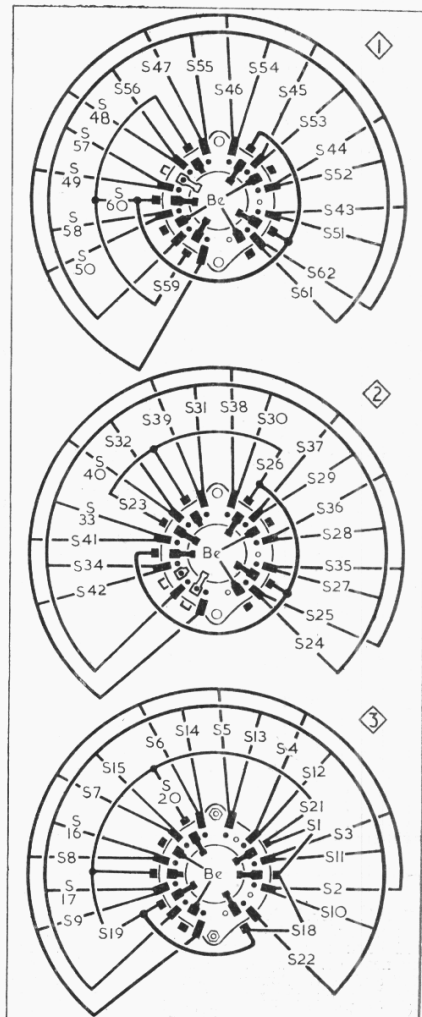

DRIVE CORD REPLACEMENT

About five feet of nylon braided glass yarn is required for a new drive cord in either model, and it should be run as shown in the sketches seen at the head of cols. 2 and 3, where the systems are shown separately for the table model (on the left) and the radiogram (on the right). The makers quote the exact cord lengths as 51 inches and 50 inches respectively for the two models, measured between the centres of the end loops when made up in advance. Both ends are looped on to the tension spring, and it is possible to fit the made-up loop of cord with the ends already attached to it.

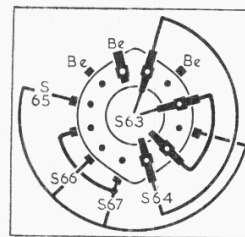

Left: Diagrams of the waveband switch units, drawn as seen from the rear of an inverted chassis. On the right is the associated table. Above: Diagram of the tone control switch unit. Its table of operation appears at the head of col. 4.

| Switch | Gram. | L.W. | M.W. | S.W. | 49m | 31m | 25m | 19m | 16m |
|--------|-------|------|------|------|-----|-----|-----|-----|-----|
| S1 | — | C | — | — | — | — | — | — | — |
| S2 | — | — | C | — | — | — | — | — | — |
| S3 | — | — | — | C | — | — | — | — | — |
| S4 | — | — | — | — | C | — | — | — | — |
| S5 | — | — | — | — | — | C | — | — | — |
| S6 | — | — | — | — | — | — | C | — | — |
| S7 | — | — | — | — | — | — | — | C | — |
| S8 | — | — | — | — | — | — | — | — | C |
| S9 | — | — | — | — | — | — | — | — | — |
| S10 | — | — | — | — | — | — | — | — | — |
| S11 | — | — | — | — | — | — | — | — | — |
| S12 | — | — | — | — | — | — | — | — | — |
| S13 | — | — | — | — | — | — | — | — | — |
| S14 | — | — | — | — | — | — | — | — | — |
| S15 | — | — | — | — | — | — | — | — | — |
| S16 | — | — | — | — | — | — | — | — | — |
| S17 | — | — | — | — | — | — | — | — | — |
| S18 | — | — | — | — | — | — | — | — | — |
| S19 | — | — | — | — | — | — | — | — | — |
| S20 | — | — | — | — | — | — | — | — | — |
| S21 | — | — | — | — | — | — | — | — | — |
| S22 | — | — | — | — | — | — | — | — | — |
| S23 | — | — | — | — | — | — | — | — | — |
| S24 | — | — | — | — | — | — | — | — | — |
| S25 | — | — | — | — | — | — | — | — | — |
| S26 | — | — | — | — | — | — | — | — | — |
| S27 | — | — | — | — | — | — | — | — | — |
| S28 | — | — | — | — | — | — | — | — | — |
| S29 | — | — | — | — | — | — | — | — | — |
| S30 | — | — | — | — | — | — | — | — | — |
| S31 | — | — | — | — | — | — | — | — | — |
| S32 | — | — | — | — | — | — | — | — | — |
| S33 | — | — | — | — | — | — | — | — | — |
| S34 | — | — | — | — | — | — | — | — | — |
| S35 | — | — | — | — | — | — | — | — | — |
| S36 | — | — | — | — | — | — | — | — | — |
| S37 | — | — | — | — | — | — | — | — | — |
| S38 | — | — | — | — | — | — | — | — | — |
| S39 | — | — | — | — | — | — | — | — | — |
| S40 | — | — | — | — | — | — | — | — | — |
| S41 | — | — | — | — | — | — | — | — | — |
| S42 | — | — | — | — | — | — | — | — | — |
| S43 | — | — | — | — | — | — | — | — | — |
| S44 | — | — | — | — | — | — | — | — | — |
| S45 | — | — | — | — | — | — | — | — | — |
| S46 | — | — | — | — | — | — | — | — | — |
| S47 | — | — | — | — | — | — | — | — | — |
| S48 | — | — | — | — | — | — | — | — | — |
| S49 | — | — | — | — | — | — | — | — | — |
| S50 | — | — | — | — | — | — | — | — | — |
| S51 | — | — | — | — | — | — | — | — | — |
| S52 | — | — | — | — | — | — | — | — | — |
| S53 | — | — | — | — | — | — | — | — | — |
| S54 | — | — | — | — | — | — | — | — | — |
| S55 | — | — | — | — | — | — | — | — | — |
| S56 | — | — | — | — | — | — | — | — | — |
| S57 | — | — | — | — | — | — | — | — | — |
| S58 | — | — | — | — | — | — | — | — | — |
| S59 | — | — | — | — | — | — | — | — | — |
| S60 | — | — | — | — | — | — | — | — | — |
| S61 | — | — | — | — | — | — | — | — | — |
| S62 | — | — | — | — | — | — | — | — | — |