

"TRADER" SERVICE SHEET
995

EKCO U122

Portable A.C./D.C. Superhet

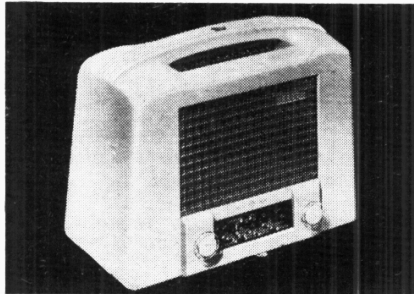

The Ekco U122 portable.

COMPACT in design, the chassis of the Ekco U122 is provided with supports which permit it to be stood on any of its six sides. It is removed from its plastic case upon removal of eight screws.

The receiver is a 4-valve (plus rectifier) 2-band superhet designed to operate from A.C. or D.C. mains of 115-250 V, although the 115 V tapping is normally masked to prevent accidents. A thermistor is provided to prevent current surges in the heater circuit.

Release date and original price: July, 1950; £12 1s 7d. Purchase tax extra.

CIRCUIT DESCRIPTION

Tuned frame aerial input **L1, C30** (M.W.) and **L2, C30** (L.W.) precede triode-hexode valve (**V1, Mullard UCH42**) which operates as frequency changer with internal coupling. Provision is made for the connection of an external aerial via a tap on **L1**.

On L.W. **L1** is shunted by **C4, R2** to form a band-pass coupling circuit with **L2, C3**. **R2** damps the R.F. response of this circuit to give a level overall characteristic.

Oscillator grid coils **L3** (M.W.) and **L4** (L.W.) are tuned by **C31**. Parallel trimming by **C32** (M.W.); series tracking by **C10** (M.W.) and **C11**

(L.W.). Inductive reaction coupling from anode by **L5** (M.W.) and **L6** (L.W.).

Second valve (**V2, Mullard UF41**) is a variable- μ R.F. pentode operating as intermediate frequency amplifier with tuned transformer couplings **C6, L7, L8, C7** and **C15, L9, L10, C16**.

Intermediate frequency 470 kc/s. Diode signal detector is part of double diode triode valve (**V3, Mullard UBC41**). A.F. component in rectified output is developed across volume control **R9**, which acts as diode load, and is passed via I.F. stopper **R11** and coupling capacitor **C20** to the grid of the triode section.

(Continued overleaf)

COMPONENTS AND VALUES

CAPACITORS		Values	Locations
C1	Aerial series	50pF	A2
C2	Chassis isolator	0.05 μ F	G4
C3	L.W. aerial trim.	50pF	C2
C4	L1 shunt	0.001 μ F	B2
C5	V1 C.G.	300pF	F4
C6	1st I.F. trans.	56pF	A2
C7	tune	56pF	A2
C8	V1 osc. C.G.	100pF	F3
C9	R.F. by-pass	0.1 μ F	G4
C10	M.W. tracker	560pF	F4
C11	L.W. tracker	345pF	G4
C12	A.G.C. decoupling	0.1 μ F	A1
C13	L.W. osc. trim.	195pF	B1
C14	Osc. anode coup.	0.001 μ F	A1
C15	2nd I.F. trans.	100pF	B2
C16	tune	100pF	B2
C17	I.F. by-pass	100pF	B2
C18	Neg. feed-back	50pF	E3
C19	A.G.C. coupling	15pF	E4
C20	A.F. coupling	0.01 μ F	E4
C21	H.T. decoupling	0.1 μ F	E4
C22	Tone corrector	0.01 μ F	F4
C23*	H.T. smoothing	20 μ F	C1
C24	A.F. coupling	0.01 μ F	E4
C25*	H.T. decoupling	2 μ F	E4
C26	Neg. feed-back	0.002 μ F	D4
C27	Tone corrector	0.01 μ F	D4
C28*	H.T. smoothing	50 μ F	D1
C29	Mains R.F. filter	0.05 μ F	C1
C30†	Aerial tuning	—	A2
C31†	Oscillator tuning	—	A2
C32‡	M.W. osc. trim.	—	G3

RESISTORS		Values	Locations
R1	Damping resistors	4.7k Ω	A2
R2		100 Ω	B2
R3		470k Ω	F4
R4	V1 osc. C.G.	47k Ω	F4
R5	V1 osc. H.T. feed	33k Ω	F4
R6	Common G.B.	39 Ω	D3
R7		68 Ω	D3
R8	Scale lamp shunt	150 Ω *	D3
R9	Volume control	500k Ω	E3
R10	A.G.C. decoupling	1M Ω	E4
R11	I.F. stopper	47k Ω	E3
R12	V3 C.G.	10M Ω	E4
R13	Brimistor, type CZ2	—	C2
R14	H.T. decoupling	1k Ω	F4
R15	V3 anode load	100k Ω	E4
R16	A.G.C. diode load	1M Ω	E4
R17	Heater ballast	888 Ω †	C2
R18	H.T. pot. divider	10k Ω	E4
R19		33k Ω	E3
R20		3.3k Ω	E4
R21	Neg. feed-back	560k Ω	E4
R22	V4 C.G.	1M Ω	D4
R23	V5 surge limiter	70 Ω	C1

* Electrolytic. † Variable. ‡ Pre-set.

* Two 330 Ω resistors are used in parallel. † Tapped at 670+90+128 Ω from R13.

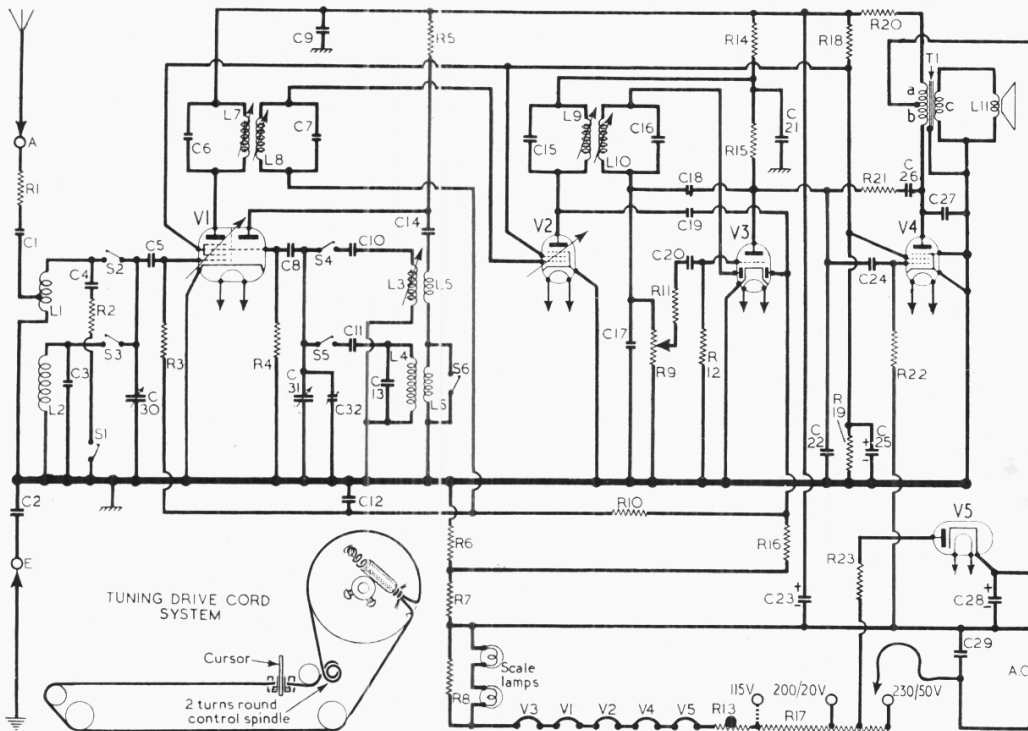

Circuit diagram of the Ekco U122. Just beneath this caption is inset a diagram of the waveband switch unit. Inset beneath the circuit is a sketch of the tuning drive system.

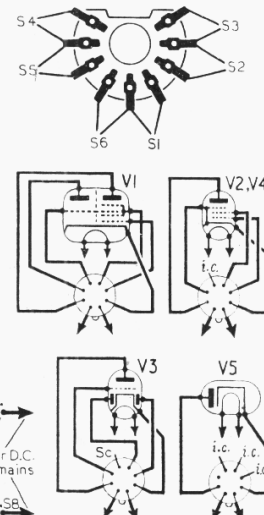

OTHER COMPONENTS		Approx. Values (ohms)	Locations
L1	M.W. frame aerial...	1.0*	A2
L2	L.W. frame aerial...	10.0	A2
L3	Oscillator tuning coils	3.0	A1
L4	coils	6.8	A1
L5	Oscillator reaction coils	2.0	A1
L6	coils	5.3	A1
L7	1st I.F. trans. { Pri. ...	26.0	A2
L8	trans. { Sec. ...	26.0	A2
L9	2nd I.F. Pri. ...	16.0	B2
L10	trans. { Sec. ...	16.0	B2
L11	Speech coil	2.5	B1
T1	O.P. trans. { a ...	160.0	A1
	{ b ...	190.0	
	{ c ...	0.3	
S1-S6	Waveband switches	—	B1
S7, S8	Mains sw., g'd R9...	—	E3

* 0.5Ω each half.

Circuit Description—continued

Negative feed-back between triode anode and grid circuit via C18.

Second diode of V3, fed from V2 anode via C19, provides D.C. potential which is developed across load resistor R16 and is applied as bias to F.C. and I.F. stages, giving automatic gain control. I.F. filtering by C17.

Resistance-capacitance coupling via R15, C24 and R22 between V3 triode anode and pentode output valve (V4, Mullard UL41). Tone correction by C22 and C27, and by negative feedback via C26, R21 and C18 between anode and grid circuits of V4 and V3.

H.T. current is supplied by I.H.C. rectifying valve (V5, Mullard UY41). Smoothing by R20 and electrolytic capacitors C23, C28, residual hum being neutralized by passing the current through part of the primary winding of the output transformer T1. Bias for V1, V2 is obtained from the voltage drop across R6, and that for V4 is obtained from the voltage drop across R6, R7, in series with the negative lead to chassis.

Valve heaters, together with scale lamps, surge limiting resistor R13 and ballast resistor R17, are connected in series across the mains input. R23 protects V5 from current surges. R.F. filtering by C29.

CIRCUIT ALIGNMENT

To facilitate these adjustments, remove the chassis from the cabinet and stand it on one end, so that the top and under-chassis sides are accessible.

I.F. Stages.—Switch set to M.W., turn gang to maximum and connect signal generator leads, via a 0.1 μF capacitor in the "live" lead, to control grid (pin 6) of V1. Feed in a 470 kc/s (638.3 m) signal and adjust the cores of L10 (location reference B2), L9 (E4), L8 (A2) and L7 (F4) for maximum output. Repeat these adjustments.

R.F. and Oscillator Stages.—Transfer signal generator leads via a suitable dummy aerial to A and E sockets. Check that with the gang at

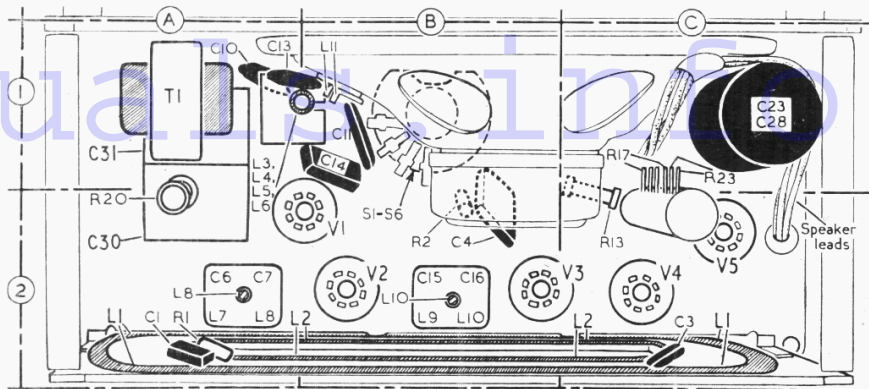

Plan view of the chassis, drawn as seen with the speaker and frame aerials in position. Several components are dotted through the speaker.

maximum capacitance the cursor coincides with the vertical scale mark at the high wavelength end of M.W. scale.

M.W.—Tune set to 250 m, feed in a 250 m (1,200 kc/s) signal and adjust C32 (G3) for maximum output. Tune set to 352.9 m, feed in a 352.9 m (850 kc/s) signal and adjust the core of L3 (F3) to the peak at which the adjusting screw is the more fully exposed. Repeat these adjustments.

L.W.—There are no adjustments to be made on L.W., and provided that the M.W. alignment has been correctly carried out, the L.W. calibration should be satisfactory.

DISMANTLING THE SET

Removing Chassis.—Lay the receiver face downwards on the bench and remove the four screws (with washers) holding the moulded feet to the corners of the underside of the receiver, and lift off the bottom cover.

The underside of the chassis is now completely exposed, but the chassis, complete with speaker, control knobs and frame aerials, can be withdrawn upon removal of the four hexagon posts on to which the feet were screwed. Each has a paxolin washer. A 2BA box spanner fits the posts.

GENERAL NOTES

Switches.—S1-S6 are the waveband switches, ganged in a lever-operated 2-position rotary unit mounted on the chassis deck. This is indicated in our plan view of the chassis, and shown in detail in the diagram inset in the upper right-hand corner of our circuit diagram overleaf. In the M.W. position of the unit (control lever to left), the even-numbered switches close; in the L.W. position the odd-numbered switches close.

S7, S8 are the Q.M.B. mains switches, ganged with the volume control R9.

Scale Lamps.—These are two Osram lamps, with small clear spherical bulbs and M.E.S.

bases, rated at 6.0 V, 0.06 A. To remove them for replacement it is necessary first to remove the tuning scale and its escutcheon.

This is done by pulling off the two control knobs (with plastic bevelled washers) and then removing the two 6BA countersunk screws which are thus revealed, when the scale and escutcheon come away together.

Mains Voltage Adjustment.—The heater circuit ballast resistor R17 carries two tapping connections for 200-220 V and 230-250 V mains, and these are brought out to a panel beneath the chassis with a screw-in plug. A third socket is fitted to the panel, and this is connected to a tapping at the far end of R17 for use on low-voltage mains around 115 V, but normally this socket is covered with adhesive tape.

It is important to bear in mind that this socket is provided, however, because it is not at all obvious when covered up. The reason for covering it, of course, is to prevent uninformed users from accidentally inserting the plug in it when adjusting the receiver themselves.

Ballast Resistor.—The unit carrying R17 also carries R23, which is isolated from it in manufacture and connected externally to a tapping point on R17 by means of an external lead.

Divergency.—In early versions of this receiver, V3 anode decoupling components R14, C21 were not used.

Drive Cord Replacement.—The drive cord forms a loop of plaited flax fishing line about 22 inches long circumferentially. Allowing a comfortable margin for tying off, about 30 inches is required for a new cord. It should be run as shown in the sketch inset beneath the circuit diagram overleaf, where the system is drawn as seen from the front with the gang at maximum capacitance.

Access is gained to the tuning drive system by removing the scale escutcheon as described under "Scale Lamps," and then removing the speaker baffle, which is held by four 6BA screws. These screw into the uprights with a flat washer under their heads, and a lock-nut is run on finally. It is unnecessary to disconnect the speaker leads, but when replacing, the earthing tag goes under the top right-hand screw.

VALVE ANALYSIS

Valve voltages and currents given in the table below are those quoted by the manufacturer, and were taken when the receiver was operating from 225 V A.C. mains.

Voltages were measured on a 1,000 ohms per volt meter, chassis being the negative connection. The voltage reading on V5 cathode was 218 V.

Valve	Anode		Screen	
	V	mA	V	mA
V1 UCH42	158	2.1	76	2.0
V2 UF41	73	2.6	76	1.25
V3 UBC41	155	4.5	—	—
V4 UL41	76	0.7	76	2.35
V5 UY41	213	25.5	—	—
	215†	—	—	—

† A.C. volts.

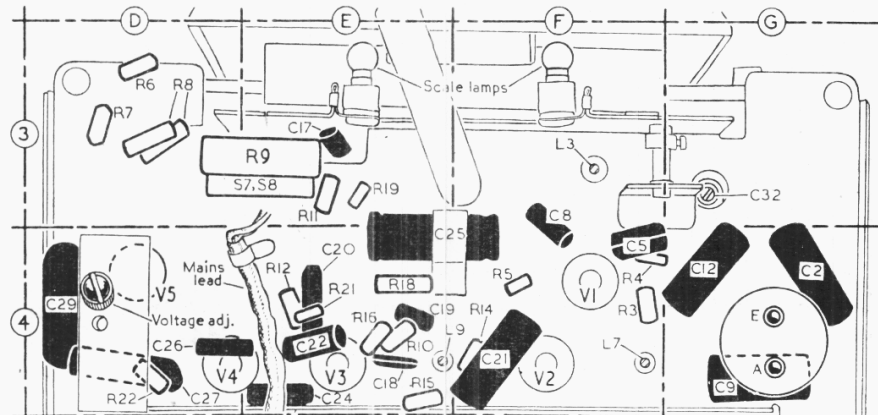

Underside view of the chassis. The voltage adjustment screw is in the 230-250 V position, with the 200-220 V socket below it. Below that again is the 115 V socket, covered with tape.