

"TRADER" SERVICE SHEET

383

# FERGUSON 702 AND 705 RADIOGRAM

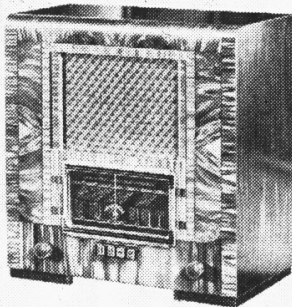

The Ferguson model 702.

**P**RESS-BUTTONS for wave-change and gramophone switching are included in the Ferguson 702 6-valve (plus rectifier) AC 3-band superhet. The receiver is suitable for mains of 200-250 V, 50-60 C/S, and has a short-wave range of 16-50 m, a cathode-ray tuning indicator and provision for both a gramophone pick-up and an extension speaker.

An identical chassis is fitted in the 705 radiogram but this *Service Sheet* was prepared on a 702.

Release date for both models: August, 1938.

### CIRCUIT DESCRIPTION

Aerial input is fed on MW and LW via series condenser **C1** to coupling condensers **C2, C3**, via switch **S1**, that fraction of the signal voltage which is developed across

**C3** being coupled to the tuning coils **L3** (MW) and **L4** (LW), which are tuned by **C32**. On SW, input is via **C1** and coupling condensers **C2, C4** to single tuned circuit **L2, C32, S1** then being open.

Resistance **R3** is connected between **V1** tetrode CG and **L3** to prevent the grid becoming free during the process of switching. **L1, R1** are included across the aerial circuit to suppress modulation hum.

First valve (**V1, Brimar 6A8G**) is a heptode operating as frequency changer with electron coupling. Oscillator grid coils **L5** (SW), **L6** (MW) and **L7** (LW) are tuned by **C33**; parallel trimming by **C34** (SW), **C35** (MW) and **C7, C36** (LW); series tracking by **C37** (SW), **C38** (MW) and **C39** (LW). Reaction by coils **L8** (SW), **L9** (MW) and direct coupling via **C8** (LW). **R8** is the oscillator CG resistance, but **R5** is connected directly between the CG and chassis to prevent the grid from becoming free during the process of switching.

Second valve (**V2, Brimar 6U7G**) is a variable-mu RF pentode operating as intermediate frequency amplifier with tuned-primary tuned-secondary transformer couplings **C40, L10, L11, C41** and **C42, L12, L13, C43**.

### Intermediate frequency 465 KC/S.

Diode second detector is part of double diode triode valve (**V3, Mullard 6Q7G**), both diode anodes being strapped together. Audio frequency component in rectified output is developed across load resistance **R12** and passed via IF stopper **R13**, AF coupling condenser **C16**, manual volume control **R15** and further AF coupling condenser **C17**, to CG of triode section, which operates as AF amplifier. IF filtering by **C13, R13, C14**, in diode circuit,

**C18** in grid circuit and **C19** in anode circuit. Variable tone control by **C20, R18** in anode circuit. Provision for connection of pick-up across **C16, R15** via **S10**.

DC potential developed across **R12** is fed back through decoupling circuits as GB to FC (except on SW) and IF valves, giving automatic volume control. This potential, taken from the junction of **L11, R10**, is also used to control the cathode ray tuning indicator (**T.I., Mullard 6G5**).

Resistance-capacity coupling by **R17, C23, R24** between **V3** triode and one side of push-pull output stage comprising two beam tetrode valves (**V5, V6, Mullard 6V6G's**). The other side, **V5**, is fed via phase reversing valve (**V4, Mullard 6C5G**) which obtains its input from junction of **R20, R21**, which form a step-down coupling to balance the valve gain. Provision is made for connection of external speaker between **V5, V6** anodes.

HT current is supplied by full-wave rectifying valve (**V7, Mullard 5Y3G**). Smoothing by speaker field **L16** and dry electrolytic condensers **C25, C26**.

GB potential for **V3** triode and **V4** is automatically obtained from drop along **R28** in negative HT lead to chassis.

### DISMANTLING THE SET

**Removing Chassis.**—Remove the two control knobs and the four buttons (pull off) and the four bolts (each with two washers and a spring washer) holding the chassis to the bottom of the cabinet, when the chassis can be withdrawn to the extent of the speaker leads, which is sufficient for normal purposes.

**When replacing,** fit the buttons in the following order from left to right:—Gram, SW, MW, LW, see that the buttons

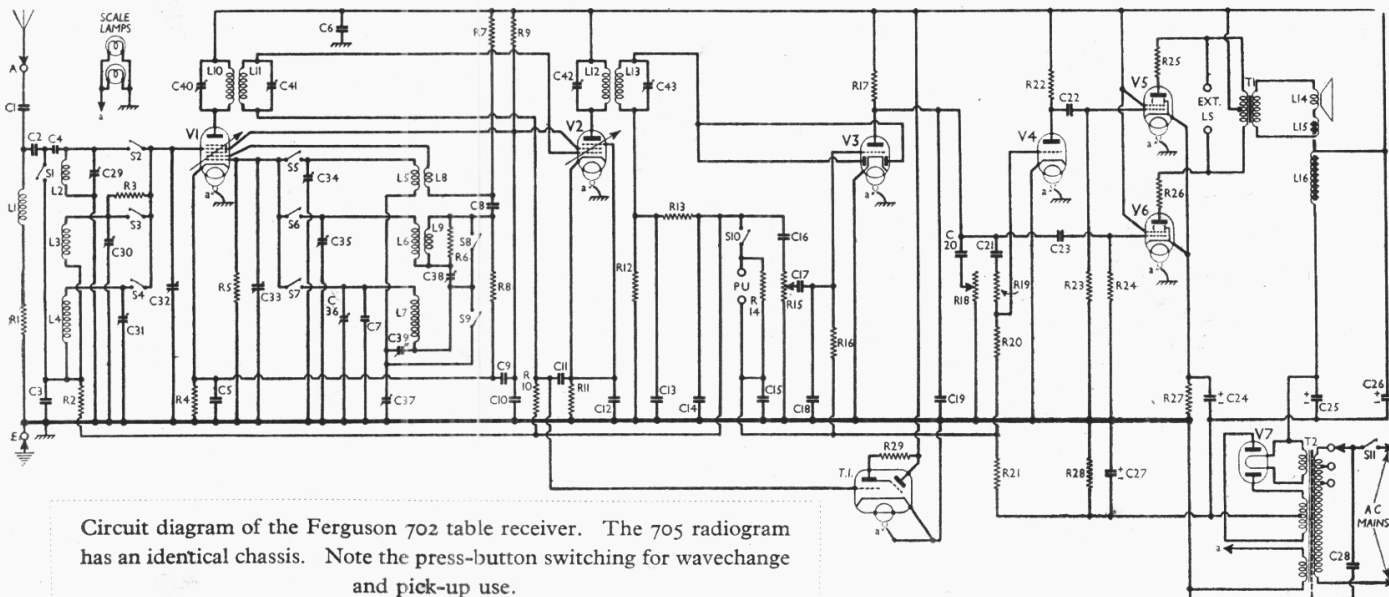

Circuit diagram of the Ferguson 702 table receiver. The 705 radiogram has an identical chassis. Note the press-button switching for wavechange and pick-up use.

Under-chassis view. Diagrams of the press-button switch unit are in col. 3 overleaf. C34-C36 are in a row above the unit, while C29-C31 are in a row beneath it. The trackers C37-C39 are adjustable through holes in the chassis deck.

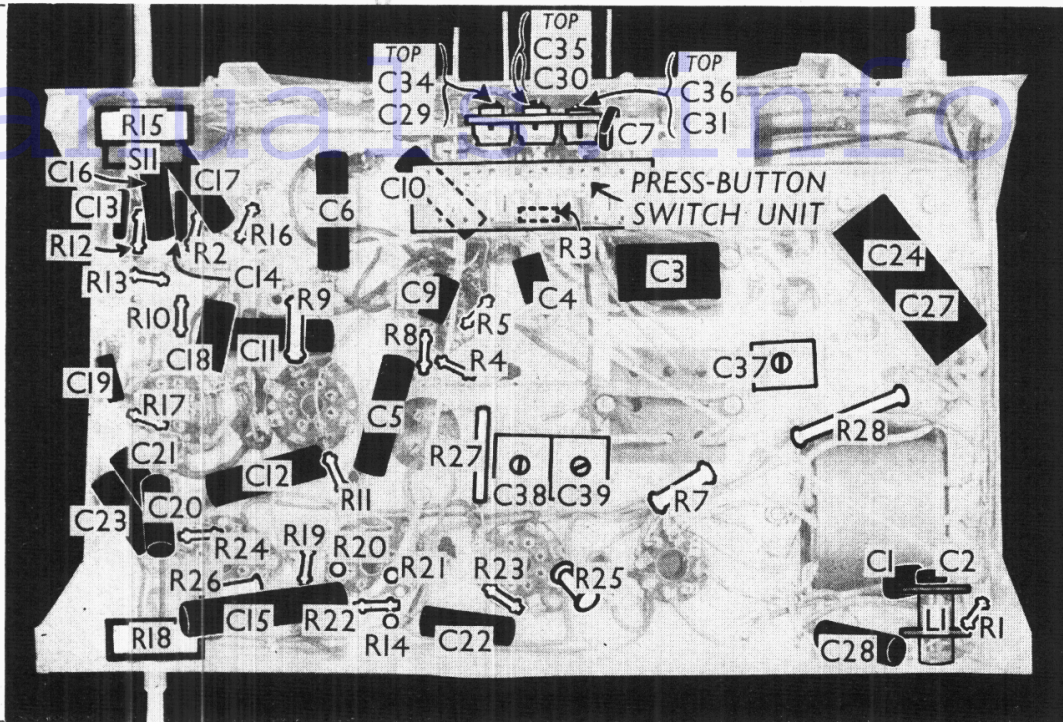

do not foul the escutcheon and do not forget to replace the felt washers on the spindles of the rotary controls.

To free the chassis entirely, unsolder the speaker leads and when replacing, connect them as follows, numbering the tags from bottom to top:—1, red/yellow; 2, black; 3 and 5 joined together, brown; 4, black.

**Removing Speaker.**—The speaker can be removed from the cabinet by unsoldering the leads and removing the nuts from the four screws holding it to the sub-baffle. When replacing, see that the transformer is on the left and connect the leads as above.

**COMPONENTS AND VALUES**

CONDENSERS		Values (μF)
C1	Aerial series condenser	0.0005
C2	Aerial circuit MW and LW coupling potential divider	0.0001
C3	Aerial SW coupling condenser	0.0004
C4	V1 cathode by-pass	0.00002
C5	HT circuit RF by-pass	0.1
C6	V1 osc. anode coupling	0.1
C7	V1 SG RF by-pass	0.00007
C8	V1, V2 SG's decoupling	0.00026
C9	V2 CG decoupling	0.00025
C10	V2 cathode by-pass	0.1
C11	IF by-pass condensers	0.00025
C12	V3 triode and V4 CG's decoupling	0.00025
C13	AF coupling condensers to V3 triode	0.02
C14	IF by-pass condensers	0.00015
C15	Part of variable tone control	0.00025
C16	V3 triode to V4 AF coupling	0.01
C17	V4 to V5 AF coupling	0.01
C18	V3 triode to V6 AF coupling	0.01
C19	V5, V6 cathodes-by-pass	5.0
C20	HT smoothing	16.0
C21	Auto GB circuit by-pass	8.0
C22	Mains RF by-pass	25.0
C23	Aerial SW trimmer	0.01
C24	Aerial circuit MW trimmer	—
C25	Aerial circuit LW trimmer	—
C26	Oscillator circuit tuning	—
C27	Osc. circuit MW trimmer	—
C28	Osc. circuit LW trimmer	—
C29	Osc. circuit SW tracker	—
C30	Osc. circuit MW tracker	—
C31	Osc. circuit LW tracker	—
C32	1st IF trans. pri. trimmer	—
C33	1st IF trans. sec. trimmer	—
C34	2nd IF trans. pri. trimmer	—
C35	2nd IF trans. sec. trimmer	—
C36	Speaker speech coil	2.0
C37	Hum neutralising coil	0.15
C38	Speaker field coil	1,000.0
C39	Speaker input (Pri., total trans.)	660.0

CONDENSERS (Continued)		Values (μF)
C31†	Aerial circuit LW trimmer	—
C32†	Aerial circuit tuning	—
C33†	Oscillator circuit tuning	—
C34†	Osc. circuit SW trimmer	—
C35†	Osc. circuit MW trimmer	—
C36†	Osc. circuit LW trimmer	—
C37†	Osc. circuit SW tracker	—
C38†	Osc. circuit MW tracker	—
C39†	Osc. circuit LW tracker	—
C40†	1st IF trans. pri. trimmer	—
C41†	1st IF trans. sec. trimmer	—
C42†	2nd IF trans. pri. trimmer	—
C43†	2nd IF trans. sec. trimmer	—

\* Electrolytic. † Variable. ‡ Pre-set.

RESISTANCES		Values (ohms)
R1	Anti-modulation choke damping	10,000
R2	V1 tetrode CG decoupling	500,000
R3	V1 tetrode CG resistance	3,000,000
R4	V1 fixed GB resistance	150
R5	V1 osc. CG resistance	500,000
R6	Osc. circuit MW reaction damping	2,500
R7	V1 osc. anode HT feed resistance	25,000
R8	V1 osc. CG resistance	50,000
R9	V1, V2 SG's HT feed resistance	25,000
R10	V2 and T.I. CG's decoupling	500,000
R11	V2 fixed GB resistance	300
R12	V3 diodes load resistance	500,000
R13	IF stopper	25,000
R14	Gramophone PU shunt	25,000
R15	Manual volume control	500,000
R16	V3 triode CG resistance	500,000
R17	V3 triode anode load	250,000
R18	Variable tone control	100,000
R19	V4 CG input pot. divider	500,000
R20	V3 triode and V4 CG's decoupling	35,000
R21	V3 triode and V4 CG's decoupling	250,000
R22	V4 anode load resistance	250,000
R23	V5 CG resistance	500,000
R24	V6 CG resistance	500,000
R25	V5 anode RF stopper	100
R26	V6 anode RF stopper	100
R27	V5, V6 GB resistance	300
R28	V3 triode and V4 auto GB resistance	25
R29	T.I. anode HT feed	250,000

OTHER COMPONENTS		Approx. Values (ohms)
L1	Aerial anti-modulation choke	20.0
L2	Aerial circuit SW tuning coil	0.1
L3	Aerial circuit MW tuning coil	3.0
L4	Aerial circuit LW tuning coil	17.0
L5	Osc. circuit SW tuning coil	0.1
L6	Osc. circuit LW tuning coil	3.0
L7	Osc. circuit MW tuning coil	5.0
L8	Oscillator SW reaction coil	0.5
L9	Oscillator MW reaction coil	1.0
L10	1st IF trans. (Pri.)	9.0
L11	1st IF trans. (Sec.)	11.0
L12	2nd IF trans. (Pri.)	12.0
L13	2nd IF trans. (Sec.)	9.0
L14	Speaker speech coil	2.0
L15	Hum neutralising coil	0.15
L16	Speaker field coil	1,000.0
T1	Speaker input (Pri., total trans.)	660.0
T2	Mains (Heater sec., Rect. heat. sec., HT sec., total)	0.5, 17.5, 0.05, 0.1, 200.0
S1-S9	Waveband switches	—
S10	Gram. pick-up switch	—
S11	Mains switch, ganged R15	—

**VALVE ANALYSIS**

Valve	Anode Voltage (V)	Anode Current (mA)	Screen Voltage (V)	Screen Current (mA)
V1 6A8G	{ 248 134	{ 6.2 4.0	100	3.6
V2 6U7G	248	7.5	100	2.2
V3 6Q7G	102	0.4	—	—
V4 6C5G	48	0.8	—	—
V5 6V6G	235	28.0	248	1.5
V6 6V6G	235	28.0	248	1.5
V7 5Y3G	328†	—	—	—
T.I. 6G5	{ 38 248	{ 0.8 1.9	—	—

† Each anode, AC.

Valve voltages and currents given in the table above are those measured in our receiver when it was operating on mains of 228 V, using the 220-230 V tapping on the mains transformer. The receiver was

tuned to the lowest wavelength on the medium band and the volume control was at maximum. There was no signal input.

Voltages were measured on the 400 V scale of a model 7 Universal Avometer, chassis being negative.

If, as in our case, **V2** should become unstable when its anode and screen currents are being measured, it can be stabilised by connecting a non-inductive condenser of about 0.1  $\mu\text{F}$  from the electrode concerned to chassis.

**GENERAL NOTES**

**Switches.**—All the switches, with the exception of **S11**, the mains switch, are of the press-button type, and are contained in a single double-sided unit mounted inside the front of the chassis.

The switch unit is indicated in our underchassis view, but for identification of the individual switches the diagrams in col. 3 must be consulted. The upper diagram of the two shows the switches seen when looking at the underside of the chassis, while the lower one shows the switches on the unit which are normally hidden from view by the chassis deck.

To examine these, the whole switch unit must be removed. To do this, remove the screws holding the two banks of three trimmers (above and below the switch unit) and the two screws holding the unit to the chassis and gently ease the unit out, taking care not to break any connections.

The table (col. 2) gives the switches which are closed and open when each button is depressed.

**S11** is the QMB mains switch, ganged with the volume control **R15**.

**Coils.**—**L1** is beneath the chassis, close to the aerial lead entry point. **L2-L4**; **L5-L9** and the IF transformers **L10, L11** and **L12, L13** are in four screened units on the chassis deck. The second unit also contains **R6, C8**, while the IF units contain their associated trimmers.

**Scale Lamps.**—These are two National Union miniature bayonet cap types, marked N51. The rating is presumably 6.8 V, 0.3 A.

**External Speaker.**—Two sockets are

**TABLE AND DIAGRAMS OF THE SWITCH UNITS**

Button	Closed	Open
LW	S1, S4, S7, S8	S2, S3, S5, S6, S9, S10
MW	S1, S3, S6, S9	S2, S4, S5, S7, S8, S10
SW	S2, S5, S8, S9	S1, S3, S4, S6, S7, S10
Gram.	S1, S8, S9, S10	S2, S3, S4, S5, S6, S7

provided at the rear of the chassis for a high impedance (10,000  $\Omega$ ) speaker.

**Condensers C25, C26.**—These are two dry electrolytics in a single tubular metal case on the chassis deck. Beneath the chassis there are three tags. The plain one is the common negative; that spotted red is the positive of **C25** (16  $\mu\text{F}$ ); while that spotted yellow is the positive of **C26** (8  $\mu\text{F}$ ).

**Condensers C24, C27.**—These are two dry electrolytics (35 V working) in a single carton beneath the chassis, having a common negative (black) lead. The red lead is the positive of **C24** (5  $\mu\text{F}$ ), while the yellow is the positive of **C27** (25  $\mu\text{F}$ ).

**Trimmers.**—The aerial circuit trimmers (**C29-C31**) are in a row below the press-button switch unit (looking from the underside of the chassis), while the oscillator circuit trimmers (**C34-C36**) are in a similar row above the switch unit. All six trimmers are adjustable through holes in the front of the chassis.

**Trackers.**—The three variable trackers (**C37-C39**) are mounted beneath the chassis, and are adjustable through holes in the chassis deck.

**Chassis Divergencies.**—**C7** and **R8** are not shown on the makers' diagram. The common negative of **C24** and **C27** goes to chassis in the makers' diagram, but in our model it was connected to the HT negative line as shown in our circuit. The makers' diagram shows an extra 0.00025  $\mu\text{F}$  condenser across **C19**, but this was not in our chassis.

**RADIOGRAM 705 MODIFICATIONS**

The only difference in the 705 radiogram (apart from the inclusion of a 2,000  $\Omega$  pick-up and a motor) is that the speaker is

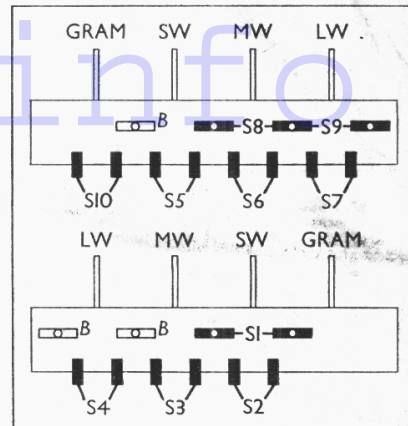

Diagrams of both sides of the switch unit. The upper one shows the switches seen from the underside of the chassis, while the lower one shows those on the side nearest the chassis deck.

a 10-in. model, instead of the 8-in. model used in the 702. Its resistance values remain the same.

**CIRCUIT ALIGNMENT**

**IF Stages.**—Remove the grid (top cap) connection of **V1**, and connect a 0.5 MO resistor between the connection and the cap. Connect signal generator between the cap. (via a 0.00025  $\mu\text{F}$  condenser) and chassis. Switch set to MW, and turn gang and volume control to maximum.

Feed in a 465 KC/S signal, and adjust **C43, C42, C41** and **C40** for maximum output. Re-check, then remove the 0.5 MO resistor and replace top cap.

**RF and Oscillator Stages.**—With the gang at maximum, pointer should be at the right hand terminations of the horizontal scales. Connect signal generator to **A** and **E** leads, via a suitable dummy aerial. Turn volume control to maximum.

**SW.**—Since the SW tracker is in series with the MW and LW trackers it is essential to align the SW band first.

Switch set to SW, tune to 15 MC/S on scale, and feed in a 15 MC/S (20 m) signal. Adjust **C34** for maximum output, using the peak involving the least trimmer capacity. Now adjust **C29** for maximum.

Feed in a 6 MC/S (50 m) signal, tune it in, and adjust **C37** for maximum output, while rocking the gang for optimum results. Return to 15 MC/S and re-check **C29** and **C34**. Repeat until no further improvement results.

**MW.**—Switch set to MW and tune to 250 m on scale. Feed in a 250 m (1,200 KC/S) signal, and adjust **C35**, then **C30** for maximum output. Feed in a 520 m (580 KC/S) signal, tune it in, and adjust **C38** for maximum output, while rocking the gang for optimum results. Return to 250 m and re-check **C35** and **C30**. Repeat until no further improvement results.

**LW.**—Switch set to LW, and tune to 1,250 m on scale. Feed in a 1,250 m (240 KC/S) signal, and adjust **C36**, then **C31**, for maximum output. Feed in a 2,000 m (150 KC/S) signal, tune it in, and adjust **C39** for maximum output, while rocking the gang for optimum results. Return to 1,250 m and re-check **C36** and **C31**. Repeat until no further improvement results.

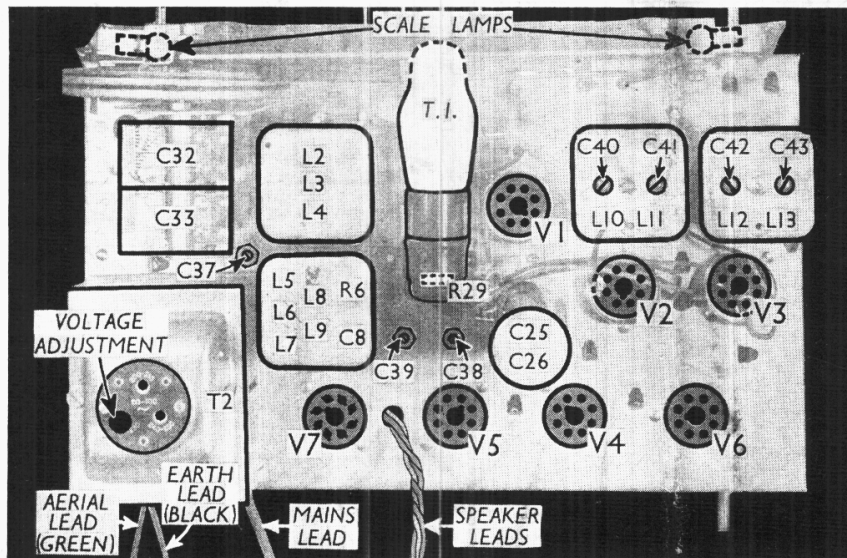

Plan view of the chassis. Note the adjustments for the trackers **C37-C39**. **R29** is inside the T.I. holder.