

'TRADER' SERVICE SHEET

356

# MARCONIPHONE 571, 572 AND 573

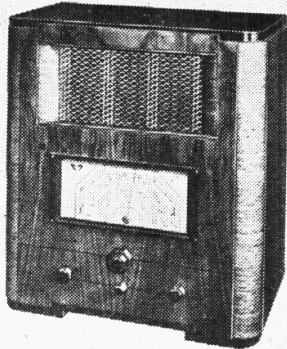

The Marconiphone 571

A SHORT-WAVE range of 16.8-52 m is covered by the Marconiphone 571 5-valve (plus rectifier) AC/DC 3-band superhet. It is suitable for mains of 105-255 V (40-100 C/S in the case of AC) and includes a cathode-ray tuning indicator.

A similar chassis is fitted in the 572 radiogram and 573 radiogram with record changer, but these are for 40-60 C/S in the case of AC supplies, owing to the limitation imposed by the motor. The differences are given under "572 and 573 Modifications."

This Service Sheet was prepared on a 571 table model.

### CIRCUIT DESCRIPTION

The aerial socket is connected via series condenser C1, which reduces the aerial loading and isolates the aerial from the mains, directly to aerial tuning circuit comprising tuning coils L1 (SW), plus L2 (MW), plus L3 (LW) and tuning condenser C41 which precedes first valve (V1, Marconi KTW63 or W63), a variable-

mu RF tetrode or pentode operating as signal frequency amplifier.

One side of the split earth socket E is connected via isolating condenser C3 to chassis, the other side being connected to L10, speaker grille and frame and other exposed metal parts including the metal casing (via pin 4 of the interconnecting plug) of the mains resistance unit. The two halves of E are connected only when the earth connecting plug is inserted.

Tuned-anode coupling by L4 (SW), plus L5 (MW), plus L6 (LW), tuned by C44 between V1 and heptode valve (V2, Marconi X63) operating as frequency changer with electron coupling. Oscillator grid coils L3 (SW), plus L9 (MW), plus L10 (LW) are tuned by C45; parallel trimming by C46 (SW), C47 (MW) and C9, C49 (LW); series tracking by C10 (SW), C11, C48 (MW) and C50 (LW). Reaction by coils L11 (SW), L12 (MW) and L13 (LW).

Third valve (V3, Marconi KTW63 or W63) is a variable-mu RF tetrode or pentode operating as intermediate frequency amplifier with tuned-primary tuned-secondary transformer couplings C51, L14, L15, R4, C52 and C53, L16, L17, C54.

Intermediate frequency 465 KC/S.

Diode second detector is part of double-diode triode valve (V4, Marconi DH63). Audio frequency component in rectified output is developed across load resistance R11 and passed via IF stopper R9, AF coupling condenser C21 and S10 (on MW and LW) or C21, C23, S11 (on SW) and manual volume control R10 to CG of triode section, which operates as AF amplifier. IF filtering by C27 in anode circuit, and R9, C22.

Second diode of V4, fed from V3 anode via C20, provides DC potentials which are developed across load resistances R14, R15, R16, R17 and fed back through decoupling circuits as GB to RF, FC and IF valves, giving automatic volume control. Delay voltage is obtained mainly from potential divider comprising resistances R18, R19 which are connected in series between V1, V3's HT feed line and chassis, this HT line in turn being fed from another potential divider comprising resistances R20, R21, R22, R23.

The balance of the delay voltage is obtained from the drop automatically developed across R28 in negative HT lead to chassis, this additional voltage also providing fixed GB for V1, V2 and V3.

Control grid potentials for cathode-ray tuning indicator (T.I. Marconi Y63 or TI64) are obtained from V1, V2 AVC line.

Resistance-capacity coupling by R13, C28, R24, via grid stopper R25, between V4 triode and beam tetrode output valve (V5, Marconi KT32). Variable condenser C55 coupling anode and grid circuits provides variable tone control, while C31 in anode circuit provides fixed tone correction. Provision for connection of low impedance external speaker across secondary of output transformer T1.

When the receiver is used with AC mains, HT current is supplied by IHC half-wave rectifying valve (V6, Marconi U31). Smoothing is effected by two iron-cored chokes L18, L20 and dry electrolytic condensers C29, C32, C33.

Valve heaters are connected in series, together with scale lamps and voltage adjustment resistance R29, across mains input. Filter comprising chokes L21, L22 and condensers C36, C37, and C35 in rectifier anode circuit, suppress mains-borne interference, while fuses F1, F2 guard against accidental short-circuits.

Special provision has been made in the design of the receiver to render it operative over a voltage range of 105 to 255 V on AC or DC mains, and the voltage adjustment arrangements are more elaborate than usual. In addition to the usual heater circuit ballast adjustment, provision is made for simultaneously adjusting the voltage applied to V6 anode so that it coincides with mains voltage up to the 162-180 V tapping, after which it rises no further. At the same time provision is made for adjusting the point at which HT is applied to the potential divider R20, R21, R22, R23, so that for mains voltages between 144 V and 255 V, R20 is connected to L18 as shown in our diagram, but for voltages between 105 V and 143 V the junction of R21, R22 is connected to L18.

In operation, these adjustments are automatically effected by the three-pin voltage adjustment plug.

### DISMANTLING THE SET

A detachable bottom is fitted to the cabinet and upon removal (three round-head wood screws) gives access to most of the components beneath the chassis.

Removing Chassis.—If it is necessary to remove the chassis from the cabinet, remove the small tuning and tone control knobs (recessed grub screws covered with wax), the large tuning knob (pull off) and the other two knobs (recessed self-tapping screws covered with wax). Then free the speaker leads from the cleat on the

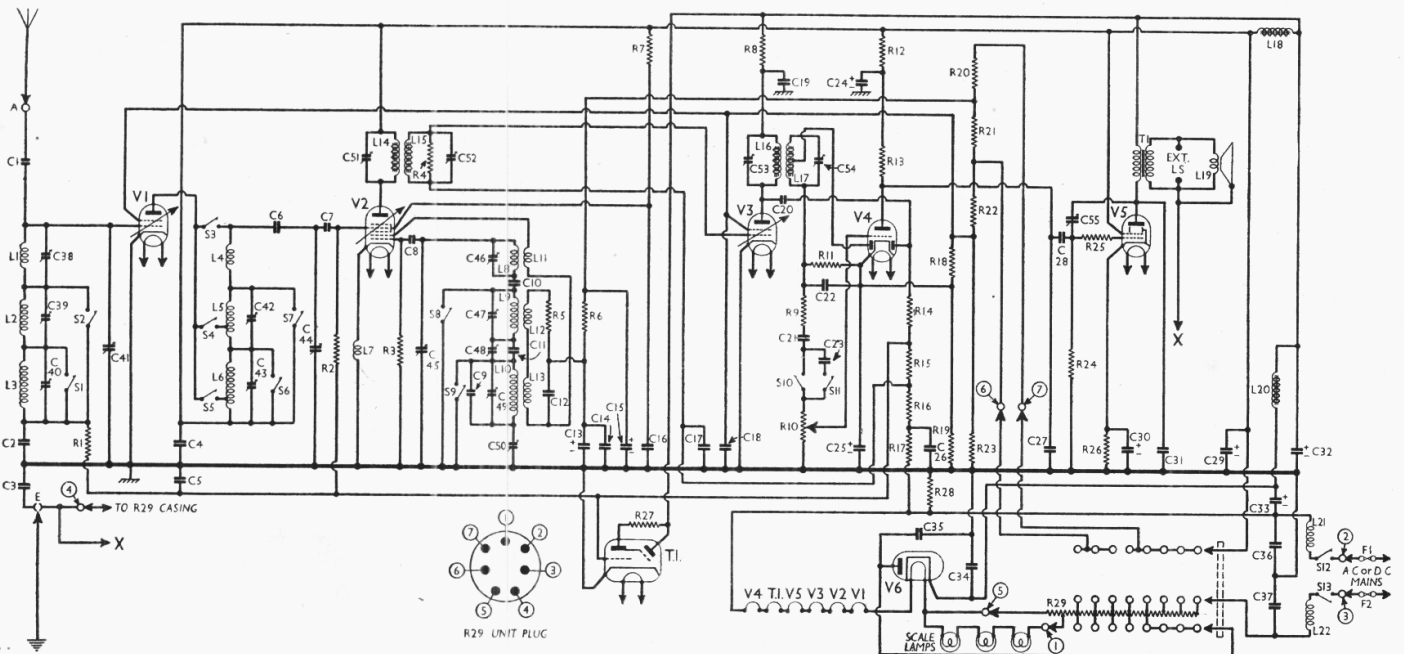

Circuit diagram of the Marconiphone 571 AC/DC superhet. The differences in the radiograms 572 and 573 are given on page VIII. Note the unusual mains voltage adjustment arrangements.

For more information remember  
[www.savoy-hill.co.uk](http://www.savoy-hill.co.uk)

sub-baffle, unplug the lead from the mains resistance to the socket on the chassis, withdraw the mains voltage adjustment plug and remove the earthing tag on the rear member of the chassis (round-head self-tapping screw).

Next remove the four bolts (with washers and spring washers) holding the chassis to the bottom of the cabinet, when the chassis can be withdrawn to the extent of the leads, which is sufficient for normal purposes. When replacing, cover the heads of the screws in the control knobs with wax, and if the valves have been removed, note that the top cap screen goes on V4.

If it is desired to operate the chassis outside the cabinet, the mains resistance must be removed from the brackets holding it to the side of the cabinet (four round-head screws with lock washers) and connected up to the chassis. When replacing, do not forget to secure the tag for the earthing lead to the speaker grille to one of the bottom fixing screws.

To free the chassis entirely, unsolder the speaker leads and when replacing, connect the black lead to the right-hand tag.

**Removing Speaker.**—To remove the speaker from the cabinet, unsolder the leads and remove the four screws (with washers) holding it to the sub-baffle. When replacing, see that the terminal panel is at the bottom, do not forget to replace the earthing tag on the bottom right-hand fixing screw, and take the black lead from the chassis to the right-hand tag.

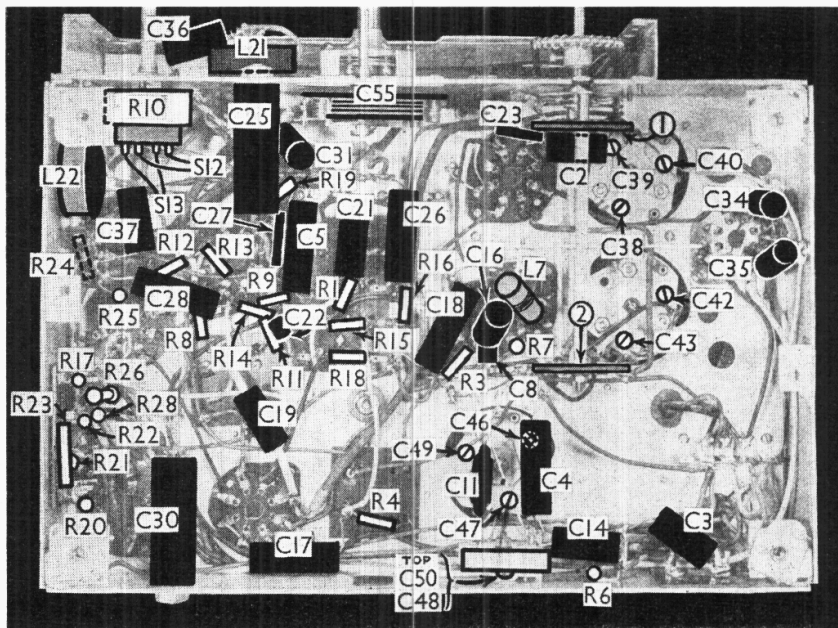

Under-chassis view. Switch diagrams are on page VIII. Note the screw heads of the various trimmers.

**COMPONENTS AND VALUES**

RESISTANCES		Values (ohms)
R1	V1 CG decoupling ..	75,000
R2	V2 tetrode CG resistance ..	500,000
R3	V2 osc. CG resistance ..	50,000
R4	1st IF trans. sec. shunt ..	750,000
R5	Oscillator reaction stabiliser ..	100
R6	V2 osc. anode HT feed ..	1,000
R7	V2 SG HT feed ..	35,000
R8	V3 anode HT feed ..	5,000
R9	IF stopper ..	100,000
R10	Manual volume control ..	2,000,000
R11	V4 signal diode load ..	500,000
R12	V4 triode anode decoupling ..	35,000
R13	V4 triode anode load ..	75,000
R14	V4 AVC diode load resistances ..	750,000
R15		230,000
R16		500,000
R17	V4 triode GB and AVC delay potential divider ..	100,000
R19		1,000
R20	V1, V3 SG HT feed; V4 cathode pot. feed; V2 osc. anode HT feed potential divider resistances ..	1,500
R21		1,500
R22		3,500
R23		15,000
R24	V5 CG resistance ..	350,000
R25	V5 grid stopper ..	50,000
R26	V5 GB resistance ..	100
R27	T.I. anode HT feed ..	500,000
R28	V1, V2, V3 fixed GB resistance ..	23
R29	Voltage adjustment resistance, total ..	458.5*

\* 64 Ω + 54 Ω + 61 Ω + 62 Ω + 40 Ω + 55 Ω + 37 Ω + 17.5 Ω + 68 Ω, starting from free end.

CONDENSERS		Values (μF)
C1	Aerial series condenser ..	0.000075
C2	V1 CG decoupling ..	0.05
C3	Earth isolating condenser ..	0.0005
C4	V1, V2, V4 HT line RF by-pass ..	0.1
C5	AVC line decoupling ..	0.1
C6	HT blocking condenser ..	0.1
C7	V2 tetrode CG condenser ..	0.000035
C8	V2 osc. CG condenser ..	0.00005
C9	Osc. circuit LW fixed trimmer ..	0.000015
C10	Osc. circuit SW tracker ..	0.00035
C11	Osc. circuit MW fixed tracker ..	0.00035
C12	Osc. SW reaction coupling ..	0.0001
C13*	V2 osc. anode decoupling ..	4.0
C14	V2 osc. anode RF by-pass ..	0.005
C15*	V2 osc. anode decoupling ..	4.0
C16	V2 SG decoupling ..	0.05
C17	V3 CG decoupling ..	0.1
C18	V1, V3 SG's decoupling ..	0.1
C19	V3 anode decoupling ..	0.05
C20	Coupling to V4 AVC diode ..	0.000075
C21	MW and LW AF coupling to V4 triode ..	0.005
C22	IF by-pass ..	0.0001
C23	SW AF coupling to V4 triode ..	0.001
C24*	V4 triode anode decoupling ..	1.0
C25*	V4 cathode by-pass ..	50
C26	V4 AVC diode RF by-pass ..	0.1
C27	IF by-pass ..	0.0005
C28	V4 triode to V5 AF coupling ..	0.035
C29*	Part HT smoothing ..	8.0
C30*	V5 cathode by-pass ..	50.0
C31	Fixed tone corrector ..	0.0023

CONDENSERS (Continued)		Values (μF)
C32*	Parts HT smoothing ..	32.0
C33*	V6 cathode RF by-pass ..	16.0
C34	V6 anode RF by-pass ..	0.05
C35		0.05
C36	Mains RF filter condensers ..	0.01
C37		0.01
C38†	Aerial circuit SW trimmer ..	—
C39†	Aerial circuit MW trimmer ..	—
C40†	Aerial circuit LW trimmer ..	—
C41†	Aerial circuit tuning ..	—
C42†	V1 anode MW trimmer ..	—
C43†	V1 anode LW trimmer ..	—
C44†	V1 anode circuit tuning ..	—
C45†	Oscillator circuit tuning ..	—
C46†	Osc. circuit SW trimmer ..	—
C47†	Osc. circuit MW trimmer ..	—
C48†	Osc. circuit MW tracker ..	—
C49†	Osc. circuit LW trimmer ..	—
C50†	Osc. circuit LW tracker ..	—
C51†	1st IF trans. pri. tuning ..	—
C52†	1st IF trans. sec. tuning ..	—
C53†	2nd IF trans. pri. tuning ..	—
C54†	2nd IF trans. sec. tuning ..	—
C55†	Variable tone control ..	0.0005

\* Electrolytic. † Variable. ‡ Pre-set.

OTHER COMPONENTS		Approx. Values (ohms)
L1	Aerial SW tuning coil ..	0.1
L2	Aerial MW tuning coil ..	6.0
L3	Aerial LW tuning coil ..	14.0
L4	V1 anode SW tuning coil ..	0.1
L5	V1 anode MW tuning coil ..	5.5
L6	V1 anode LW tuning coil ..	14.0
L7	V2 cathode frequency stabiliser ..	0.1
L8	Osc. circuit SW tuning coil ..	0.1
L9	Osc. circuit MW tuning coil ..	5.5
L10	Osc. circuit LW tuning coil ..	4.2
L11	Osc. SW reaction coil ..	1.0
L12	Osc. MW reaction coil ..	2.0
L13	Osc. LW reaction coil ..	3.0
L14	1st IF trans. { Pri... ..	6.3
L15	{ Sec... ..	6.3
L16	2nd IF trans. { Pri... ..	6.3
L17	{ Sec... ..	6.3
L18	Part HT smoothing ..	550.0
L19	Speaker speech coil ..	4.0
L20	Part HT smoothing ..	65.0
L21	Mains RF filter chokes ..	3.0
L22		3.0
T1	Output trans. { Pri... ..	180.0
	{ Sec... ..	0.9
St-Sr11	Waveband switches ..	—
Sr2,13	Mains switches, ganged Rro ..	—
Fr,F2	Mains circuit fuses ..	—

**VALVE ANALYSIS**

Valve voltages and currents given in the table below are those measured in our receiver when it was operating on AC mains of 228 V, using the 210-230 V tapping on the mains resistance. The receiver was tuned to the lowest wavelength on the medium band and the volume control was at maximum, but there was no signal input.

Voltages were measured on the 400 V scale of a model 7 Universal Avometer, chassis being negative.

If, as in our case, V2 should become unstable when its anode current is being measured and V3 when its screen current is being measured, they can be stabilised by connecting a non-inductive condenser of about 0.1 μF from grid (top cap) to chassis.

Valve	Anode Voltage (V)	Anode Current (mA)	Screen Voltage (V)	Screen Current (mA)
V1 KTW63	117	3.9	65	1.0
V2 X63	117	1.5	52	1.9
	Oscillator	95		
V3 KTW63	105	4.4	65	1.2
V4 DH63	60	0.4	—	—
V5 KT32	119	54.0	117	4.0
V6 U31	†	—	—	—
T.I. Y64	{ 22 Target	0.2	—	—
	{ 130	0.3	—	—

† Cathode to chassis. 138 V, DC

**GENERAL NOTES**

In examining the table receiver chassis, it will be found that the wiring for a gramophone pick-up and for its switching is carried out, but no pick-up sockets are fitted. The leads which would connect to them are actually connected to chassis and to a blank (bearer) socket on V3 valve-holder. Although the gramophone switches are included in the switch units, and are wired up, they are not used, a stop being fitted to limit the travel of the switches to the three radio wavebands.

Hence the extra switches and wiring are not shown in our diagrams.

**Switches.**—S1-S11 are the waveband switches, in two rotary units beneath the chassis. These are indicated in our under-chassis view, and shown in detail in the diagrams on page VIII. The table (page VIII) gives the switch positions for the three control settings, starting from fully anti-clockwise. A dash indicates open, and C, closed.

As explained above, certain tags, which would form radio gram switches, are wired up, but they are not included in the diagrams, the tags being marked bearer (Be).

Continued overleaf

MARCONIPHONE 571—Continued

TABLE AND DIAGRAMS OF THE SWITCH UNITS

SWITCH	LW	MW	SW
S1	—	C	—
S2	—	—	C
S3	—	—	—
S4	—	C	—
S5	C	—	—
S6	—	C	—
S7	—	—	C
S8	—	—	C
S9	—	C	—
S10	C	C	—
S11	—	—	C

S12, S13 are the QMB mains switches, ganged with the volume control R10.

**Coils.** L1-L3, L4-L6, L8-L13, and the IF transformers L14, L15 and L16, L17 are in five screened units on the chassis deck. Most of these contain additional components as indicated in our plan chassis view. L7 is a small coil on a tubular former beneath the chassis.

**Scale Lamps.**—These are three Bulgin MES types, rated at 8 V, 0.15 A. They are connected in series in the heater circuit, and are shunted by a portion of R29.

**Fuses F1, F2.**—These are two 1½ in. glass tubular types, mounted in clips on the mains input resistance. They are rated at 1.25 A each.

**External Speaker.**—Two tags are provided on the internal speaker connection panel for a low impedance (5 Ω) external speaker.

**Condensers C13, C15, C24, C29, C32, C33.**—These are six dry electrolytics in a single metal-cased unit on the chassis deck. The case is isolated. The red lead is the positive of C33 (16 μF) and the black lead is its negative. The brown lead is the common negative of all the other condensers. Their positive leads are: yellow, C32 (32 μF); green, C29 (8 μF); blue to junction of R6 and C14, C13 (4 μF); blue to R6, R20 and R21, C15 (4 μF); white, C24 (1 μF).

**Voltage Adjustment.**—A special and rather elaborate form of mains voltage adjustment is provided to enable the set to work efficiently on voltages as low as 105 V. The arrangement is given in detail at the end of "Circuit Description."

The mains adjustment resistance R29 has a number of tappings, and is enclosed in a metal case, fixed inside the cabinet. It is not shown in our chassis illustrations. From this unit emerges a standard 7-pin plug, which fits into a socket on the chassis deck. The sockets are numbered in our plan chassis view, and the pins and sockets are shown by arrows and numbers in circles in the circuit diagram.

Voltage adjustment is carried out by a special 3-pin plug on a 3-way lead emerging from the chassis. These fit into corresponding sockets on the voltage adjustment unit, there being three sockets for each voltage tapping.

Holding the plug so that the two pins close together on the left, the left hand pin is that connected to V8 anode, the next pin is that connected to C37 and L22, and the right hand pin is that connected to L18 and V5 screen. These pins are shown by arrows in the diagram, but are not numbered. They are, however,

lined up to be opposite the rows of sockets into which they are plugged.

It should be noted that certain connections have rather a complicated path in the receiver. For instance, the lower mains input connection goes to one fuse on the resistance unit, then, via pin 3 on the 7-pin plug, into the chassis, through S13 and L22, then out to the 3-pin plug, through part of R29, then into the chassis again via pins 1 and 5 on the 7-pin plug.

**Model 571 on 25 C.S.**—It is possible to use the table model 571 on AC mains down to 25 C/S, but in this case it will be necessary to wire an extra 16 μF electrolytic condenser in parallel with C33, making a total of 32 μF in this position. The part number of the correct additional condenser is 22675F.

This addition may also be found effective in clearing up hum in 571, 572 and 573 models when they are operated on bad 40 C/S mains.

**Earthing Arrangements.**—The chassis (and all the screens returned to chassis) is earthed for RF via C3. A split earth socket is used, one side going to C3 and the other side to socket 4 of the 7-pin connector and to the speaker frame, one side of L19 and various exposed metal parts. Pin 4 of the connector plug goes to the casing of R29. When the earth plug is inserted, therefore, all these parts are directly earthed, and the chassis is earthed via C3.

**Chassis Divergencies.**—C25 is 50 μF in our chassis, not 25 μF. In some models L22 and C37 may be found on the front outside edge of the chassis.

MODELS 572 AND 573 MODIFICATIONS

The radiogram models 572 and 573 have chassis similar to the 571, except that, of course, a pick-up is fitted, and there is a fourth (gram) position of the switch. The same switch units are fitted, and in fact

Switch diagrams, as seen from beneath the chassis, in the directions of the arrows in the under-chassis view. The bearer tags (Be) are wired up, but are only used in the radiogram models (see under Models 572 and 573 Modifications).

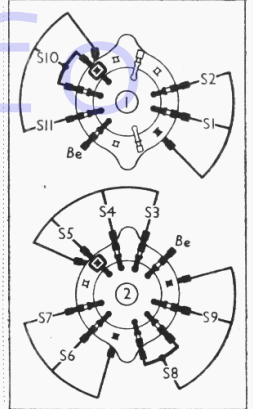

the pick-up wiring not used in the table model is brought into use.

For the extra switches the tags marked Be (bearer) in our switch diagrams are used.

The pick-up is connected across the primary of an input transformer, which also has a 15,000 Ω resistance across its primary. One side of the secondary goes to chassis, and the other side to the Be tag on switch unit 1. The other side of the switch so formed goes to the top of the volume control R10. This switch closes on gram, and is open on all other positions.

The input transformer has a primary resistance of 172 Ω and a secondary of 280 Ω. The pick-up resistance is 850 Ω. The socket for earthing the pick-up screening goes to one side of the primary of the transformer, and to chassis via a 0.005 μF condenser.

The Be tag on switch unit 2 is connected to the HT line, and on gram the switch so formed closes, and connects the anode of V1 direct to the HT line.

The external speaker arrangements differ from those of the table model, and two sockets are provided for a 5 Ω external speaker. Across these sockets is connected a 50 Ω resistance. A switch is fitted, which connects into circuit either the internal or external speakers separately, or both together.

The motor is a series wound commutator type, operating on 35 V input, via an adjustable voltage dropping resistance. Two extra chokes are inserted in the motor feed, for interference suppression, while there are two fixed condensers in series across the brushes, their common connection being earthed.

CIRCUIT ALIGNMENT

**IF Stages.**—Switch set to LW, turn gang to maximum and volume control to maximum. Connect signal generator to grid (top cap) of V2, via a 0.1 μF condenser, leaving existing top cap connection in place, and to chassis. Feed in a 465 KC/S signal and adjust C51, C52, C53 and C54 in that order, for maximum output. Re-check these adjustments.

**RF and Oscillator Stages.**—SW—Connect signal generator to A and E sockets and switch set to SW. Feed in an 18 m (16.7 MC/S) signal, tune it in, and adjust C46 and C38 for maximum output, rocking the gang slightly for optimum results.

Feed in a 50 m (6 MC/S) signal, and tune it in. Then adjust the inductance of L1, L4 and L8 if necessary. A loop of wire will be found running across the coil formers and this loop must be bent up or down until maximum output is obtained. Identify the loop by first removing the coil can; then replace the can and move the loop by a strip of insulating material with a suitable nick in it. This adjustment will not normally be necessary.

Return to 18 m and re-adjust C38 very carefully, while rocking the gang.

**MW.**—Switch set to MW, turn gang to 205 m mark, and feed in a 205 m (1,463 KC/S) signal. Adjust C47 for maximum output. Feed in a 225 m (1,333 KC/S) signal, tune it in, and adjust C39 and C42 for maximum output. Feed in a 530 m (565 KC/S) signal, tune it in, and adjust C48 for maximum output, rocking the gang for optimum results. Return to 205 m, and check setting of C47.

**LW.**—Switch set to LW, turn gang to minimum, and feed in a 725 m (414 KC/S) signal. Adjust C49 for maximum output. Feed in an 850 m (353 KC/S) signal, tune it in, and adjust C40 and C43 for maximum output. Feed in a 1,900 m (158 KC/S) signal, tune it in, and adjust C50 for maximum output, rocking the gang for optimum results. Check setting of C49 at 725 m.

Finally, return to MW, and go through whole of MW and LW alignment again. Set the scale pointer to give best possible calibration compromise.

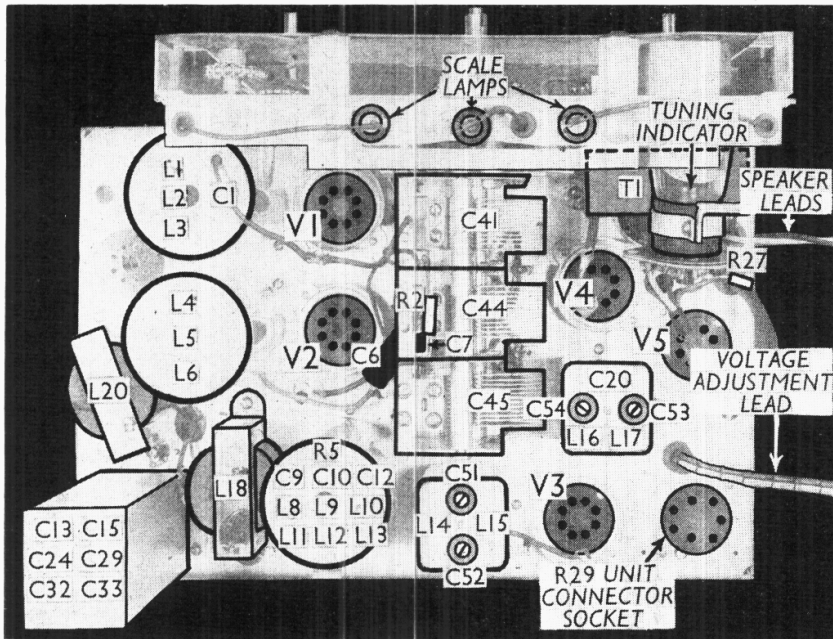

Plan view of the chassis. Note the leads to the 3-pin voltage adjustment plug and the socket which takes the 7-pin plug from the voltage adjustment unit.