

'TRADER' SERVICE SHEET

207

PYE QAC2

3-VALVE A.C. SUPERHET

THREE models of the Pye QAC2 receiver are made, for different mains voltages and periodicities. One is for 200-250 V, 40-100 C/S, another is for 200-250 V, 25-39 C/S, and the third is for 100-150 and 200-250 V, 40-100 C/S. The receiver on which this *Service Sheet* was prepared was of the first type, and had a double diode-output pentode valve in the last stage. Some models are fitted with separate double diode and output pentode valves, but are otherwise identical.

CIRCUIT DESCRIPTION

Aerial input via coupling coil **L1** and small coupling condenser **C1** to inductively coupled band-pass filter. Primary **L2, L3** tuned by **C17**; secondary **L4, L5** tuned by **C19**.

First valve (**V1, Ever Ready metallised A80A**) is an octode operating as a frequency changer with electron coupling. Oscillator grid coils **L6, L7** tuned by **C21** with shaped vanes for tracking; trimming by **C22** (M.W.) and **C23** (L.W.); anode reaction coil **L8**.

Second valve, a variable-mu R.F. pentode (**V2, Ever Ready metallised**

via **C12**, provides D.C. potential which is developed across **R12** and fed back through decoupling circuit as G.B. to F.C. and I.F. valves, giving automatic volume control. Delay voltage is developed across **R10, R11**.

Three-position tone control by **C14, R14, S5, S6**. Provision for low impedance external speaker across secondary of **T1**.

H.T. current is supplied by full-wave rectifier valve (**V4, Ever Ready S11D**). Smoothing by speaker field **L15** and dry electrolytic condensers **C15, C16**.

COMPONENTS AND VALUES

RESISTANCES		Values (ohms)
R1	V1 pentode C.G. decoupling	510,000
R2	V1 S.G. potential divider	25,000
R3	V1 fixed G.B. resistance	40,000
R4	V1 osc. C.G. resistance	150
R5	V2 fixed G.B. resistance	20,000
R6	V2 fixed G.B. resistance	300
R7	I.F. stopper	110,000
R8	V3 signal diode load; vol. control	500,000
R9	V3 pentode C.G. resistance	110,000
R10	A.V.C. delay and V3 G.B. resistances	200
R11	A.V.C. delay and V3 G.B. resistances	500
R12	A.V.C. diode load resistance	1,100,000
R13	A.V.C. line decoupling resistance	1,100,000
R14	Tone control resistance	10,000

CONDENSERS		Values (μF)
C1	Capacitive aerial coupling	0.000005
C2	V1 C.G. condenser	0.0002
C3*	V1 pentode S.G. by-pass	2.0
C4	V1 cathode by-pass	0.1
C5	A.V.C. line decoupling condenser	0.1
C6	V1 osc. C.G. condenser	0.0002
C7	V2 cathode by-pass	0.1
C8	I.F. by-passes	0.0001
C9	I.F. by-passes	0.0001
C10	L.F. coupling to V3 pentode	0.003
C11*	V3 cathode by-pass	20.0
C12	Coupling to V3 A.V.C. diode	0.00001
C13	Fixed tone corrector	0.001
C14	Part of tone control circuit	0.025
C15*	H.T. smoothing	8.0
C16*		8.0
C17†	Band-pass primary tuning	—
C18‡	Band-pass primary trimmer	—
C19†	Band-pass secondary tuning	—
C20†	Band-pass secondary trimmer	—
C21†	Oscillator tuning	—
C22‡	Oscillator main trimmer	—
C23‡	Oscillator L.W. trimmer	—
C24†	1st I.F. trans. pri. tuning	—
C25†	1st I.F. trans. sec. tuning	—
C26†	2nd I.F. trans. pri. tuning	—
C27†	2nd I.F. trans. sec. tuning	—

* Electrolytic. † Variable. ‡ Pre-set.

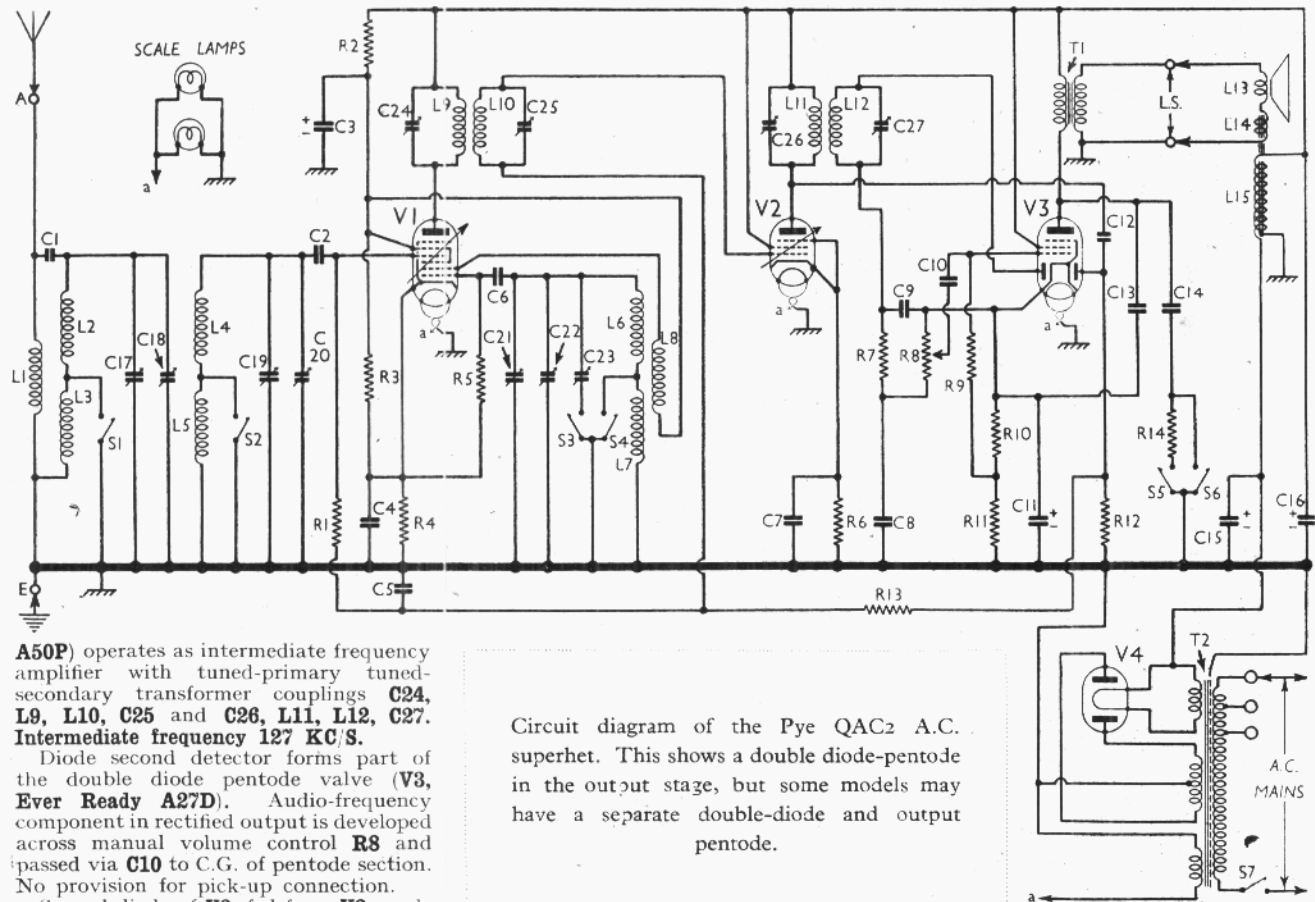

A50P) operates as intermediate frequency amplifier with tuned-primary tuned-secondary transformer couplings **C24, L9, L10, C25** and **C26, L11, L12, C27**. Intermediate frequency **127 KC/S**.

Diode second detector forms part of the double diode pentode valve (**V3, Ever Ready A27D**). Audio-frequency component in rectified output is developed across manual volume control **R8** and passed via **C10** to C.G. of pentode section. No provision for pick-up connection. Second diode of **V3**, fed from **V2** anode

Circuit diagram of the Pye QAC2 A.C. superhet. This shows a double diode-pentode in the output stage, but some models may have a separate double-diode and output pentode.

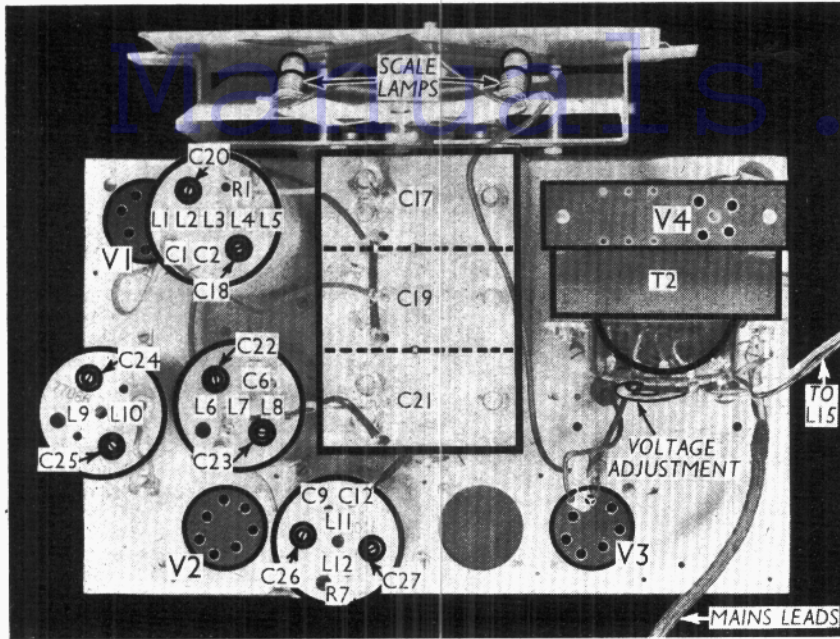

Plan view of the chassis. Most of the coil units contain certain extra components.

electrolytic and black field coil leads to the right-hand terminal, the black electrolytic lead to the screw terminal on the speaker frame, and if the speech coil leads have been unsoldered, connect them to the two left-hand tags.

VALVE ANALYSIS

Valve voltages and currents given in the table below are those measured in our receiver when it was operating on mains of 230 V, using the 216-235 V tapping on the mains transformer. The receiver was tuned to the lowest wavelength on the medium band and the volume control was at maximum, but there was no signal input.

Voltages were measured on the 1,200 V scale of an Avometer, chassis being negative.

Valve	Anode Voltage (V)	Anode Current (mA)	Screen Voltage (V)	Screen Current (mA)
V1 A80A*	240	0.5	60	4.4
V2 A50P	240	9.8	240	3.3
V3 A27D	215	26.0	240	4.5
V4 6X4	315†	—	—	—

* Oscillator anode (G2) 60 V, 2.0 mA
† Each anode, A.C.

GENERAL NOTES

Switches.—S1-S4 are the waveband switches, ganged in a single unit beneath the chassis, and shown in detail in our under-chassis view. S1, S2 and S4 are closed on the M.W. band and open on the L.W. band. S3 is open on the M.W. band and closed on the L.W. band.

S5 and S6 are tone control switches, ganged in a rotary unit, also beneath the chassis, and indicated in our under-chassis view, where the tags are clearly marked. In the fully anti-clockwise position S6 is closed; in the next position S5 is closed, and in the third position both switches are open.

S7 is the Q.M.B. mains switch, ganged with the volume control, R8.

Continued overleaf

OTHER COMPONENTS		Approx. Values (ohms)
L.1	Aerial coupling coil	17.0
L.2	Band-pass primary coils	2.5
L.3		11.5
L.4	Band-pass secondary coils	2.5
L.5		11.5
L.6	Oscillator tuning coils	2.0
L.7		3.5
L.8	Oscillator reaction coil	46.5
L.9	1st I.F. trans.	Pri. 95.0
L.10		Sec. 95.0
L.11	2nd I.F. trans.	Pri. 95.0
L.12		Sec. 95.0
L.13	Speaker speech coil	1.5
L.14	Hum neutralising coil	0.3
L.15	Speaker field coil	2000.0
T1	Speaker input trans.	Pri. 700.0
		Sec. 0.3
	Mains trans.	Pri. (total) 22.2
		Heater sec. 0.08
	trans.	Rect. heat. sec. 0.17
		H.T. sec. (total) 596.0
S1-S4	Waveband switches	—
S5,S6	Tone control switches	—
S7	Mains switch, ganged R8	—

DISMANTLING THE SET

A detachable bottom is fitted to the cabinet and upon removal (four round-head wood screws) gives access to most of the under-chassis components.

Removing Chassis.—If it is necessary to remove the chassis from the cabinet, remove the four control knobs (pull off) and the four screws (with washers) holding the chassis to the bottom of the cabinet. Now free the speaker earthing lead from the cleat on the side of the cabinet and disconnect it by removing the nut holding it to the frame of the mains transformer.

The chassis can now be withdrawn to the extent of the speaker leads, which is sufficient for normal purposes.

To free the chassis entirely, unplug the speaker speech coil leads from the sockets at the rear of the chassis, free the field coil leads from the cleat on one of the speaker fixing screws and disconnect

them from the speaker (two screw terminals). When replacing, connect the red lead to the left-hand terminal and the black lead to the right-hand terminal.

Removing Speaker.—To remove the speaker from the cabinet disconnect the leads and remove the four screws (with spring washers and washers) holding it to the sub-baffle. When replacing, see that the terminal panels are at the bottom and do not forget to replace the cleat for the field coil leads on the bottom right-hand fixing screw. Connect the red field coil and yellow electrolytic leads to the left-hand terminal, the red

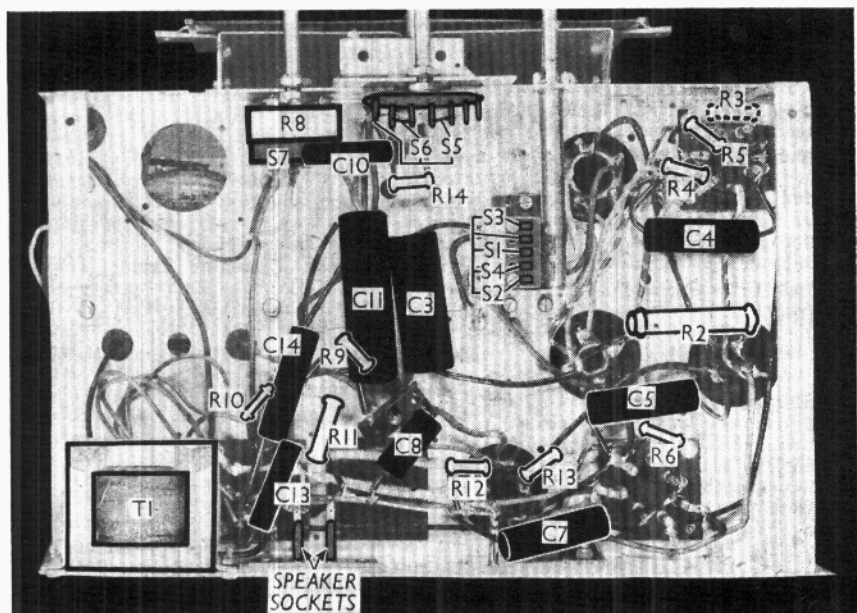

Under-chassis view. All the switches are indicated.

MAINTENANCE PROBLEMS

Dry Joint Causes Tuning Drift

RECENTLY a Murphy A26 was in for service with the complaint that after varying periods of use the "signals" would either disappear or the tuning would drift to an adjacent channel and then go off altogether.

The chassis was removed from the cabinet and placed on test. After an hour it was noticed that the set was not functioning, and after checking back systematically the trouble was located in a dry joint in the AC/TP oscillator anode circuit. When the connecting wire was pulled the receiver functioned again, but by moving the wire about the customer's complaint reasserted itself. Resoldering cured the fault.—H. DIX.

Instability in Murphy A24

SOME Murphy A24 receivers have been in for overhaul, and in a few models instability was noticed when the volume control was at maximum. This trouble was cured in every case by connecting a resistance of a few thousand ohms in the grid lead of the output pentode, in this case an AC/2Pen.—H. DIX, ERITH, KENT.

PYE QAC2—Continued

Coils.—L1-L5, L6-L8, and the I.F. transformers L9, L10 and L11, L12 are in four screened units on the chassis deck. Each unit contains two trimmers, reached through holes in the tops of the cans. Three of the units also contain additional components, indicated in our plan chassis view.

Scale Lamps.—These are two Ever Ready M.E.S. types, rated at 6.2 V, 0.3 A.

External Speaker.—Provision is made at the rear of the chassis for the connection of a low impedance (1.5-2.5 O D.C. resistance) external speaker, either directly to the sockets on the chassis, or to the socketed plugs of the internal speaker.

Condensers C15, C16.—These are two 8 μ F dry electrolytics in a single carton, mounted inside the cabinet, close to the speaker unit. The black lead is the common negative, the yellow the positive of C15 and the red the positive of C16.

Chassis Divergencies.—In some models V3 is replaced by two valves, a separate double diode, and an output pentode (Ever Ready metallised A20B, and A70D). Otherwise, there are no alterations.

V3 Connections.—The base connections of V3 do not conform to the B.V.A. standard. Looking from the ends of the pins, with the usual pin numbering, the connections are: 1, diode anode; 2, cathode; 3, diode anode; 4 and 5, heater; 6, pentode anode; 7, pentode screen; top cap, control grid.

CIRCUIT ALIGNMENT

With the pointer at the higher wavelength end of the scale, push a flat-ended rod through the hole in the chassis

No "Punch" on Gramophone

A H.M.V. 524 was lacking in "punch" on gramophone, but quite O.K. on radio. On checking up it was noticed the makers had included a 230,000 O resistance (R15) in series with the volume control (VR2), and removing this cured all our complaints.—D.W.Y., CORSHAM, WILTS.

Crackling in Ekco B86

A N Ekco B86 gave crackling which was worse on the medium waves than the long, and gradually became worse as the receiver was tuned down the band, until at 200 metres it was quite loud.

This was found to disappear when the connection to the oscillator condenser was removed. A check up on all components in the circuit revealed no fault but it was discovered that the crackling varied in intensity when the oscillator coil can was tapped and careful inspection revealed that the frame of the ganged condenser assembly was earthed *via* this can. A test from can to chassis revealed a resistance of 20 O, which varied when can was tapped.

beneath the gang condenser, until it is against the vanes. Rock the gang until it is felt that the rotor vanes are fully in mesh with the stator. The pointer should now be located centrally with the mark at the higher wavelength end of the scale. If this is not so, a small adjustment may be made by loosening the screw which holds the pointer in position and re-setting the pointer.

I.F. Stages.—Connect a signal generator between control grid (top cap) of V1 and chassis, *via* a 0.002 μ F condenser. The lead to the top cap is removed, and a 0.5 MO resistance is connected between top cap and chassis, while a 0.25 μ F condenser is connected from the oscillator anode pin to chassis.

Feed in a 127 KC/S signal, and adjust C27, C26, C25 and C24 in that order for maximum output. When adjusting a primary winding, connect a 50,000 O resistance across the corresponding secondary, and vice-versa. This is necessary to reduce the effective coupling between the windings.

R.F. and Oscillator Stage.—Tune to 210 m. on the scale, and feed a 210 m. signal into the A and E sockets, with the receiver switched to M.W. Adjust C22 for maximum output. If more than one peak is found, that produced with the least trimmer capacity is correct. Next adjust C20, then C18, for maximum output. Re-check these adjustments at about 520 m. If calibration is 15-20 m. low, C22 is probably tuned to incorrect peak. Re-trim roughly at 520 m., then return to 210 m. and adjust accurately.

Switch set to L.W., tune to 1,000 m. on scale, feed in a 1,000 m. signal and adjust C23 to a point mid-way between two consecutive peaks.

Keep the input low during these adjustments to prevent A.V.C. action.

The nuts holding the can to the chassis were removed and it was seen that the paint had not been scraped off so that there was only a poor connection where the spring washer had partly cut through the paint. When this was thoroughly cleaned off and the nuts tightened, all traces of the crackle vanished.

Since that we have had two of these receivers with the same trouble.—F. R. ELLORY, TYWARDREATH, PAR, CORNWALL.

Intermittent Speech Coil Short

AFTER about one hour's use a 4-valve (plus rectifier) mains superhet gave intermittent trouble, volume falling by about 60 per cent. but quality being still quite good.

Switching the set off, I allowed it to cool down again and connected a signal generator to the aerial input circuit, the grid of the oscillator valve, the I.F. valve and the pick-up sockets and took the output levels across the primary of the speaker transformer, in order to trace the section of the set which was causing the trouble.

I then waited till the set failed again when, to my surprise, output levels were the same but radio was still poor. Since the output meter was connected across the primary, the trouble appeared to be in the speaker, so I disconnected the primary of its transformer and connected an extension speaker. Radio results were now O.K.

Checking the speaker, I found that the resistance of the speech coil was only 0.5 O instead of 2.7 O. The trouble was caused by the poor construction of the speech coil, which had thin paper between the leads from the winding, and the heat from the field coil was causing them to short.—N. C. RAMSDALE, NORTH GOSFORTH, NORTHUMBERLAND.

Set Worked Without Valves!

I HAD a curious experience with a 4-valve battery set operated from a dry H.T. battery and working into a moving-coil speaker, which was mounted on a baffle used as a firescreen. The trouble was that the set continued working at fair volume after it was switched off, and even when the valves, batteries, aerial and earth were removed!

It was found that on the roof of the house was a junction pole carrying wires from the local relay station and somehow their programmes were being picked up.—J. S. W.

Lissen A.F. Transformer Fault

SEVERAL times I have experienced trouble in Lissen sets which I have traced to the centre tap on the A.F. transformer shorting out part of the winding. The secondary connections are brought out to three soldering tags but the centre one is not used. This is found to bear over and make contact with one of the outer tags, thus causing the trouble.—J. S. WATERS, LONDON, S.E.5.