

NUMBER 123

'TRADER' SERVICE SHEETS

BURGOYNE BSH

5-VALVE BATTERY SUPERHET

AN H.F. pentode valve is used for frequency changing in the Burgoyne BSH 5-valve battery-operated superhet, the output stage being of the Class B type. The receiver is housed in a horizontal cabinet with the speaker on the left and the chassis on the right.

CIRCUIT DESCRIPTION

Aerial input via coupling coils **L1**, **L2** and small coupling condenser **C1** to capacity coupled band-pass filter. Primary **L3**, **L4** tuned by **C16**; secondary **L5**, **L6** tuned by **C18**; coupling by **C2** and **C3**. Local-distant switching by **S4**, **S5**, **S6** in conjunction with resistances **R2**, **R3**.

First valve (**V1**, Mullard metallised **SP2**) is an H.F. pentode operating as frequency changer. Oscillator anode coils **L10**, **L11** tuned by **C20**; coupling coils **L8**, **L9** in filament circuit; tracking by shaped condenser vanes and **C6**, **C22** (L.W.).

Second valve, a variable-mu H.F. pentode (**V2**, Mullard metallised **VP2**) operates as intermediate frequency amplifier with tuned-primary tuned-secondary transformer couplings **L12**, **L13** and **L14**, **L15**.

Intermediate frequency 117.5 KC/S.

Volume control is effected by variable potentiometer **R6** which varies G.B. applied to **V2** and simultaneously acts as variable aerial circuit shunt in conjunction with **C4**, **R5** and **L7**.

Triode second detector (**V3**, Mullard metallised **PM1HL**) operates on grid leak system with **C10** and **R8**. Fixed

reaction is applied from anode to second I.F. transformer by coil **L16** and fixed condenser **C11**.

Parallel-fed auto-transformer coupling by **R9**, **C12** and **T1** to triode driver valve (**V4**, Mullard metallised **PM2DL**) which is coupled to positive drive Class B output stage (**V5**, Mullard **PM2B**) by transformer **T2**. Tone correction by fixed condenser **C14**.

COMPONENTS AND VALUES

Condensers		Values (μF)
C1	Capacitive aerial coupling	Very low
C2	Band-pass top coupling	Very low
C3	Band-pass coupling	0.025
C4	Part of volume control circuit	0.0001
C5	V1 C.G. condenser	0.0001
C6	Oscillator L.W. tracker	0.0005
C7	V2 C.G. decoupling	0.1
C8*	Filament circuit by-pass	20.0
C9	V2 S.G. by-pass	0.1
C10	V3 grid condenser	0.00015
C11	Fixed reaction condenser	0.001
C12	L.F. coupling to T1	0.1
C13	V4 grid I.F. by-pass	0.0005
C14	Tone corrector	0.005
C15	H.T. supply reservoir	2.0
C16†	Band-pass primary tuning	—
C17†	Band-pass primary trimmer	—
C18†	Band-pass secondary tuning	—
C19†	Band-pass secondary trimmer	—
C20†	Oscillator tuning	—
C21†	Oscillator trimmer	—
C22†	Oscillator L.W. tracker	—
C23†	1st I.F. trans. pri. tuning	—
C24†	1st I.F. trans. sec. tuning	—
C25†	2nd I.F. trans. pri. tuning	—
C26†	2nd I.F. trans. sec. tuning	—

* Electrolytic. † Variable. ‡ Pre-set.

Resistances		Values (ohms)
R1	B.P. coupling condenser shunt	25,000
R2	Parts of local-distant switching circuit	1,000
R3	V1 C.G. resistance	40,000
R4	Part of volume control circuit	1,000,000
R5	Volume control	10,000
R6	V2 C.G. decoupling	50,000
R7	V3 grid leak	100,000
R8	V3 anode load	1,000,000
R9	V4 grid I.F. stopper	25,000
R10		250,000

Other Components		Approx. Values (ohms)
L1	Aerial coupling coils	1.2
L2		3.0
L3		1.2
L4	Band-pass primary coils	12.6
L5		1.2
L6	Band-pass secondary coils	12.6
L7	Part of volume control circuit	290.0
L8	Oscillator coupling coils	0.3
L9		0.3
L10	Oscillator tuning coils	3.2
L11		12.5
L12	1st I.F. trans. (Pri. Sec.)	120.0
L13		120.0
L14	2nd I.F. trans. (Pri. Sec.)	120.0
L15		120.0
L16	Fixed reaction coil	0.15
L17	Speaker speech coil	2.5
T1	1st intervalve trans. (Pri. Sec.)	1,800.0
		3,900.0
T2	Driver trans. (Pri. Sec. total)	440.0
T3	Speaker input trans. (Pri. Sec.)	240.0
		720.0
Sr-S3	Waveband switches	—
S7		—
S4-S6	Local-distant switches	—
S8	L.T. switch, ganged R6	—
F1	H.T. circuit fuse	—

DISMANTLING THE SET

Removing Chassis.—First remove the back (two knurled head screws) and the batteries. Now remove the three control knobs (recessed grub screws) and the nut from the bush of the wave-change switch. Next remove the four small round-head wood screws holding the back of the chassis to the fillets on the sides of the cabinet, and unsolder the speaker leads.

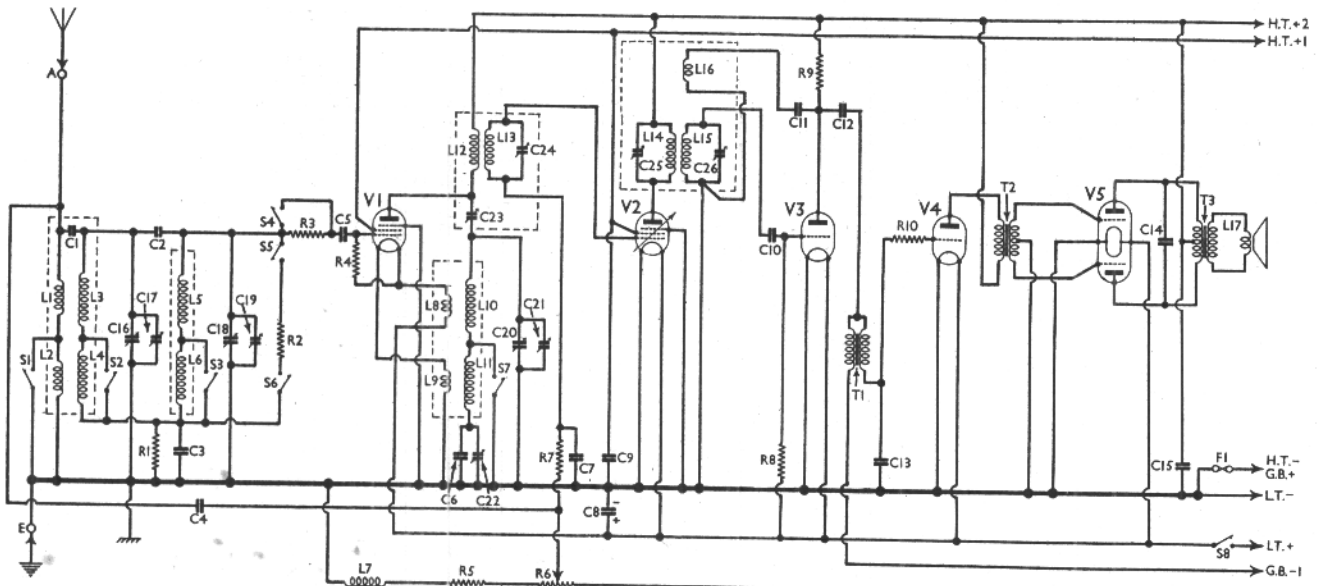

Circuit diagram of the Burgoyne BSH receiver. Note the I.F. reaction coil, L16. C1 and C2 are both very small condensers.

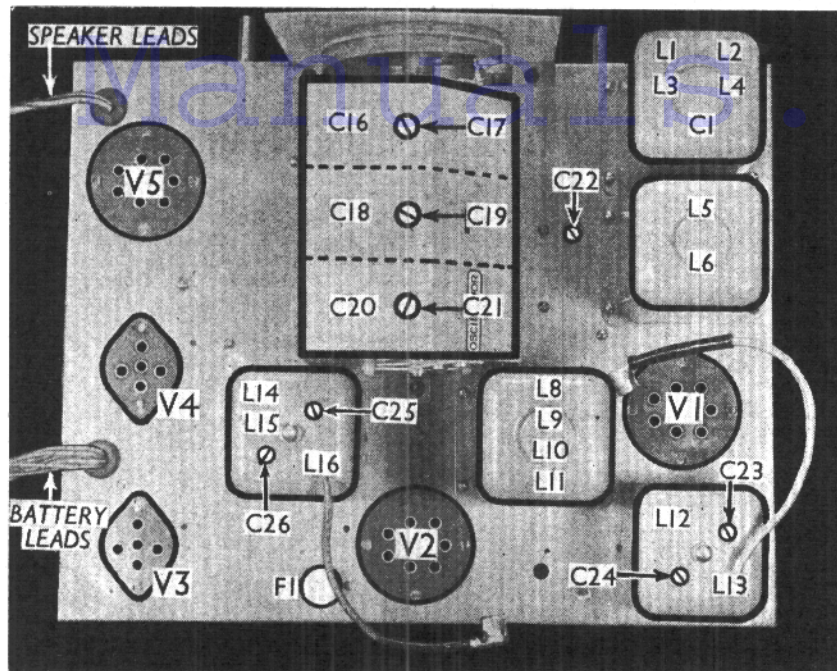

Plan view of the chassis. The L1-L4 unit contains the small condenser C1, while the L14, L15 I.F. unit has an extra reaction winding, L16. F1 screws into a hole in the chassis deck.

The chassis can now be withdrawn from the cabinet and if it is desired to operate it, it will be necessary to extend the speaker leads. In doing so, note that the lead with a knot in it goes to the centre tag on the speaker terminal panel.

Removing Speaker.—To remove the speaker, unsolder the leads and remove the four round-head wood screws holding it to the sub-baffle. *When replacing,* see that the transformer is on the right and note that the lead with a knot in it goes to the centre tag.

VALVE ANALYSIS

Valve voltages and currents given in the table below are those measured in our receiver when it was operating from a new H.T. battery reading 130 V. The H.T.+1 lead was inserted in the 84 V tapping, and the G.B.-1 lead in the 3 V tapping on the G.B. battery.

The volume control was at maximum and the receiver was tuned to the lowest wavelength on the medium band, but there was no signal input.

Voltages were measured on the 1,200 V scale of an Avometer, with chassis as negative.

Valve	Anode Volts	Anode Current (mA)	Screen Volts	Screen Current (mA)
V1 SP2 ..	130	0.7	90	0.2
V2 VP2 ..	130	0.2	90	Very low
V3 PM1HL	72	1.1	—	—
V4 PM2DL	125	3.4	—	—
V5 PM2B	128*	0.5*	—	—

* Each anode.

GENERAL NOTES

Switches.—All the switches are in a single unit beneath the chassis, shown in our under-chassis view. Note that some of the switches in the unit are not used, while some of the tags are common to two switches. The table (col. 2) gives the switch positions for the various control settings, O indicating open, and C, closed.

Switch	Off	M	L	Local
S1	C	C	O	C
S2	O	C	O	C
S3	O	C	O	C
S4	C	O	O	O
S5	C	O	O	C
S6	O	C	O	C
S7	O	C	O	C
S8	O	C	C	C

In the "local" position of the switch, the receiver operates on the M.W. band.

Coils.—These are in five screened units on the chassis deck. The L1-L4 unit also contains C1, which is a small condenser consisting of a single turn of tinned copper wire covered with sleeving.

The second I.F. transformer, L14, L15 also contains an extra winding L16. **Fuse F1.**—This is an M.E.S. type lamp bulb. It is marked "3.5 V."

Batteries.—The batteries supplied are: L.T., Exide celluloid case 2 V 25 AH cell, type LCA3; H.T. and G.B., Drydex yellow triangle combined 120 V H.T. and 9 V G.B., type S48.

Battery Leads and Voltages.—Black spade tag, L.T. negative; Red spade tag, L.T. positive 2 V; Black (unmarked) plug, H.T. negative and G.B. positive; Red H.T.+1 plug, H.T. positive 72-84 V; Red H.T.+2 plug, H.T. positive 120 V; Black G.B.-1 plug, G.B. negative 1.5-3 V; Black G.B.-2 plug, G.B. negative 9 V.

Condenser C2.—This is a very small condenser formed by twisting together the leads from C16 and C18 to their respective coil units.

Condenser C25.—Although this trimmer is included in the first I.F. transformer unit, it is not connected across L12 as usual, but from the bottom of L12 to the top of L10 in the oscillator unit.

CIRCUIT ALIGNMENT

I.F. Stages.—Feed a 117.5 KC/S signal into the grid circuit of V1, and adjust C26, C25, C24 and C23 for maximum output.

H.F. and Oscillator Stages.—Turn tuning condenser until vanes are fully out of mesh, and set pointer exactly vertical. Turn tuning knob until pointer reads 200 m., switch set to M.W., and inject a 200 m. signal into the A. and E. sockets. Adjust C21 for maximum, then C19 and C17.

Switch set to L.W., feed in a 1,700 m. signal, tune set to 1,700 m., and adjust C22 for maximum output.

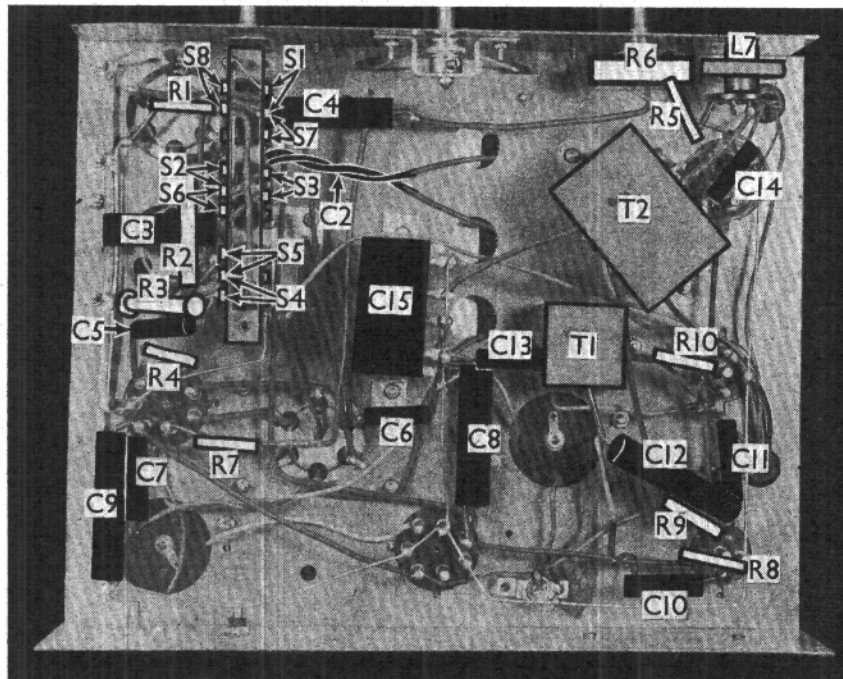

Under-chassis view. Some of the tags on the switch unit are blank, while others are common to two switches. Note the twisted wires forming C2.