

NUMBER 106

'TRADER' SERVICE SHEETS

FERRANTI 'NOVA' AND 'LANCASTRIA' 1935-36 Models

**I**N both their "Nova" and "Lancastria" receivers released in May, 1935, Ferranti incorporate a 3-valve (plus rectifier) A.C. superhet chassis, employing a heptode frequency changer, a variable-mu pentode I.F. amplifier and a double diode output pentode. The chassis has provision for using the mains as an aerial, for a gramophone pick-up and for an extension speaker, a switch enabling the speaker in the receiver to be cut out. The "Nova" model is housed in a moulded cabinet but the "Lancastria" has a walnut cabinet. In addition, the latter embodies a visual tuning indicator

(VHT4) is a heptode operating as frequency changer with electron coupling. Oscillator grid coils **L9, L10** tuned by **C28**; anode reaction coils **L11, L12**; tracking by pre-set condenser **C30** (M.W.) and **C31** (L.W.).  
 Second valve, a variable- $\mu$  H.F. pentode (**V2, Ferranti metallised VPT4**) operates as intermediate frequency amplifier with tuned-primary tuned-secondary transformer couplings **L13, L14** and **L15, L16**.  
**Intermediate frequency 125 KC/S.**  
 Moving-iron tuning indicator meter **T.I.** is connected in common anode

H.T. feed line to **V1** and **V2** (*Lancastria model only*).

Diode second detector forms part of double diode output pentode (**V3, Ferranti PT4D**). Second diode, fed via condenser **C17**, provides D.C. potential which is developed across load resistances **R20, R21** and fed back through decoupling circuits as G.B. to F.C. and I.F. valves, giving automatic volume control. Delay voltage is obtained from drop along **V3** cathode resistances **R17, R18**.

Noise suppression (*Lancastria model only*) by additional resistance **R11** in **V2** cathode circuit which increases fixed G.B. applied when switch **S6** is open; simultaneously switch **S7** connects **V2** C.G. return to **R12**, thus increasing degree of A.V.C. applied.

Audio-frequency output from **V3** signal diode is developed across load resistance **R14** and passed via coupling condenser **C14** and manual volume control **R15** to control grid of pentode section. Provision for connection of gramophone

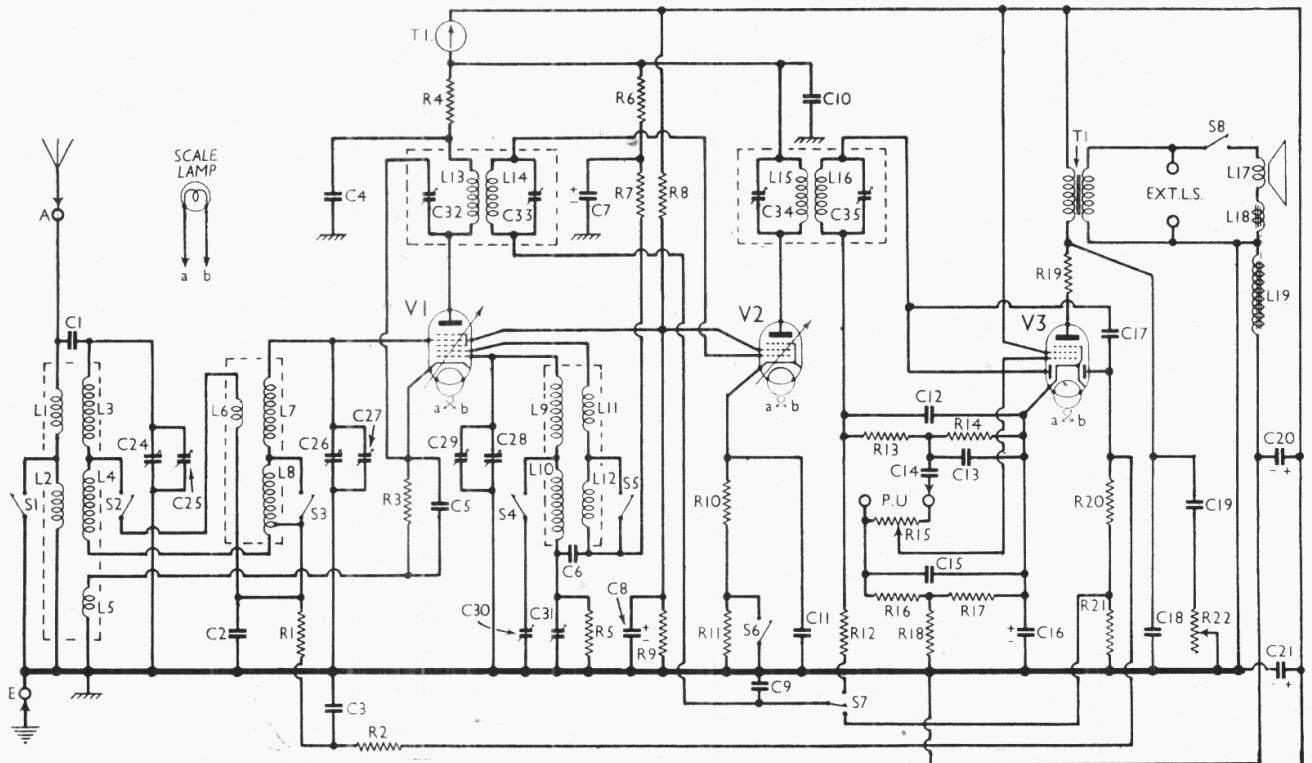

of the meter type and a switch for inter-station noise suppression.

The receiver on which we prepared this *Service Sheet* was a "Nova" model, but notes are included on the differences in the "Lancastria."

**CIRCUIT DESCRIPTION**

Aerial input via coupling coils **L1, L2** and small condenser **C1** to mixed-coupled band-pass filter. Primary **L3, L4**, tuned by **C24**; secondary **L7, L8** tuned by **C26**; coupling by coil **L6** and condenser **C2**. Small coil **L5** is image rejector.

First valve (**V1, Ferranti metallised**

Circuit diagram of the Ferranti Lancastria receiver. The Nova circuit is similar, except that the tuning indicator is omitted, as are **S6, S7, R11** and **R12**. See also paragraph in General Notes.

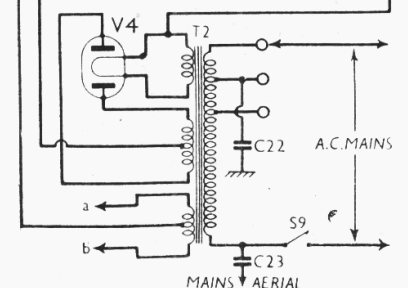

Under-chassis view of the Nova receiver. The additional components R11, R12, S6 and S7 to be found in the Lancastria are shown dotted. A separate diagram of the switch unit appears overleaf.

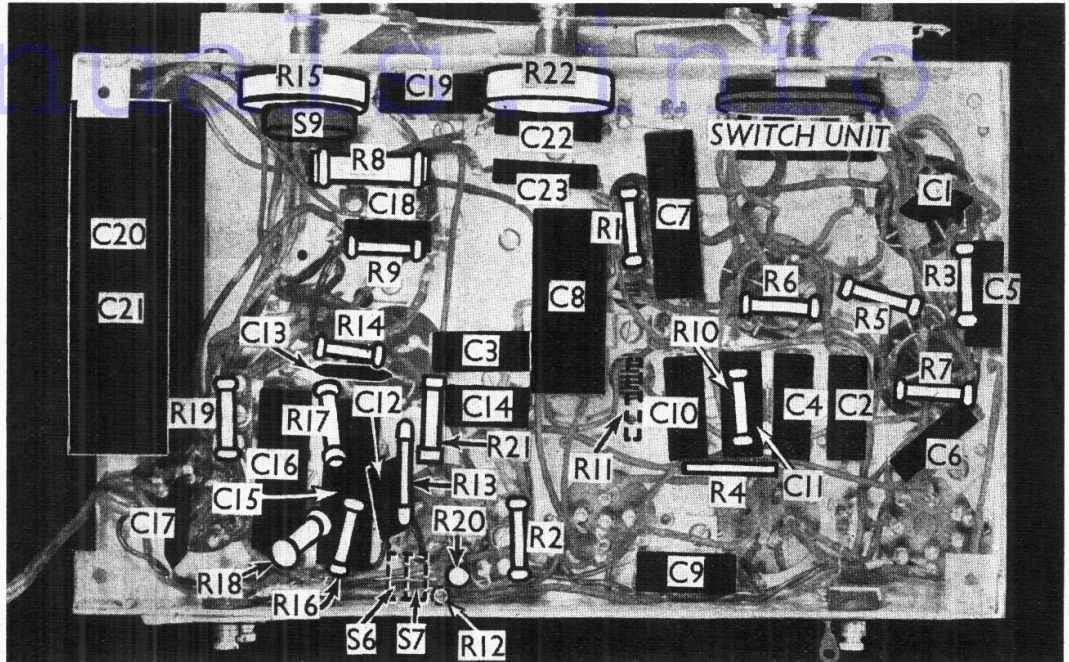

pick-up across volume control. Fixed tone correction in anode circuit by condenser C18; variable tone control by R.C. filter R22, C19. Provision for connection of low-impedance external speaker across secondary of internal speaker transformer T1. Switch S8 breaks internal speaker speech coil circuit.

H.T. current is supplied by full-wave rectifying valve (V4, Ferranti R4). Smoothing by speaker field coil L19 (in H.T. negative line) and dry electrolytic condensers C20, C21. Mains H.F. bypassing by C22. Mains aerial coupling by C23.

**COMPONENTS AND VALUES**

Condensers	Values (µF)
C1	Capacitative aerial coupling .. 0.000016
C2	Band-pass coupling .. 0.05
C3	V1 A.V.C. line decoupling .. 0.05
C4	V1 tetrode anode decoupling .. 0.1
C5	V1 cathode by-pass .. 0.05
C6	V1 oscillator anode decoupling .. 0.01
C7*	V1 oscillator anode decoupling .. 1.0
C8*	V1 and V2 S.G.'s by-pass .. 4.0
C9	V2 C.G. decoupling .. 0.05
C10	V1 and V2 anodes decoupling .. 0.1
C11	V2 cathode by-pass .. 0.1
C12	I.F. by-passes .. 0.00015
C13	I.F. by-passes .. 0.00015
C14	L.F. coupling to vol. control .. 0.02
C15	V3 C.G. decoupling .. 0.25
C16*	V3 cathode by-pass .. 4.0
C17	Coupling to V3 A.V.C. diode .. 0.00015
C18	Fixed tone corrector .. 0.002
C19	Part of tone control filter .. 0.05
C20*	H.T. smoothing .. 8.0
C21*	H.T. smoothing .. 8.0
C22	Mains H.F. by-pass .. 0.002
C23	Mains aerial coupling .. 0.002
C24†	Band-pass primary tuning .. —
C25†	Band-pass primary trimmer .. —
C26†	Band-pass secondary tuning .. —
C27†	Band-pass secondary trimmer .. —
C28†	Oscillator tuning .. —
C29†	Oscillator trimmer .. —
C30†	Oscillator M.W. tracker .. —
C31†	Oscillator L.W. tracker .. —
C32†	1st I.F. trans pri. tuning .. —
C33†	1st I.F. trans sec. tuning .. —
C34†	2nd I.F. trans pri. tuning .. —
C35†	2nd I.F. trans sec. tuning .. —

\* Electrolytic † Variable ‡ Pre-set.

Resistances	Values (ohms)
R1	V1 tetrode C.G. decoupling .. 250,000
R2	V1 A.V.C. line decoupling .. 1,000,000
R3	V1 fixed G.B. resistance .. 300
R4	V1 tetrode anode decoupling .. 1,000
R5	V1 oscillator grid resistance .. 50,000
R6	V1 oscillator anode decoupling .. 50,000
R7	V1 and V2 S.G.'s potential divider .. 25,000
R8	V1 and V2 S.G.'s potential divider .. 25,000
R9	V1 and V2 S.G.'s potential divider .. 25,000
R10	V2 fixed G.B. resistance .. 450
R11*	Noise suppressor resistance .. 2,000
R12*	V2 C.G. decoupling .. 250,000
R13	I.F. stopper .. 100,000
R14	V3 signal diode load .. 500,000
R15	Manual volume control .. 1,000,000
R16	V3 C.G. decoupling .. 100,000
R17	V3 G.B. and A.V.C. delay .. 140
R18	voltage resistances .. 600
R19	V3 anode circuit stabiliser .. 140
R20	V3 A.V.C. diode load .. 4,000,000
R21	V3 A.V.C. diode load .. 1,000,000
R22	Variable tone control .. 50,000

\* In Lancastria model only.

Other Components (Cont.)	Approx. Values (ohms)
T2	Mains trans. (Pri. total .. 40.0 Heater sec. .. 0.05 Rect. fil. sec. .. 0.1 H.T. sec. total .. 650.0)
T.I.*	Tuning indicator meter .. 1,200.0
S1-S5	Waveband switches .. —
S6, S7*	Noise suppressor switches .. —
S8	Internal speaker switch .. —
S9	Mains switch, ganged R15 .. —

\* In Lancastria model only.

**DISMANTLING THE SET**

**Removing Chassis.**—To free the chassis from the cabinet, remove the back (six coin-slot screws), remove the four control knobs (pull off), unplug the speaker leads from the panel on the mains transformer and remove the four bolts (with washers) holding the chassis to the bottom of the cabinet. The chassis can now be withdrawn from the cabinet but as the leads are short it will be necessary to extend them if it is desired to test the chassis under operating conditions.

**When replacing,** connect the speaker leads as follow, numbering the pins on the mains transformer panel from the back of the chassis to the front :—1, blue; 2, green; 3, red; 4, black.

**Removing Speaker ("Nova" Model).**—To remove the speaker from the cabinet, remove the nuts and washers from the four bolts holding the sub-baffle to the front of the cabinet, and to remove the speaker from the sub-baffle, remove the four bolts (with nuts, spring washers and washers) holding it to the baffle. *When replacing the baffle,* do not forget the washers between it and the cabinet,

(Continued overleaf)

Other Components	Approx. Values (ohms)
L1	Aerial coupling coils .. 17.0
L2	Aerial coupling coils .. 68.0
L3	Band-pass primary coils .. 5.0
L4	Band-pass primary coils .. 4.0
L5	Image rejector coil .. 45.0
L6	Band-pass coupling coil .. 0.2
L7	Band-pass coupling coil .. 5.0
L8	Band-pass secondary coils .. 4.0
L9	Oscillator grid tuning coils .. 4.0
L10	Oscillator grid tuning coils .. 25.0
L11	Oscillator anode reaction coils .. 5.5
L12	Oscillator anode reaction coils .. 3.2
L13	1st I.F. trans. (Pri. .. 80.0 Sec. .. 80.0)
L14	1st I.F. trans. (Pri. .. 80.0 Sec. .. 80.0)
L15	2nd I.F. trans. (Pri. .. 80.0 Sec. .. 80.0)
L16	2nd I.F. trans. (Pri. .. 80.0 Sec. .. 80.0)
L17	Speaker speech coil .. 4.0
L18	Hum neutralising coil .. 0.3
L19	Speaker field coil .. 1,600.0
T1	Speaker input trans. (Pri. .. 250.0 Sec. .. 0.3)

**FERRANTI 'NOVA' AND 'LANCASTRIA'—(contd.)**

and see that the speaker transformer is at the top.

\* \* \*

**"Lancastria" Model.**—The speaker is mounted differently in the "Lancastria" model as this has a wood cabinet. The speaker can be removed by removing the nuts from the four bolts holding it to the sub-baffle. Access to these can be gained by opening the dust bag.

**VALVE ANALYSIS**

Valve voltages and currents given in the table below are those measured in our receiver when it was operating on mains of 230 V, using the 230 V tapping on the mains transformer. The volume control was at maximum and the set was tuned to the lowest wavelength on the medium band, but there was no signal input. In the case of the "Lancastria" model the noise suppressor switch should be set so that the receiver is operating at maximum sensitivity.

Voltages were measured on the 1,200 V scale of an Avometer, with chassis as negative.

Valve	Anode Volts	Anode Current (mA)	Screen Volts	Screen Current (mA)
V1 VHT4*	300	1.5	100	5.2
V2 VPT4	305	4.6	100	2.1
V3 PT4D	295	37.0	305	6.6
V4 R4	370†	—	—	—

\* Osc. anode (G2) 105 V, 2.0 mA.  
† Each anode, A.C.

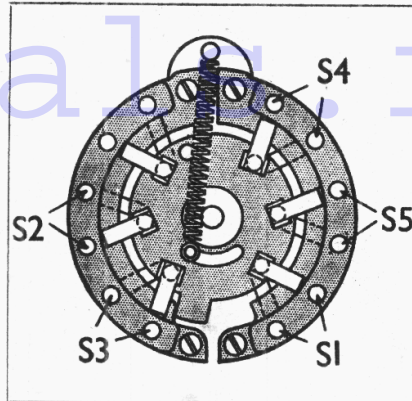

The wavechange switch unit, as seen from the rear. One set of switch contacts is not used.

**GENERAL NOTES**

**Switches.**—S1-S5 are the waveband switches, mounted in a single rotary unit, indicated in the under-chassis view. A separate diagram of this switch unit is given, on which the contacts of the five switches are shown. The diagram is drawn as seen from the rear of the chassis. All the switches are *closed* on the M.W. band and *open* on the L.W. band.

S6 and S7 (*Lancastria* model only) are in a single Q.M.B. unit at the rear of the chassis, shown dotted in our under-chassis view. S8 is the internal speaker switch, of the rotary type, mounted at the rear of the speaker. S9 is the Q.M.B. mains switch, ganged with the volume control R15.

**Coils.**—The coils are in five screened

units mounted on the chassis deck. The oscillator unit contains the trackers C30 and C31, while the two I.F. transformer units contain the trimmers C32, C33 and C34, C35.

**Scale Lamp.**—This is an Ever Ready M.E.S. type, rated at 6.2 V, 0.3 A.

**External Speaker.**—Two terminals are provided at the rear of the internal speaker unit for a low resistance external speaker (about 4 O). Switch S8 (above these terminals) cuts out the internal speaker when desired.

**Pick-up.**—Two terminals are provided for this at the rear of the chassis. There is no pick-up switch. When receiving radio the tag emerging from the chassis close to the upper pick-up terminal should be connected to this terminal, and the pick-up disconnected entirely. When using a pick-up, the set should be detuned, and the tag removed from the terminal.

**Condensers C20, C21.**—These are two 8 μF dry electrolytics in a single unit, with a common positive (red) lead. The black lead to chassis is the negative of C21, and the other black lead the negative of C20.

**Differences between Nova and Lancastria.**—The circuit diagram is that of the Lancastria, and the Nova diagram is similar except that the tuning indicator (T.I.) is omitted, and replaced by a single connecting wire, while S6, S7 and R11, R12 are also omitted. In the Nova the bottom of R10 connects to chassis, while the bottom of L14 connects to the junction of R20 and R21.

Our chassis pictures are of a Nova set, and the components omitted are shown dotted as they would appear in the Lancastria model.

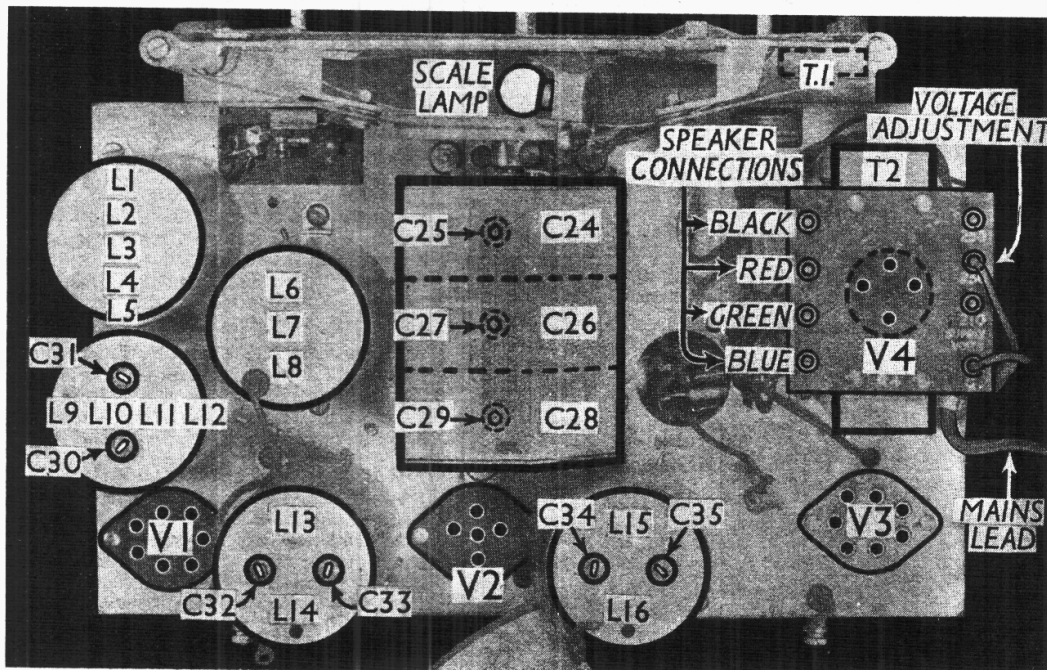

Plan view of the Nova chassis. The Lancastria model is similar, except for the addition of the tuning indicator, shown dotted above. The speaker connections are colour-coded.