

NUMBER NINETY - ONE

'TRADER' SERVICE SHEETS

BUSH AC23

3-VALVE (Plus Rectifier) A.C. RECEIVER

WHILE the standard model of the Bush AC23 3-valve (plus rectifier) A.C. receiver is for mains of 200-250 V, a special model is made for supplies of 100-110 V. A Droitwich filter is fitted and provision is made for a gramophone pick-up and an extension speaker, a plug and socket device enabling the internal speaker to be cut out.

CIRCUIT DESCRIPTION

Two alternative aerial connections (A2 to Droitwich retractor L1, C13) via series resistance R1 and input control potentiometer (volume control) R2 to coupling coils L2, L3. Single tuned circuit L4, L5, C14 precedes pentode H.F. amplifier (V1, Mullard metallised VP4), a variable-mu type operating with fixed G.B.

Tuned-anode coupling by L8, L9, C17 to triode detector (V2, Mullard metallised 354V) operating on grid leak system with C4 and R8. Reaction is applied from anode by coils L6, L7 and controlled by variable condenser C16. Provision for connection of gramophone pick-up in grid circuit. H.F. filtering in anode circuit by stopper resistance R11 and by-passes C6, C7.

Resistance-capacity coupling by R10, C8 and R12 to output pentode (V3, Mullard Pen4VB). Tone correction in anode circuit by fixed condenser C10. Provision for connection of high-impedance external speaker across primary of internal speaker transformer T1. Plug and socket device enables speech coil circuit of internal speaker to be broken.

H.T. current is supplied by I.H.C. full-wave rectifying valve (V4 Mullard IW3). Smoothing by speaker field coil L12 and dry electrolytic condensers C11, C12.

DISMANTLING THE SET

Removing Chassis.—Should it prove necessary to remove the chassis from the cabinet, remove the back (four screws), the four control knobs and the four chassis fixing bolts (with washers). Free the speaker leads from the cleats on the right-hand side of the cabinet, when the chassis can be withdrawn. There is sufficient slack on the speaker leads to

enable normal repairs to be carried out.

To remove the chassis entirely, unsolder the leads on the speaker terminal panel. When replacing, connect the leads as follow, the tags being numbered on the panel:—F and I joined together, red; 2, black; 3, brown; 4, yellow; F, blue.

Removing Speaker.—To remove the speaker, unsolder the connecting leads and remove the nuts and washers from the four bolts with ornamental heads holding the speaker to the front of the cabinet. When replacing, see that the transformer is on the right.

COMPONENTS AND VALUES

Resistances		Values (ohms)
R1	Aerial series resistance	5,000
R2	Aerial input control (volume)	75,000
R3	V1 cont. grid circuit stabiliser	250
R4	V1 S.G. H.T. feed	100,000
R5	V1 G.B. resistance	250
R6	V1 anode decoupling	30,000
R7	Gram. pick-up series resistance	1,000,000
R8	V2 grid leak	1,000,000
R9	V2 anode decoupling	50,000
R10	V2 anode load	50,000
R11	V2 anode H.F. stopper	20,000
R12	V3 grid resistance	500,000
R13	V3 grid H.F. stopper	100,000
R14	V3 G.B. resistance	180

Condensers		Values (μF)
C1	V1 S.G. by-pass	0.1
C2	V1 cathode by-pass	0.1
C3	V1 anode decoupling	0.5
C4	V2 grid condenser	0.0001
C5	V2 anode decoupling	0.5
C6	V2 anode H.F. by-passes	0.0003
C7		0.002
C8	L.F. coupling to V3	0.01
C9*	V3 cathode by-pass	25.0
C10	Tone corrector	0.005
C11*	H.T. smoothing	8.0
C12*		8.0
C13†	Droitwich retractor tuning	0.0003
C14†	Aerial circuit tuning	—
C15†	Aerial circuit trimmer	—
C16†	Reaction control	0.0003
C17†	V1 anode circuit tuning	—
C18†	V1 anode circuit trimmer	—

* Electrolytic † Variable ‡ Pre-set.

Other Components		Approx. Values (ohms)	
L1	Droitwich retractor coil	15.0	
L2	Aerial coupling coils	1.5	
L3		6.4	
L4		3.5	
L5	Aerial tuning coils	14.5	
L6		—	
L7	Reaction coils, total	2.7	
L8		—	
L9	V1 anode tuning coils	3.5	
L10		14.5	
L11	Speaker speech coil	1.8	
L12	Hum neutralising coil	0.1	
	Speaker field coil	2,000.0	
T1	Speaker input trans.	500.0	
		Pri. Sec.	0.25
		25.0	
T2	Mains trans.	8.05	
		Heater sec.	0.1
		Rect. heat. sec.	0.1
		H.T. sec. total	600.0
S1-S3	Waveband switches	—	
S4	Mains switch, ganged R2	—	

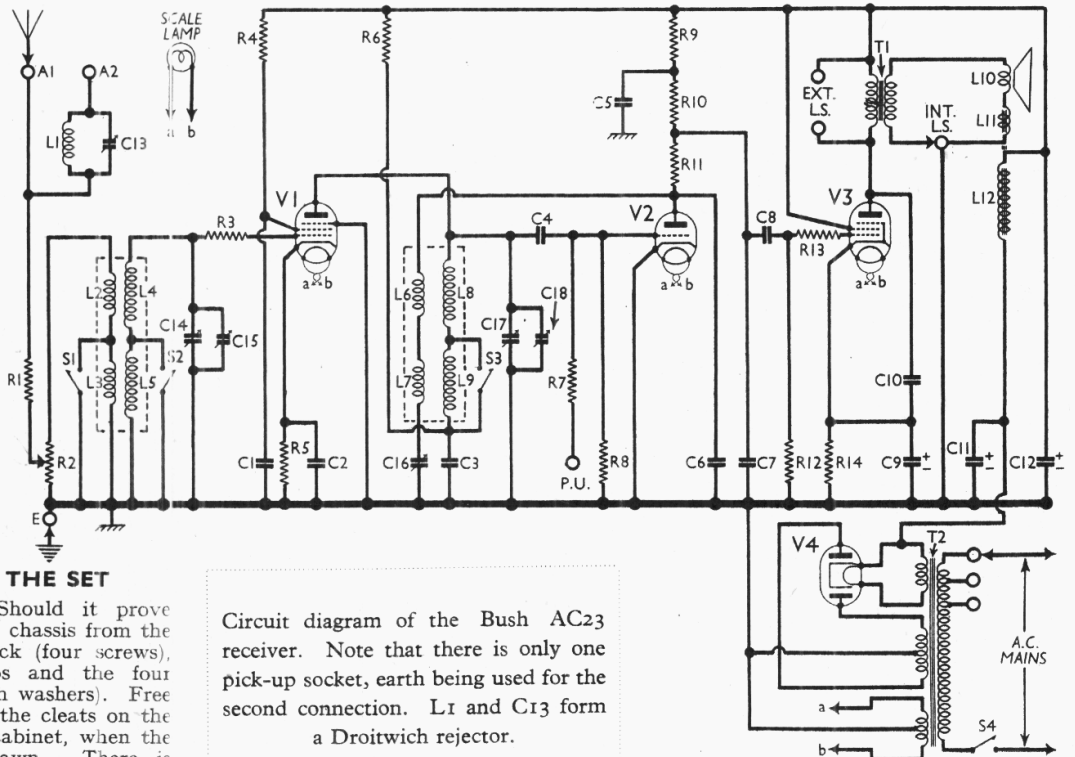

Circuit diagram of the Bush AC23 receiver. Note that there is only one pick-up socket, earth being used for the second connection. L1 and C13 form a Droitwich retractor.

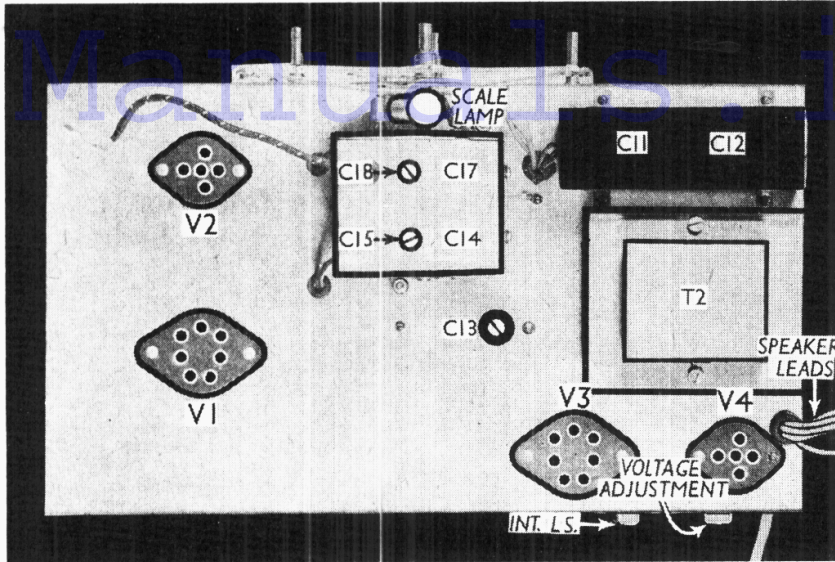

Plan view of the chassis. C13 adjusts the Droitwich retractor circuit. The "Int. L.S." plug cuts out the internal speaker when necessary.

VALVE ANALYSIS

Valve voltages and currents given in the table below were measured with the receiver operating on mains of 220 V, using the 220 V tapping. The volume control was at maximum and the reaction control was at minimum, but there was no signal input.

Voltages were measured on the 1,200 V scale of an Avometer, with chassis as negative.

Valve	Anode Volts	Anode Current (mA)	Screen Volts	Screen Current (mA)
V1 VP4	150	4.2	80	2.1
V2 354V	60	1.9	—	—
V3 Pen4VB	275	34.0	300	4.1
V4 IW3	330†	—	—	—

† Each anode, A.C.

GENERAL NOTES

Switches.—The waveband switches, S1-S3, are ganged in a single unit beneath the chassis, and are all *closed* on the M.W. band, and *open* on the L.W. band.

S4 is the Q.M.B. mains switch, ganged with the volume control R2.

Coils.—L1, the Droitwich retractor coil, is unscreened, and is beneath the chassis. The remaining coils are in two screened units mounted horizontally, also beneath the chassis. Note that the second of these also contains the fixed condenser C4.

The screens are held in position by "bayonet" catches, and can be removed fairly easily.

External Speaker.—There is provision for connecting a high resistance external speaker across the primary of T1, two sockets being fitted at the rear of the chassis.

'RADIO MAINTENANCE' REPRINTS

Reprints of the weekly Radio Maintenance feature, together with a special clip-back binder, are available to "Trader" subscribers only.

The half-yearly subscription to 26 issues of Radio Maintenance (including the Service Sheets and weekly service features) as issued, with one clip-back binder, is 10s. 6d., post free.

Annual subscription to 52 reprints and 2 binders.....£1 ls., post free.

Internal L.S. Switching.—A plug and socket at the rear of the chassis disconnects the internal speaker when required, removal of the plug breaking the secondary circuit of T1.

Pick-up Connection.—A single socket marked "Gram.," is provided at the rear of the chassis, to which one lead from a pick-up may be connected. The other lead must be taken to the earth socket or to the chassis.

Scale Lamp.—This is an Osram M.E.S. type, rated at 6.2 V, 0.3 A.

Trimmer C13.—The Droitwich retractor circuit is tuned by C13, which may be adjusted either above or beneath the chassis.

Resistances R1, R3.—These are encased in rubber sleeving for insulation purposes.

Condensers C11, C12.—These are two 8 μF dry electrolytics in a single unit with a common negative (black) lead. The red lead to the tag leading to one of the V4 filament sockets is the positive of C11, while the remaining red lead is the positive of C12.

Condenser C10.—This is returned to the cathode of V3 and not to chassis, as shown in the makers' diagram.

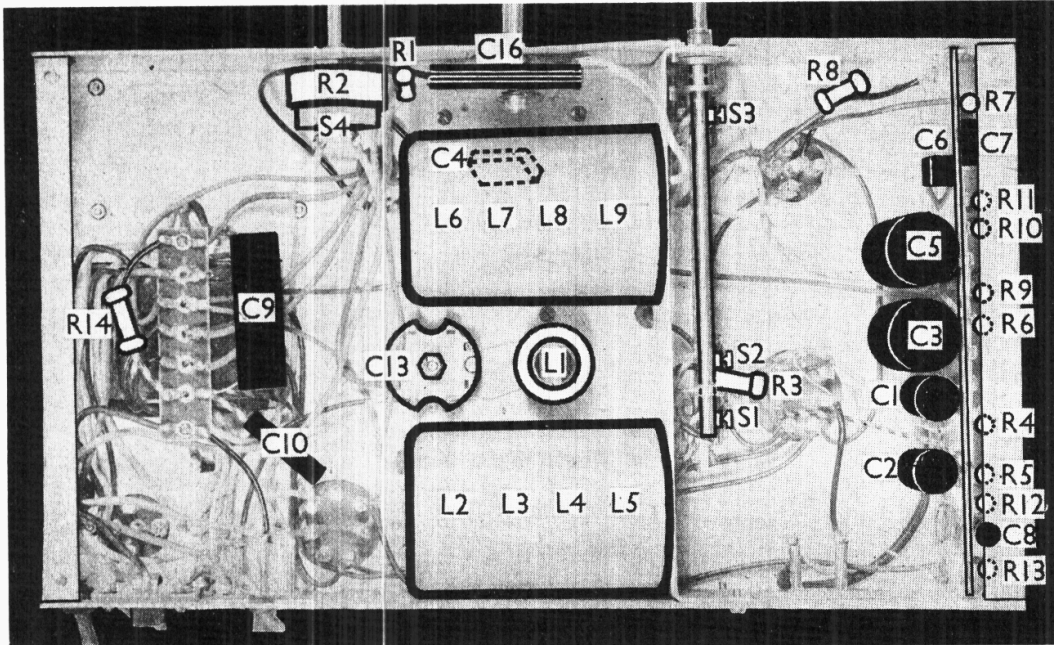

Under-chassis view. C4 is inside the L6-L9 coil unit. The simple wavechange switch unit is clearly indicated.