

NUMBER FIFTY - EIGHT

TRADER SERVICE SHEETS

ALBA MODEL 880

'ALL-WAVE' A.C. SUPERHET

THE Alba Model 880 is an "all-wave" A.C. table superhet employing five valves (plus valve rectifier). Models 890 and 990 are the corresponding console and radiogram versions. The wavelength ranges are approximately 18-50 m., 200-550 m. and 900-2,000 m. They are indicated by a 3-armed pointer, one arm being used for each scale.

CIRCUIT DESCRIPTION

Aerial input on M.W. and L.W. via switch **S1** and coupling coils **L1**, **L2** to inductively coupled band-pass filter. Primary **L3**, **L4** tuned by **C29**; secondary **L7**, **L8** tuned by **C31**; coupling coils **L5** and **L6**. On short-wave band aerial input is via switch **S2**, fixed series condenser **C1**, and coupling coil **L9** to single tuned circuit **L10**, **C31**.

First valve (**V1**, Mullard metallised **FC4**) is an octode operating as frequency-changer with electron coupling. Oscillator grid tuning coils **L13**, **L14** (M.W. and L.W.) and **L11** (S.W.) tuned by **C33**; anode coils **L15**, **L16** (M.W. and L.W.) and **L12** (S.W.); tracking by **C10**, **C36** (L.W.) and **C11** (M.W.). Trimming on S.W. is effected by **C34**, on M.W. by **C35**, and on L.W. by fixed condenser **C9**.

Two variable-mu pentode intermediate frequency amplifiers (**V2** and **V3**, Mullard metallised **VP4B**'s) operating with tuned-primary tuned-secondary iron-cored transformer couplings **L17**, **L18**; **L19**, **L20**; and **L21**, **L22**.

Intermediate frequency 117.5 KC/S.

Moving-iron meter visual tuning indicator in anode feed circuit to **V3**.

Diode second detector forms part of double diode valve (**V4**, Mullard metallised **2D4A**). Second diode, coupled by **C21**, provides D.C. potential which is developed across load resistances **R17**, **R18**, **R19**, and fed back in part through decoupling circuits as G.B. to F.C. and both I.F. valves, giving automatic volume control. Delay voltage obtained from drop along **R22** in **V5** cathode circuit.

Audio frequency component in output from rectifier is developed across load resistance **R15** and passed by way of I.F. stopper **R16**, switch **S18**, coupling condenser **C22**, manual volume control **R20**, and second I.F. stopper **R21** to grid of output pentode (**V5**, Mullard Pen **4VB**). Tone compensation in anode circuit by fixed condenser **C24**. Provision for connection of high resistance external speaker; switch **S20** cuts out internal speaker.

With a gramophone pick-up in use, **V3** operates as L.F. amplifier and is R.C. coupled by **R14**, **C22** and **R20** to **V5**, switch **S17** being closed.

H.T. current is supplied by full-wave rectifying valve (**V6**, Mullard **1W3**). Smoothing by speaker field winding **L25** and electrolytic condensers **C25**, **C26**. Mains disturbance by-passing by **C28**, and mains aerial coupling by **C27**.

DISMANTLING THE SET

Removing Chassis.—Remove back and the four control knobs on front (recessed

grub screws). Remove four bolts (each with one steel and two rubber washers) passing through cabinet bottom. When replacing, do not forget rubber washers between chassis and cabinet bottom. Also note that those that are cut away go underneath the cabinet.

There is enough slack on speaker leads for chassis to be withdrawn sufficiently for normal repairs.

To free chassis entirely, unsolder leads on speaker terminal panel. Panel is numbered and the code is:—F, blue; 1, black; 4, white; F, red. The yellow lead is secured between the transformer casing and speaker frame (not soldered).

Removing Speaker.—Speaker can be removed by removing the four bolts with ornamental heads, holding the sub-baffle to front of cabinet.

COMPONENTS AND VALUES

Resistances		Values (ohms)
R1	V1 pent. cont. grid decoupling	100,000
R2	V1 A.V.C. line decoupling	100,000
R3		1,000,000
R4	V1 S.G.'s pot. divider	25,000
R5		50,000
R6	V1 fixed G.B. resistance	250
R7	V1 osc. grid resistance	50,000
R8	V1 osc. anode decoupling	75,000
R9	V2 cont. grid decoupling	500,000
R10	V2 fixed G.B. resistance	400
R11	V2 and V3 A.V.C. line decoupling	500,000
R12	V3 fixed G.B. resistance	250
R13	V3 S.G. H.T. feed	20,000*
R14	V3 anode decoupling (radio)	5,000
R15	V4 rect. diode load	1,000,000
R16	I.F. stopper	50,000
R17	V4 A.V.C. diode load	500,000
R18		250,000
R19	Manual volume control	500,000
R20		250,000
R21	V5 grid I.F. stopper	100,000
R22	V5 auto G.B. resistance	150

* May be 10,000 O.

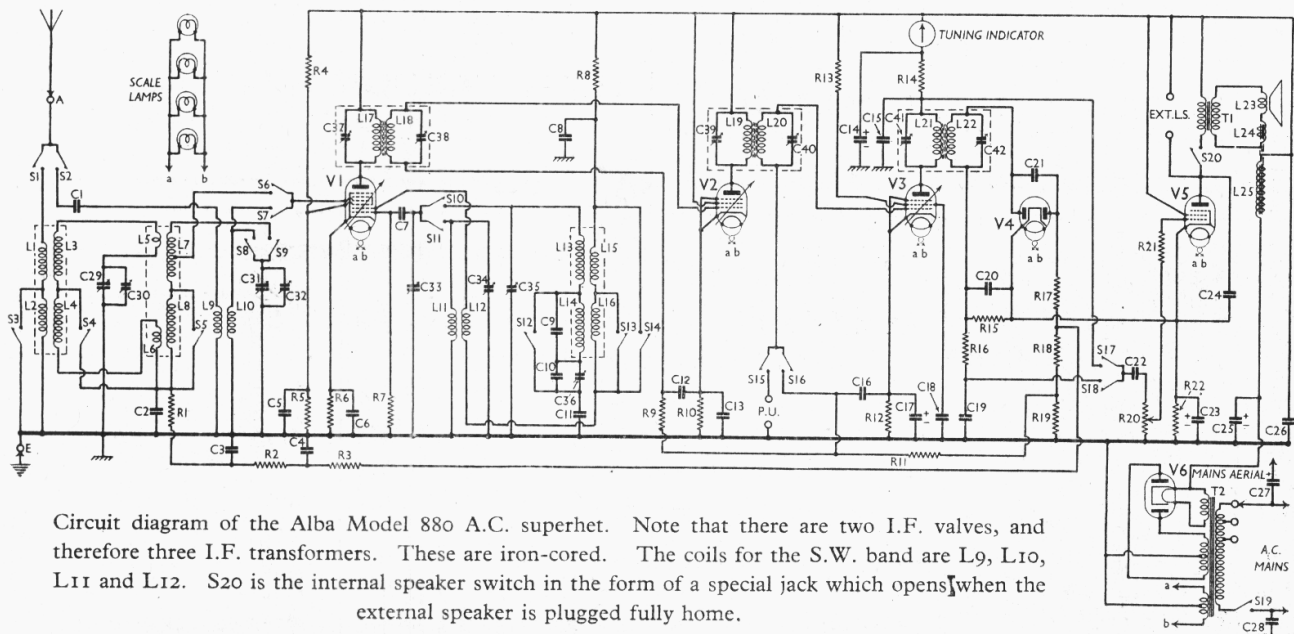

Circuit diagram of the Alba Model 880 A.C. superhet. Note that there are two I.F. valves, and therefore three I.F. transformers. These are iron-cored. The coils for the S.W. band are L9, L10, L11 and L12. S20 is the internal speaker switch in the form of a special jack which opens when the external speaker is plugged fully home.

Condensers		Values (μF)
C1	S.W. aerial coupling condenser	0.000075
C2	V1 pent. cont. grid decoupling	0.1
C3	V1 A.V.C. line decoupling	0.1
C4		0.1
C5†	V1 S.G.'s by-pass	0.1
C6†	V1 cathode by-pass	0.1
C7	V1 osc. grid condenser	0.000025
C8†	V1 osc. anode decoupling	0.1
C9	V1 osc. L.W. trimmer	0.000025
C10	V1 osc. L.W. tracker, fixed	0.0007
C11	V1 osc. M.W. tracker	0.0032
C12	V2 cont. grid decoupling	0.02
C13†	V2 cathode by-pass	0.1
C14†	V3 anode decoupling	2.0
C15	V3 anode by-pass on gram.	0.002
C16	V3 cont. grid decoupling	0.02
C17*	V3 cathode by-pass	25.0
C18	V3 S.G. by-pass	0.1
C19	L.F. by-passes	0.0001
C20		0.0002
C21	Coupling to V4 A.V.C. diode	0.0002
C22	L.F. coupling to V5	0.005
C23*	V5 cathode by-pass	25.0
C24	V5 anode tone compensator	0.005
C25*	H.T. smoothing	8.0
C26*		12.0
C27	Mains aerial condenser	0.0001
C28	Mains H.F. by-pass	0.01
C29	Band-pass primary tuning	—
C30†	Band-pass primary trimmer	—
C31	Band-pass secondary tuning	—
C32†	Band-pass secondary trimmer	—
C33	Oscillator tuning	—
C34†	Oscillator S.W. trimmer	—
C35†	Oscillator M.W. trimmer	—
C36†	Oscillator L.W. tracker	0.0003
C37†	1st I.F. trans. pri. tuning	—
C38†	1st I.F. trans. sec. tuning	—
C39†	2nd I.F. trans. pri. tuning	—
C40†	2nd I.F. trans. sec. tuning	—
C41†	3rd I.F. trans. pri. tuning	—
C42†	3rd I.F. trans. sec. tuning	—

Other Components		Values (ohms)
L1	Aerials coupling coils (M.W. and L.W.)	9.0
L2		100.0
L3	Band-pass primary coils (M.W. and L.W.)	3.5
L4		12.0
L5	Band-pass M.W. coupling coil	0.1
L6	Band-pass L.W. coupling coil	1.75
L7	Band-pass secondary coils (M.W. and L.W.)	3.5
L8		12.0
L9	S.W. aerial coupling coil	0.1
L10	S.W. aerial tuning coil	Very low
L11	S.W. osc. grid tuning coil	Very low
L12	S.W. osc. anode coil	25.0
L13	M.W. and L.W. osc. grid tuning coils	4.5
L14	—	6.5
L15	M.W. and L.W. osc. anode coils	200.0
L16		300.0
L17	1st I.F. trans.	Pri. 50.0
L18		Sec. 50.0
L19	2nd I.F. trans.	Pri. 50.0
L20		Sec. 50.0
L21	3rd I.F. trans.	Pri. 50.0
L22		Sec. 50.0
L23	Speaker speech coil	2.0
L24	Hum neutralising coil	0.1
L25	Speaker field winding	2000.0
T1	Speaker input trans.	Pri. 350.0
		Sec. 0.25
	T2 Mains trans.	Pri. total 50.0
		Heater sec. 0.05
	Rect. heat. sec. 0.1	
	H.T. sec. 600.0	
S1-S14	Waveband switches	—
S15	Radio-gram. switches	—
S16		—
S17	Mains switch, ganged R20	—
S18		—
S20†	Internal speaker switch	—

Valve	Anode Volts	Anode Current (mA)	Screen Volts	Screen Current (mA)
V1 FC4*	240	2.0	86	4.9
V2 VP4B	240	9.5	240	3.1
V3 VP4B	168	8.0	176	2.8
V4 2D4A	—	—	—	—
V5 Pen4VB	228	32.0	240	3.6
V6 IW3	350†	—	—	—

* Osc. anode (G2) 7.4V, 2.1 mA.
† Each anode, A.C.

GENERAL NOTES

Switches.—There are twenty switches in all, of which **S1-S18** are ganged in the main assembly seen in the under-chassis view. This assembly has four positions, S.W., M.W., L.W. and Gram., and the table below shows all the switch positions. O indicates open, and C, closed.

Switch	S.W.	M.W.	L.W.	Gram.
S1	O	C	C	O
S2	C	O	O	C
S3	O	C	O	C
S4	O	C	O	O
S5	C	C	O	O
S6	O	C	C	C
S7	C	O	O	O
S8	C	O	O	O
S9	O	C	C	C
S10	O	C	C	C
S11	C	O	O	O
S12	O	C	O	O
S13	O	C	O	O
S14	C	O	O	C
S15	O	O	O	C
S16	O	C	O	C
S17	O	C	O	C
S18	C	C	C	O

(Continued overleaf)

VALVE ANALYSIS

Valve voltages and currents in the table below are those given by A. J. Balcombe, Ltd. Voltages were measured with a high resistance meter.

* Electrolytic. † May be 0.15 μF . ‡ Pre-set condenser.

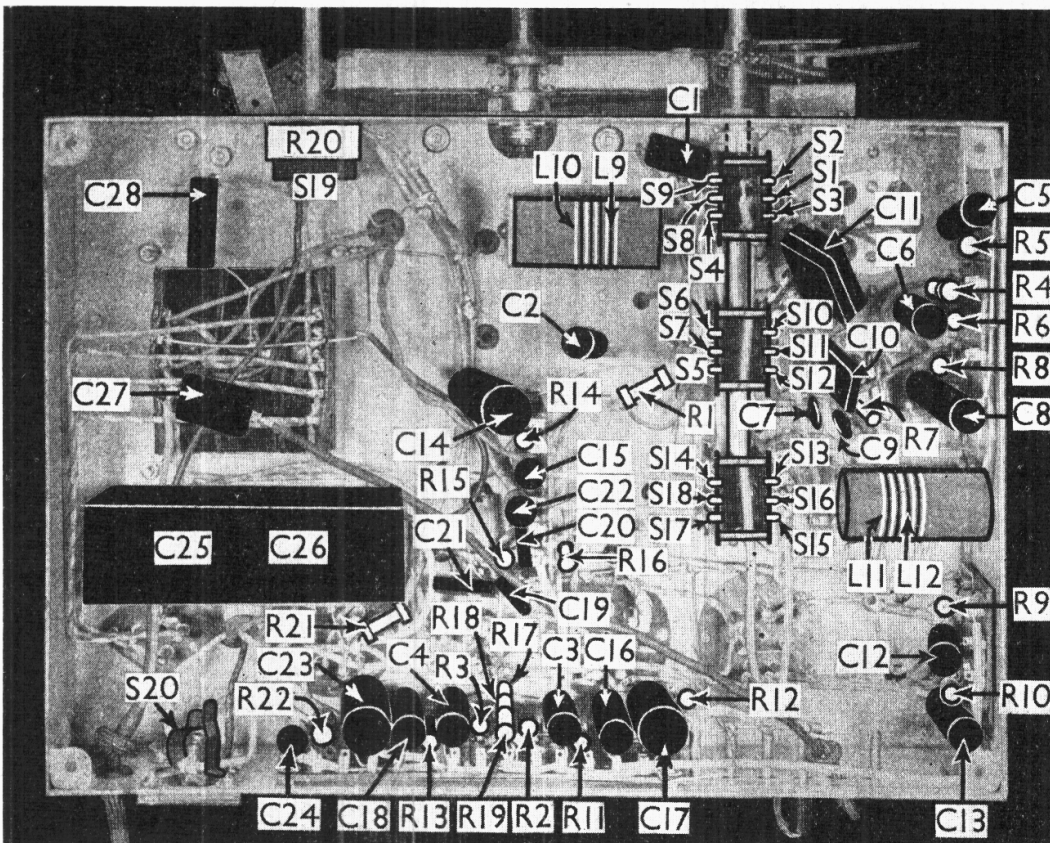

Under-chassis view. All the switches are clearly indicated. C7 and C9 are special small fixed condensers. C11 consists of two condensers in parallel. In the S.W. coil units, the coils shown in white are the grid (tinned copper wire) windings.

ALBA MODEL 880 (contd.)

S19 is the mains switch, ganged with the volume control **R20**, while **S20** is the internal speaker switch at the rear of the chassis, which opens when an external speaker is plugged in.

Coils.—All the M.W. and L.W. signal frequency coils, and the three I.F. transformers, are in screened units on top of the chassis. In our plan chassis view the screens of the signal frequency units have been removed, and the individual coils are indicated. Note that in the first unit **L1** is inside the former near its base. Some of the coils, notably **L15** and **L16**, are wound with resistance wire, and therefore have relatively high resistances.

The S.W. units are on tubular formers beneath the chassis, and are not screened. The bare tinned copper windings are the grid coils in each case.

Scale Lamps.—There are four of these in all, and they are connected in parallel. Osram M.E.S. types, rated at 6.2 V, 0.3 A are used.

Condensers C25, C26.—These are two dry electrolytics in one unit, with a common negative (black) lead. **C25** has a red positive lead, and **C26** a yellow positive.

Condenser C11.—This consists of two fixed mica condensers in parallel to make up the required capacity.

Condensers C5, C6, C8, C13.—These are rated at 0.1 μ F each, but may be 0.15 μ F in some chassis.

Condenser C20.—This is 0.0002 μ F, but may be 0.00025 μ F in some chassis.

Tuning Indicator.—The resistance of the winding of this is 3,300 Ω .

Valves V2 and V3.—Note that in the case of these H.F. pentodes, the connections are different from the usual ones. The top cap connection is the control grid, while the anode is taken to pin 2. These two electrodes are thus interchanged in comparison with more normal types, which have the anode taken to the top cap and the grid to pin 2. The other connections are the same in each case.

CIRCUIT ALIGNMENT

In this receiver the oscillator circuits have separate pre-set trimmers for the S.W. and M.W. ranges (**C34** and **C35**), and a fixed condenser (**C9**) for the L.W. range. The trimmer **C32** is adjusted for M.W. band, and is across the grid coil on the S.W. band. Owing to the tuning of this circuit being fairly flat on the S.W. band, no further adjustment is made, trimming being carried out on this band by **C34** only.

The I.F. transformers are lined up at the works on an oscilloscope, and unless it is absolutely necessary, they should not be touched. Should occasion arise when re-alignment is desirable, it is recommended that the receiver should, if possible, be returned to the makers for attention.

HINTS & PROBLEMS

(Concluded from page IV)

it does come out, it should be replaced with its convex side towards the centre of the knob. We notice that in some knobs the spring is held in place with Plasticene, but even this does not guarantee that it will not fall out.

When replacing knobs, do not push them on so far that they rub on the cabinet front, thus scratching it, and also making the controls hard to turn.

Automatic G.B. Fault

A faulty output valve G.B. resistor produced curious results in a receiver recently. The symptoms of the trouble were loss of output volume and rather bad distortion. A broken (open circuited) bias resistor was suspected, but an anode current measurement on the output valve showed that a small current was passing. With a complete break in the bias resistor, one would expect a zero anode current, since the circuit from cathode, via the bias resistor to chassis would be open.

A check on the value of the bias resistor showed this to be very high, but since the component was of the wire-wound type, this was felt to be rather curious. An examination of the circuit diagram revealed that there was an electrolytic condenser across the resistor. Disconnecting this, it was found that

the bias resistor had, in fact, broken down, and therefore the electrolytic condenser across it was acting as a very high value bias resistance. It will be appreciated that an electrolytic condenser will always pass a small D.C., differing in this respect from a paper type. Had the by-pass condenser been of the latter type, the cathode circuit would have been open-circuited when the bias resistor failed, and the output valve anode current would have fallen to zero.

Faulty Condenser Blocks

In cases where one condenser in a block of two or more is found to be faulty, it is not always necessary to replace the complete block. In many cases a suitable single replacement condenser will be available, and providing there is room for it, it can be utilised. Disconnect the faulty condenser (generally this will only involve unsoldering one lead since the block probably has a common negative or positive connection) and cut off the lead(s) close to the condenser casing. The new condenser should now be fixed in the chassis, preferably by a metal clip, or by binding it to the original unit with insulation tape. When connecting it up, do not forget to observe the correct polarity if it is of the electrolytic type.

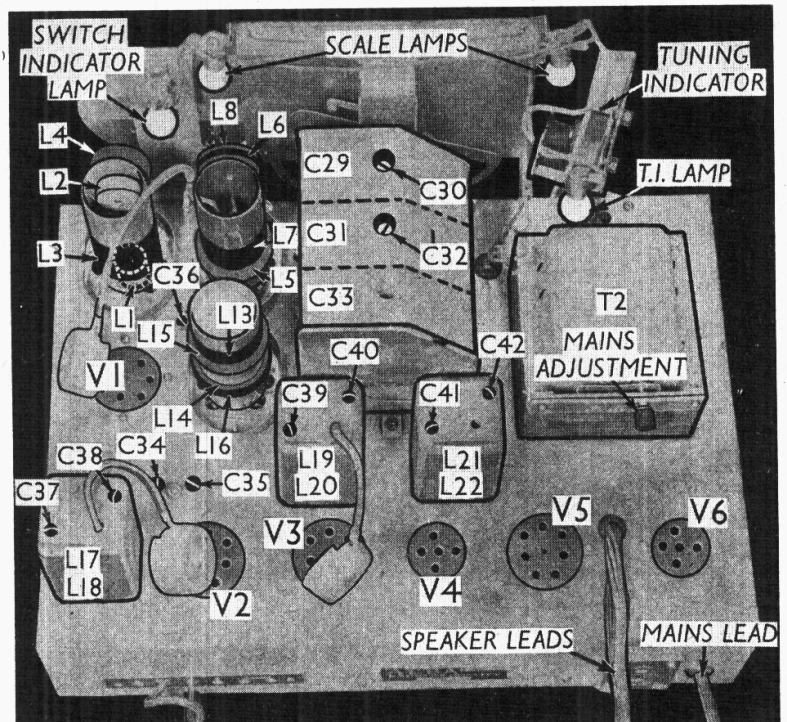

Plan view of the Alba 880 chassis. Three of the coil screens have been removed. Note that **L1** is inside the main former of one unit, near the chassis. The trimmers of **C33** (**C34** and **C35**) are adjusted through holes in the chassis deck, as is also **C36**.

For more information remember
www.savoy-hill.co.uk