

NUMBER FORTY-THREE
(VOLUME TWO)

'TRADER' SERVICE SHEETS

BUSH SB4 BATTERY SUPERHET

THE Bush SB4 is a 4-valve battery superhet, employing an octode frequency-changer and a double-diode triode valve for second detection, A.V.C. and L.F. amplification. The output valve is an "economy" pentode.

Several differences occur between early and recent chassis. This sheet deals mainly with the latest type, but the differences are fully explained under "General Notes."

CIRCUIT DESCRIPTION

Aerial input via coupling coils L1, L2 to inductively-coupled band-pass filter. Primary L3, L4 tuned by C17; secondary L6, L7 tuned by C20; coupling coils L8, L9. Image suppression by coil L5 and condenser C1. Local-distant switching by switch S1 and resistance R1 which shunts aerial-earth circuit.

First valve (V1, Mullard metallised FC2) is an octode operating as frequency-changer with electron coupling. Oscillator grid tuning coils L10, L11 tuned by C23; anode reaction coils, L12, L13; tracking by C6, C26 (M.W.) and C7, C27 (L.W.).

Second valve, a variable-mu H.F. pentode (V2, Mullard metallised VP2) operates as intermediate frequency amplifier with tuned-primary tuned-secondary transformer couplings L14, L15 and L16, L17.

Intermediate frequency 123 KC S.

Diode second detector forms part of double-diode triode (V3, Mullard

metallised TDD2). Second diode, fed from V2 anode by condenser C13, provides D.C. potential which is fed back through decoupling circuit R14, C3 as G.B. to frequency-changer and I.F. valves, giving automatic volume control. Delay voltage is obtained from drop along automatic G.B. resistance R18.

Audio-frequency output from rectifier diode is developed across manual volume control R8, tapped off, and passed by way of coupling condenser C11 and stopper resistance R9 to grid of V3 triode section.

Resistance-capacity coupling to output pentode (V4, Mullard PM22A). Fixed tone compensation by condenser C16 in anode circuit. Provision for connection of high-resistance external speaker across primary of T1, and for switching out internal speaker by plug and socket arrangement in secondary circuit of T1.

Grid-bias for V3 triode and V4 is obtained from voltage drop along resistances R17, R18 in common H.T. negative lead.

DISMANTLING THE SET

Removing Chassis.—Undo the clips holding the speaker and battery leads to the baffle and L.T. compartment. Remove control knobs (grub screws). When replacing, note that the large plain knob is the upper one, the small plain knob is at the left, while the small one marked "M.W., L.W." is at the right.

Remove the four screws and washers

holding chassis to base of cabinet. Chassis may now be withdrawn to the extent of the speaker leads, which will be sufficient for most repairs. To remove it entirely, unsolder the four speaker leads from the tags on the speaker transformer. These tags are marked, from left to right, 4, 3, 2, 1, and the corresponding coloured leads are red, black, black, yellow.

Removing Speaker.—The four nuts and washers holding the speaker chassis to the sub-baffle must be removed to free the speaker. It is not possible to remove the speaker on its baffle, since one of the baffle holding screws is covered by speaker.

COMPONENTS AND VALUES

Condensers		Values (μF)
C1	Part of image suppression circuit	0.01
C2	V1 pent. anode decoupling	0.1
C3	A.V.C. circuit decoupling	0.1
C4	V1 osc. grid resistance	0.0005
C5	V1 S.G.'s by-pass	0.1
C6	Osc. M.W. tracker, fixed	0.0022
C7	Osc. L.W. tracker, fixed	0.0011
C8	V1 osc. anode and V2 S.G. decoupling	0.1
C9	V2 anode decoupling	0.1
C10	I.F. by-pass	0.0001
C11	L.F. coupling to V3 triode	0.01
C12	V3 anode decoupling	0.1
C13	Coupling to V3 A.V.C. diode	0.00005
C14	L.F. coupling to V4	0.03
C15	H.T. reservoir	2.0
C16	Fixed tone compensator	0.003
C17	Band-pass primary tuning	—
C18	Band-pass pri. trimmer	0.000075
C19	Band-pass pri. L.W. trimmer	0.000075
C20	Band-pass secondary tuning	—
C21	Band-pass sec. trimmer	0.000075
C22	Band-pass sec. L.W. trimmer	0.000075
C23	Oscillator tuning	—
C24	Oscillator trimmer	0.000075
C25	Oscillator L.W. trimmer	0.000075
C26	Osc. M.W. tracker, pre-set	0.000075
C27	Osc. L.W. tracker, pre-set	0.000075
C28	1st I.F. trans. pri. tuning	0.00015
C29	1st I.F. trans. sec. tuning	0.00015
C30	2nd I.F. trans. pri. tuning	0.0003
C31	2nd I.F. trans. sec. tuning	0.0003

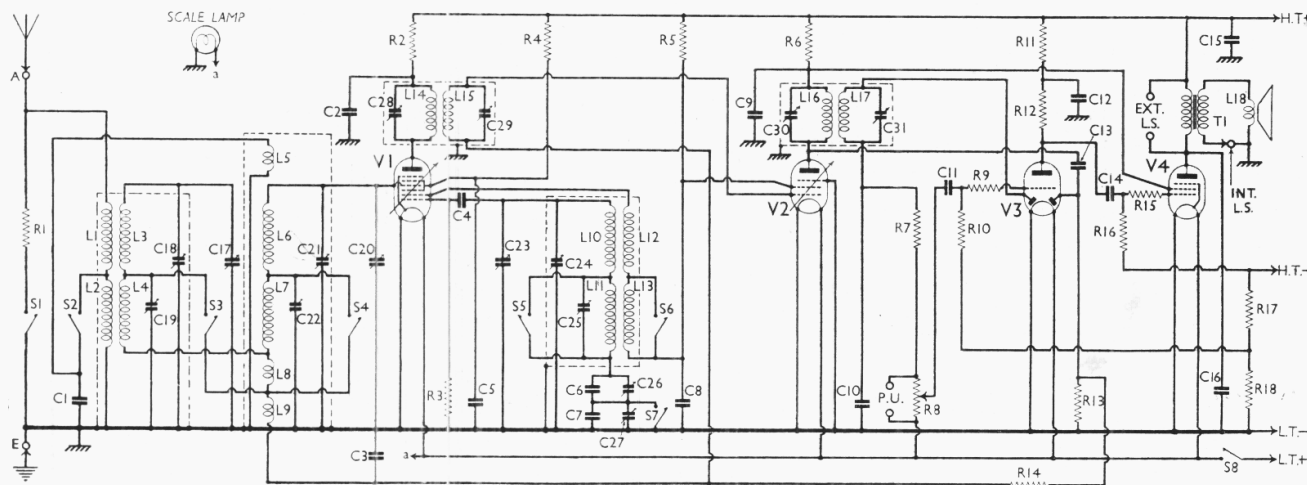

The circuit diagram of the latest model Bush SB4 battery superhet. In early models L5 is not employed, but a very small condenser, suitably connected, is substituted. In some models V1 is a heptode, in which case S6 is omitted. It will be seen that grid bias is automatic, no grid bias battery being used.

Manual

Resistances		Values (ohms)
R1	Local-dist. aerial-earth shunt	50
R2	V ₁ pent. anode decoupling	10,000
R3	V ₁ osc. grid resistance	70,000
R4	V ₁ S.G.'s H.T. feed	100,000
R5	V ₁ osc. anode and V ₂ S.G. H.T. feed	10,000
R6	V ₂ anode decoupling	10,000
R7	I.F. stopper	50,000
R8	Volume control (diode load)	500,000
R9	V ₃ triode grid I.F. stopper	500,000
R10	V ₃ triode grid resistance	5,000,000
R11	V ₃ triode anode decoupling	10,000
R12	V ₃ triode anode resistance	10,000
R13	V ₃ A.V.C. diode load	1,000,000
R14	A.V.C. circuit decoupling	1,000,000
R15	V ₄ grid H.F. stopper	100,000
R16	V ₄ grid resistance	500,000
R17	Automatic G.B. resistances	350
R18		250

Other Components		Values (ohms)
L1	Aerial coupling coils	1.5
L2		8.0
L3	Band-pass primary coils	3.0
L4		12.0
L5	Image suppression coil	Very low
L6	Band-pass secondary coils	3.0
L7		12.0
L8	Band-pass coupling coils	3.0
L9		0.5
L10	Oscillator tuning coils	4.0
L11		8.5
L12	Oscillator reaction coils	2.0
L13		2.5
L14	1st I.F. trans.	110.0
L15		110.0
L16	2nd I.F. trans.	60.0
L17		60.0
L18	Speaker speech coil	2.0
T1	Speaker input trans.	600.0
S1	Local-distant switch	0.25
S2-S7		Waveband switches, ganged
S8	Filament switch, ganged R8	

End view of the chassis, showing the condenser and resistance bank, and the I.F. transformers and trimmers, from which the screens have been removed. In early chassis, the I.F. assemblies were of a different pattern.

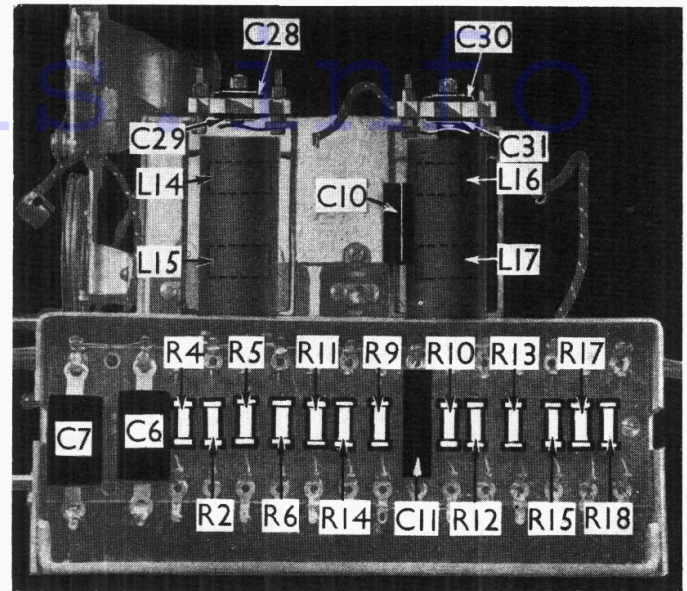

VALVE ANALYSIS

Valve	Anode Volts	Anode Current (mA)	Screen Volts	Screen Current (mA)
V ₁ FC2*	130	0.6	50	0.8
V ₂ VP2	105	2.15	120	1.4
V ₃ TDD2	100	1.9	—	—
V ₄ PM22A	140	2.1	80	0.45

*Osc. anode (G2) 120 V 0.45.

The voltage and current readings listed in the table are those given by the makers

for an average SB₄ chassis working with no aerial or earth connected, and with a new H.T. battery in use. All voltages were measured with a high resistance (1,000 Ω per V) meter, chassis being negative in each case. When measuring anode currents, the usual precautions should be taken, if necessary, to avoid instability.

GENERAL NOTES

Switches.—S1 is the Q.M.B. sensitivity switch, which is *closed* in the least sensitive position.

S2-S7 are the wavechange switches, which are in one assembly, and are indicated in the under-chassis view. S6 may be omitted in chassis employing a Corsor 210 PG in the first valve position. All the wavechange switches are *closed* in the M.W. position, and *open* in the L.W. position.

S8 is the Q.M.B. mains switch, ganged with the volume control R8.

Coils.—The band-pass and oscillator coils are in three screened units beneath the chassis. In our under-chassis view the screens have been removed, but are indicated by dotted lines. The screens are fitted by bayonet catches, and to remove the upper one (in our illustration) it will probably be necessary first to detach the volume control and mains switch unit, R8, S8.

The bottom unit (in our illustration) contains L1-L4, L3 and L4 are respectively single layer and slab windings on the tubular former, while L1 and L2 are inside, on a smaller former, and are indicated by dotted lines.

The middle unit contains L5-L9. L5 is an image suppressor coil, which does not occur in early chassis. In its place, a very small adjustable condenser is employed, which is fixed underneath the chassis between R3 and C5.

In chassis containing L5, it will be observed that there is a central nut and screw projecting through the top of the middle coil screen. This is an adjustable coupling device for L5, and must not be

(Continued overleaf)

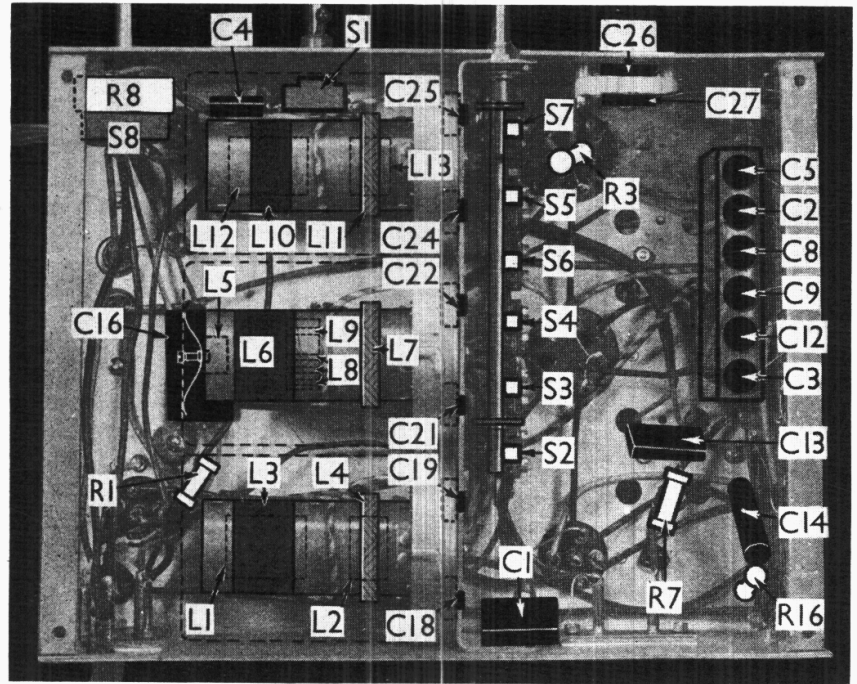

Under-chassis view. The switch assembly is clearly marked. The coil screens at the left have been removed, but are shown by broken lines. The coils inside the main formers are similarly indicated, as are the various trimmers at the bases of the coils.

BUSH MODEL S.B.4 (continued)

altered. The screen can be removed without disturbing it. L6 and L7 correspond with L3 and L4 in the bottom unit. L8 and L9 are wound in slots in a small former mounted transversely inside the main tubular former. L8 occupies three slots, and L9 one.

The top unit contains L10 and L11 wound on the main former, and L12 and L13 on a smaller former inside. C4, associated with this unit, is inside the screen.

The I.F. coils and trimmers in the latest type of chassis are of the type shown in our plan and end chassis views. They have tubular screens, with a double trimmer adjustment at the centre of the top of each screen. In each case the outer hexagonal nut adjusts the primary trimmer, while the central grub screw adjusts the secondary. The coils are mounted with the primary above the secondary in each case, and the second unit also contains the fixed condenser C10.

In early models a different form of I.F. transformer is employed, similar to those in the S.B.1 receiver. (Service Sheet No. 11, Vol. I.) In this type the coils are mounted similarly, but there are two separate trimmers reached through holes in the screen. In addition to C10, the second unit in the early models also contains C13 and R7, which therefore do not appear where indicated in our under-chassis view.

Chassis Divergencies.—Most of the differences between early and late chassis are explained under Switches and Coils above.

Some models may contain a Cossor 210 PG heptode in place of the Mullard FC2 octode in the V1 position. Where the heptode is employed, there will be found an extra resistance (not shown in our illustrations) connected between the top of L15 and the control grid of V2. Its value is 10,000 Ω. In addition, R3 becomes 40,000 Ω instead of 70,000 Ω, and S6 is omitted, so that L13 is not shorted on the M.W. band.

Scale Lamp.—This is an Osram M.E.S. type rated at 3.5 V, 0.15 A.

Plan view of the chassis. The I.F. transformers shown on the left are of the latest type, with concentrically adjusted trimmers. The tuning condenser trimmers are beneath the chassis.

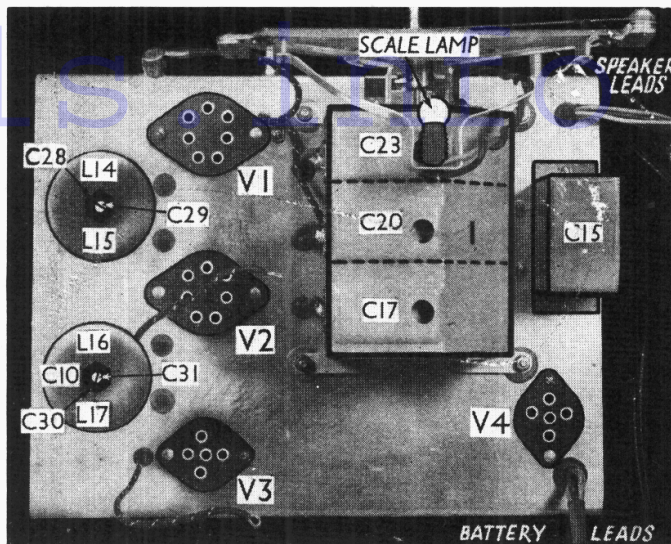

Condenser C1.—The value of this is 0.01 μ F in late chassis, but may be 0.0011 μ F in early models.

Condenser C16.—This is shown from plate of V4 to chassis in our diagram, but may be connected across the primary of T1 in some models.

Resistance R1.—This is covered with rubber tubing to prevent contact with the screen of the bottom coil unit.

Trimmers C18, C19, C21, C22, C24, C25.—These are situated at the bases of the three coil units, and are reached through holes in the partition between the switch unit and the coil units.

Trackers C26, C27.—These are in one unit, adjusted by a nut and grub screw at the front of the chassis. The hexagonal nut adjusts C26, and the grub screw C27.

Condenser Block C2, C3, C5, C8, C9, C12.—This contains six 0.1 μ F condensers, each having the earthed case as one connection.

Battery Cable.—The two L.T. leads are rubber covered, brown for LT+ and black for LT-. The two H.T. leads are rubber covered and braided, red for H.T. + (144 V) and black and green for H.T. -. Grid bias is automatic.

The L.T. battery is an Exide CZH2, and the H.T. a-Drydex 144V.

Valve Connections.—V1, the octode, has a 7-pin base and a top cap. Looking at the underside of the base, or of the valve-holder, and starting with the pin at the apex of the symmetrical figure (No. 1 in the B.V.A. code), this is the oscillator anode. Pin 2 (in a clockwise direction) is the oscillator grid; Pin 3, the screening grids; Pins 4 and 5, the filament; Pin 6, metallising; Pin 7, the anode; Top cap, pentode control grid. If a heptode is used, the connections are the same.

V2 connections are given in Sheet No. 11, Vol. I, p. 260.

V3 has a 5-pin base and top cap. The filament and triode anode connections are normal. The "grid" pin is the A.V.C. diode, the "cathode" pin is the detector diode, while the top cap is the triode control grid.

V4 has normal connections.

External Speaker.—This should be of the high impedance type (15,000 Ω), and should be connected to the sockets provided. The internal speaker may be cut out if desired by removing the single plug from the socket at the rear of the chassis, but only after the external speaker has been connected.

ROLA

the World's Finest Reproducers

Write to-day for the Rola Folder and the Rola Extension Speaker Broadsheet.

THE CORRECT EXTENSION SPEAKER FOR THE BUSH S.B.4 BATTERY SUPERHET IS

ROLA MODEL F.R.6—P.M.10

Price 39/6

This speaker can be fitted in a moment merely by connecting to the two extension speaker sockets at the rear of the set. Further, no complicated matching device is involved and the impedance of the speech coil of the above Rola speaker is exactly similar to that of the speaker in the set.

THE BRITISH ROLA CO., LTD., Minerva Road, Park Royal, N.W.10

Phone: Willesden 4322-3-4-5-6

Printed by Sanders Phillips & Co., Ltd., Chrysell Road, London, S.W.9

For more information remember
www.savoy-hill.co.uk