

'TRADER' SERVICE SHEETS

RECEIVER SERIES
(NUMBER ONE)

The PYE "P/B"

THE Pye P/B receiver is a self-contained battery-operated table model employing a super-heterodyne circuit with five thermionic valves and two dry contact metal rectifiers. An output stage of the Class B type is used, and is capable of delivering a maximum A.C. output of 1,250 mW.

CIRCUIT DESCRIPTION

Frame aerial (L1, L2 and C1) input to initial variable-mu S.G. H.F. amplifier (V1, Mazda metallised S215VM). Tuned-anode coupling (L3, L4 and C2) to combined oscillator and first detector, otherwise known as the frequency-changer (V2, Mazda metallised S215VM). Oscillator coupling coil (L8) in filament circuit. Tuned oscillator coil (L5, L6) in series with primary of first intermediate frequency transformer (T1) in plate circuit of V2. Single variable-mu S.G. I.F. amplifier (V3, Mazda metallised S215VM) coupled to second detector by T2. Both intermediates tuned to 114KC or 2631.5 metres. "Westector" second detector (W6) feeding via a special I.F. filter (L7, C18 and C19) into variable potentiometer (R5) forming manual volume control. R5 also serves as load across which A.V.C. control bias is developed. Voltage fed back to control grids of H.F. and I.F. amplifiers when it exceeds the delay voltage fixed by second "Westector" (W2) and potential divider consisting of R8, R9 and R10. Manual volume control (also operative on gramophone) coupled by intervalve transformer T5 to driver valve (V4, Mazda L2) which, in turn, is coupled to the Class B output stage (V5, Mazda PD220) by a special transformer (T4). V5 coupled to speech coil of speaker by T3. Compensating circuit (R6 and C21) across primary. Small fixed G.B. for Class B valve obtained from tapping on potential divider, R8, R9 and R10, associated with A.V.C. circuit.

DISMANTLING THE SET

Removing Chassis.—Disconnect and remove all batteries. Remove control knobs. There are no grub screws, and a direct pull is all that is required. If difficulty is experienced, loop pieces of string behind the knobs, and pull. To replace, see that V-shaped spring is in correct position in the knob, the latter being refitted with spring on the D section opposite the flat on the spindle. Remove valve screen (loosen 2 holding screws). Disconnect 3 frame aerial leads (loosen 3 screws F, F, F, Fig. 2). Unscrew battery switch from side of cabinet, and pull battery lead through hole in battery platform. Withdraw loud-speaker leads from sockets on chassis. Remove 4 slotted screws from base of cabinet. Withdraw chassis.

Removing battery platform and loud-speaker.—Remove four bolts and nuts (with lock-nuts) holding battery platform to cabinet side brackets. Withdraw platform and speaker.

Removing frame aerial.—Remove four wood screws holding it to front of cabinet. Withdraw carefully. When re-connecting to chassis, see that coloured leads go to correct terminals (Fig. 2.)

COMPONENTS AND VALUES

FUNCTION IN CIRCUIT	VALUE (μF)	
C 1	Frame aerial tuning	—
C 2	H.F. valve anode tuning	—
C 3	Oscillator tuning	—
C 4	H.F. valve anode circuit trimmer	—
C 5	Oscillator trimmer	—
C 6	H.F. and I.F. grids decoupling	0.1
C 7	H.F. screen-grid by-pass	0.1
C 8	H.F. anode circuit decoupling	0.1
C 9	H.F. anode circuit L.W. trimmer	—
C 10	H.F. to frequency-changer coupling	0.00002
C 11	Frequency-changer S.G. decoupling	0.1
C 12	I.F. transformer T1 tuning (Pri.)	—
C 13	I.F. transformer T1 tuning (Sec.)	—
C 14	Frequency-changer anode decoupling	0.1
C 15	Oscillator L.W. trimmer	—
C 16	I.F. transformer T2 tuning (Pri.)	—
C 17	I.F. transformer T2 tuning (Sec.)	—
C 18	I.F. filter condenser	0.0001
C 19	I.F. filter condenser	0.002
C 20	Intervalve transformer T5 coupling	0.25
C 21	Tone compensating capacity	0.0025

FUNCTION IN CIRCUIT	VALUE (Ohms)	
R 1	H.F. anode decoupling	2,000
R 2	Frequency-changer anode decoupling	2,000
R 3	Frequency-changer grid resistance	250,000
R 4	Part of A.V.C. circuit	100,000
R 5	Manual volume control	40,000
R 6	Tone compensating resistance	5,000
R 7	H.F. and I.F. grids decoupling	20,000
R 8*	A.V.C. delay voltage and Class B	118
R 9	G.B. potential divider	77
R 10†	G.B. potential divider	182
R 11†	Frequency-changer S.G. decoupling	65,000

* 77 Ω in early models. † 230 Ω in early models.
‡ Not in early models.

COMPONENT	VALUE (Ohms)	
L 1	Frame aerial, M.W.	18.3
L 2	Frame aerial, L.W. (inc. L1)	22.5
L 3	Anode coil, L.W. (inc. L4)	36.0
L 4	Anode coil, M.W.	4.0
L 5	Oscillator coil, M.W.	2.25
L 6	Oscillator coil, L.W. (inc. L5)	11.25
L 7	Filter choke	230.0
L 8	Oscillator filament coils, each	0.38
T 1	I.F. transformer: Primary	100.0
	Secondary	100.0
T 2	I.F. transformer: Primary	120.0
	Secondary	170.0
T 3	Output trans.: C.T. primary (each half)	285.0
	Output trans.: Secondary	23.0
T 4	Driver trans.: Primary	990.0
	C.T. secondary (each half)	155.0
T 5	Intervalve transformer: Primary	720.0
	Secondary	4,200.0
L.S.	Speaker speech coil	1.23

VALVE ANALYSIS

With new battery (130 V); H.T. +1 as instruction book (or see Special Notes overleaf); H.T. +2, 66 V; H.T. +3, 130 V; G.B.—, —4.5 V. All voltages below measured from anode or screen to chassis, with high resistance meter.

Valve	Anode Volts	Anode Curr. (mA)	Screen Volts	Screen Curr. (mA)
V1 (S215VM)	127	1.1	66	0.4
V2 (S215VM)	127	1.0	A5	0.4
			HT+1	
V3 (S215VM)	130	1.1	66	0.4
V4 (L2)	129	1.5	—	—
V5 (PD220)	129*	1.0†	—	—

* Each anode. † Total of both sections, meter in HT+3 lead, other valves removed.

(Continued overleaf)

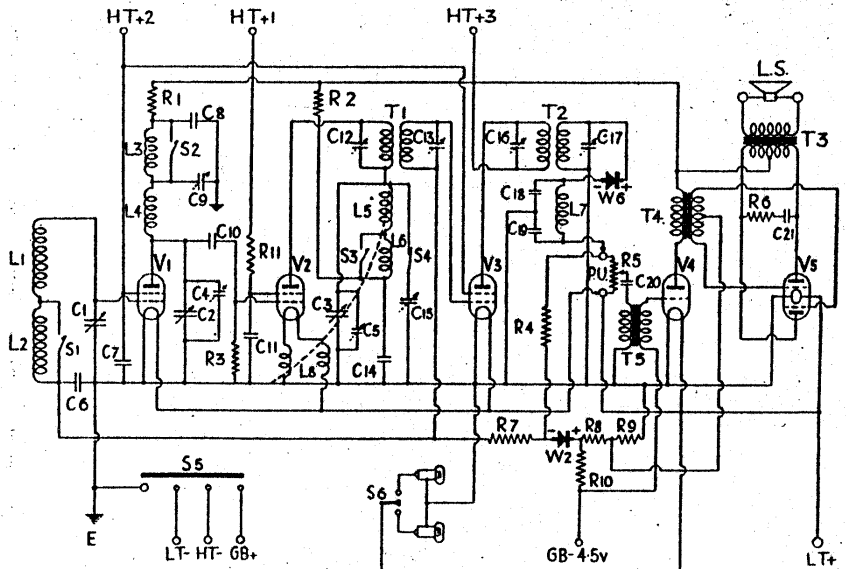

Fig. 1. The circuit of the Pye P/B.

For more information remember
www.savoy-hill.co.uk

The PYE P/B (contd.)

If tests on the set show wide discrepancies from values in valve table, check up valves first, and then all the components in each anode, screen or grid circuit. These are easily traced out from the circuit diagram (Fig. 1), identified in the chassis sketches (Figs. 2 and 3), and evaluated in the component tables.

SPECIAL NOTES

H.T. +1 Plug (green lead and plug). The position of this is fairly critical. It supplies screen voltage to frequency changer valve (V_2). If too low, valve will not function on L.W. band. If too high, general sensitivity is reduced. Correct voltage for valve supplied with set is given in instruction book. Otherwise, place H.T.+1 at least 3 V above lowest voltage that is consistent with stability at top of L.W. band. Keep battery cable away from frame aerial.

Resistance R_{11} (Figs. 1, 3) has now been fitted in series with H.T.+1 lead (65,000 Ω) to allow a better adjustment of voltage and to remove instability. Early receivers may not have R_{11} , which can be added if desired.

Most complaints so far received are due to the fact that sufficient care has not been taken with adjustment of H.T.+1.

Valve V_2 (frequency changer). It is important to select this valve carefully. Though a standard valve will work satisfactorily in this position, if one can be selected which allows H.T.+1 to be placed in a lower voltage before instability occurs, the set will be more efficient. It is advisable to try all the S215 VM valves supplied in turn in this position, and select the most suitable. This is normally done at the works, the boxes being numbered.

The Westectors. When servicing the set, care must be taken not to apply large voltages (for insulation or resistance tests) to W_2 and W_6 .

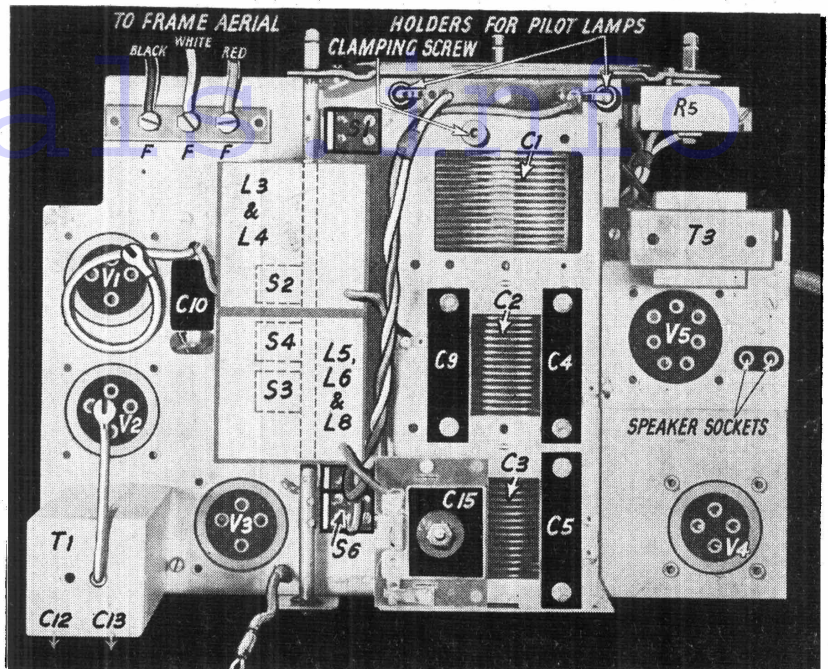

Fig. 2. Plan view of upper surface of chassis.

Pick-Up. This is connected to special plug, and plugged into sockets at rear of chassis. Special jack switch is thereby operated, switching off filaments of V_1 , V_2 and V_3 , and isolating pick-up and manual volume control from preceding circuits. If set is O.K. on gramophone, but not on radio, examine jack switch. Contacts should be closed when plug is out.

Pilot Lights. Replacement bulbs, 3.5V, 0.15 A. Bulb holder is clamped by one nut to top of gang condenser, at front of chassis. To remove, disconnect H.T.

battery, loosen nut, and withdraw holder. Holder acts as stop for condenser rotor, and when removed, a short may result if condenser is turned past maximum with H.T. connected. When replacing, clamp firmly.

Resistance R_6 . In the early models the 5,000 Ω resistance, marked R_6 on the circuit diagram, was mounted at the back of the volume control. Owing to the operation of this control, the tags were liable to be strained and fractured. With the more recent receivers it is mounted on the output transformer in the position shown in Fig. 3. When dealers have this trouble it is suggested that they re-mount in the new way.

Rubber Rings Round Valves. These are fitted to avoid any possibility of the metal coating of the frequency changer valve short circuiting to another. It is essential that the cathode of the frequency changer valve does not short to earth. If it does, the cathode coils will be short circuited.

Switch details. Wavechange (a) M.W. S_1 , S_2 , S_3 closed; S_4 open. (b) L.W. S_1 , S_2 , S_3 open; S_4 closed. Pilot light. S_6 switches on bulb behind appropriate dial aperture. Battery on-off. S_5 , situated on L.H. side of cabinet

Adjusting Tuned Circuits. The receiver has two tuned H.F. circuits, a tuned oscillator and four tuned I.F. circuits. These are accurately adjusted and sealed at the works. The seals should never be broken unless—(a) all voltages, currents and components have been checked and found O.K.; (b) the set is below standard for sensitivity or selectivity; and (c) accurate equipment is available for readjustment. Full instructions for readjustment are available from the makers, and are too long to be included here.

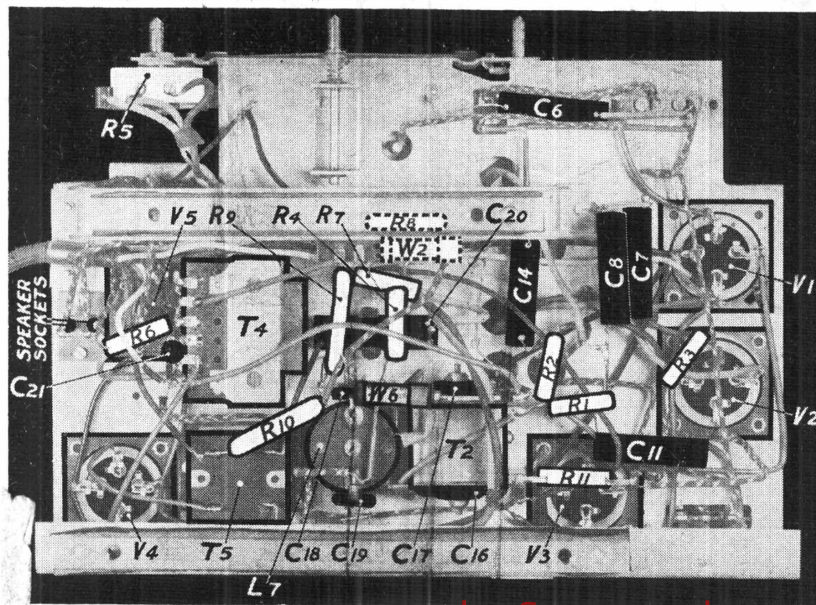

Fig. 3. Under-chassis view.

For more information remember